

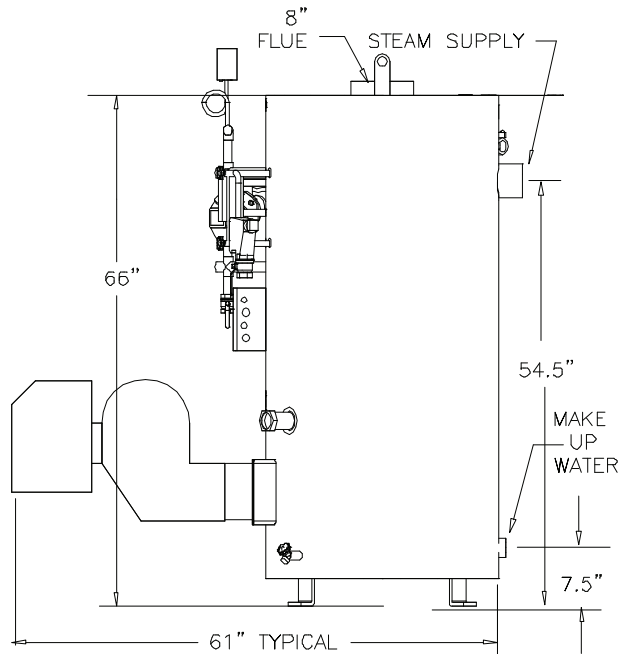

West Chicago, IL 60185
Phone: 630-562-2700
www.triadboiler.com

TRIAD BOILER SYSTEMS, INC. SERIES 900 STEAM BOILER

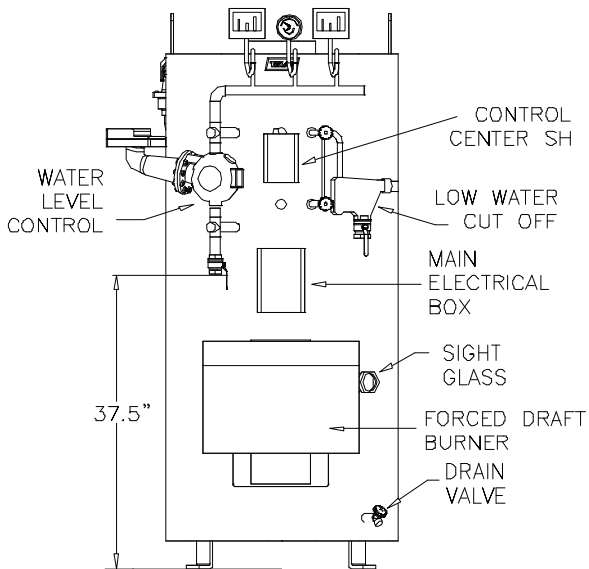
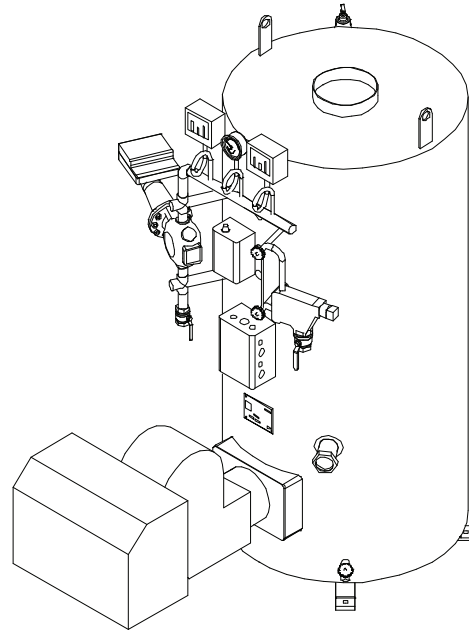
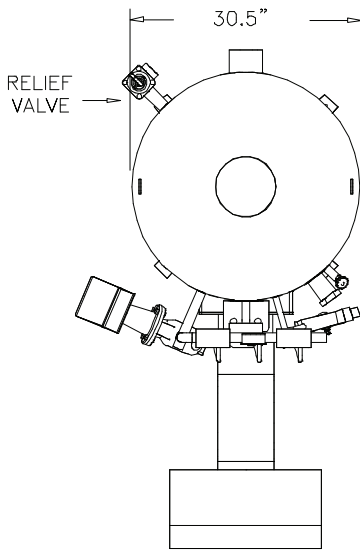

Note: Dimensions subject to change without notice.



TRIAD BOILER SYSTEMS, INC.
SERIES 900 STEAM (Model 900 GMS)

The Series 900 is a steel vertical firetube packaged boiler with a water-backed combustion chamber equipped with high-efficiency turbulators. Boilers come fully wired, and fit through a 34" doorway.

STANDARD EQUIPMENT:

- Forced Draft Burner (UL Listed)
- L404A-1354 Pressure Control
- L404c-1147 High Limit-Manual Reset
- Siphon Loops
- 150 Water Level Control
- 67 Low Water Cut-Off, Manual Reset
- Honeywell Control Relay
- Gauge Glass Assembly
- Pressure Gauge
- Operating Light
- 15 psi Relief Valve
- Vessel Pressure Rating of 125 PSI

OPTIONAL EQUIPMENT:

- Gas Fired (NG or Propane), Oil Fired, or Dual Fuel Burners
- UL, IRI, FM and CSD-1 Compliance
- Low-High, Low-High-Low and Modulating Gas Trains
- Sealed Combustion Air Intake
- Barometric Dampers
- UL Listed Boiler/Burner Package.

SPECIFICATIONS:

<i>Input BTU/Hr</i>	<i>Output BTU/Hr</i>	<i>Efficiency</i>	<i>HP Rating</i>	<i>Steam lbs./hr</i>
600,000	508,800	84.8%	15.2	524
700,000	589,400	84.2%	17.6	608
800,000	664,800	83.1%	19.8	685
900,000	746,100	82.9%	22.2	769
1,000,000	822,000	82.2%	24.5	847

Note: Typical for Natural Gas. - Oil or LP burner data may vary.

APPLICATIONS:

Space Heating up to 15psi

CLEARANCES & CONNECTIONS:

6" between boilers (36" center to center), 8" from front of burner, steam outlet diameter - 4" threaded, makeup water – 2.5".

CONTROL:

The Series 900 can operate on its own controls, but a TRIAD microprocessor control panel is recommended for sequencing more than two boilers to minimize run-time and fuel usage.

FLUE: Category 1 when properly applied.

POWER: 120V, 60Hz, Single Phase, fused for 30 amps. Min / Max gas pressure, typically 5.6" / 14" WC

WEIGHT/VOLUME:

- Shipping Weight – 1,300 lbs.
- Operating Weight - 1,885lbs.
- Volume – 55 gallons

ALL BURNER EQUIPMENT UL APPROVED

TRIAD BOILER REPRESENTATIVE:

TRIAD Boiler Systems, Inc.

West Chicago, IL 60185
 Phone: 630-562-2700
 Fax: 630-562-2800
 Web: www.com.com