

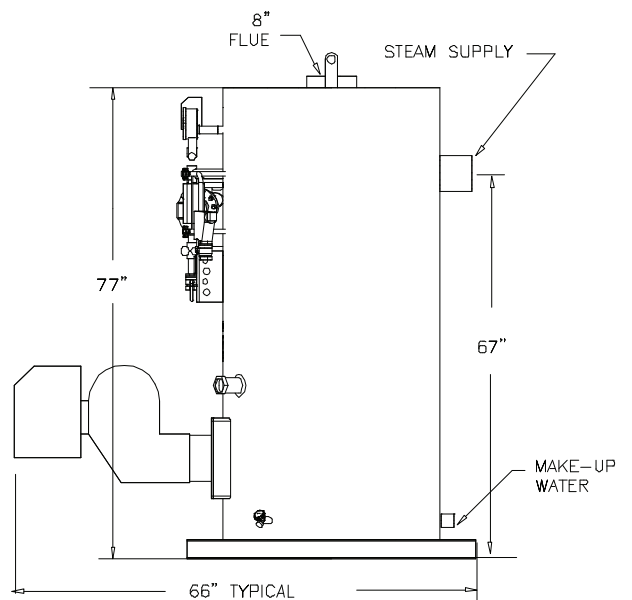

West Chicago, IL 60185
Phone: 630-562-2700
www.triadboiler.com

TRIAD BOILER SYSTEMS, INC. SERIES 1600 STEAM BOILER

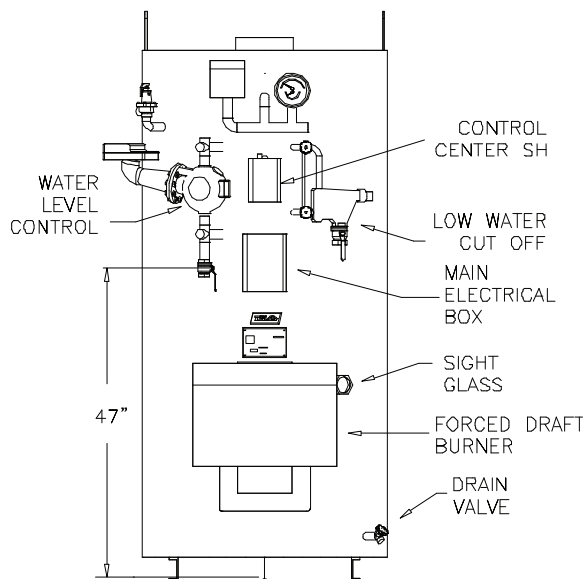
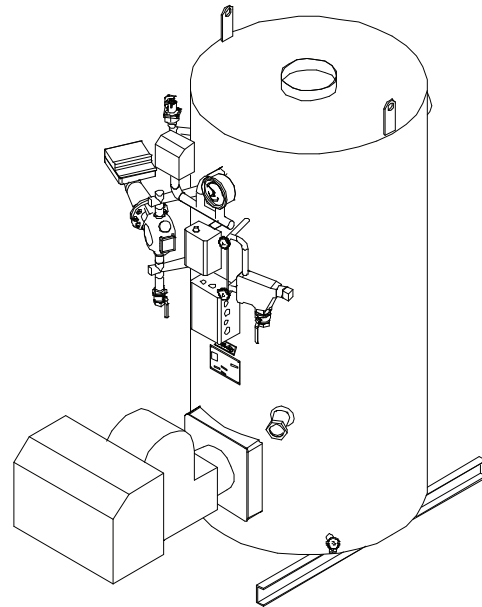
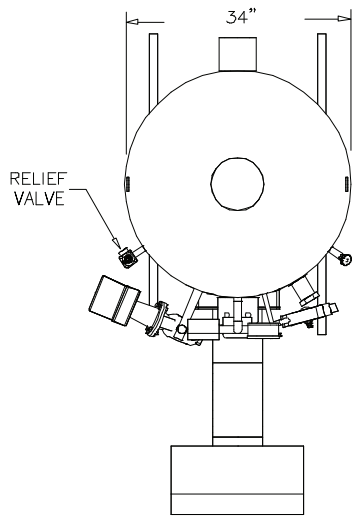

Note: Dimensions subject to change without notice.



TRIAD BOILER SYSTEMS, INC.
SERIES 1600 STEAM (Model 1600 GMS)

The Series 1600 is a steel, vertical firetube packaged boiler with a water-backed combustion chamber equipped with high-efficiency turbulators. Boilers come fully wired, and fit through a 34" doorway.

STANDARD EQUIPMENT:

- Low/High/Off Power Burner (UL Listed)
- P7810C Solid State Pressure Control, Manual Reset
- 150 Water Level Control
- 67 Low Water Cut-Off, Manual Reset
- Honeywell Control Relay
- Gauge Glass Assembly
- Pressure Gauge
- Operating Light
- 15 psi Relief Valve
- Lifting Lugs
- Vessel Pressure Rating of 125 PSI
- UL Listed Boiler/Burner Package.

OPTIONAL EQUIPMENT:

- Gas Fired (NG or Propane), Oil Fired, or Dual Fuel Burners
- UL, IRI, FM and CSD-1 Compliance
- Low/High/Low and Modulating Gas Trains
- Sealed Combustion Air Intake
- Barometric Dampers

SPECIFICATIONS:

<i>Input BTU/Hr</i>	<i>Output BTU/Hr</i>	<i>Efficiency</i>	<i>HP Rating</i>	<i>Steam lbs./hr</i>
1,200,000	996,000	83.0%	29.8	1,027
1,300,000	1,079,000	83.0%	32.3	1,112
1,400,000	1,162,000	83.0%	34.7	1,198
1,600,000	1,328,000	83.0%	39.7	1,369
1,700,000	1,411,000	83.0%	42.2	1,454

Note: Typical for Natural Gas. - Oil or LP burner data may vary.

APPLICATIONS:

Space Heating and Process up to 15psi

CLEARANCES & CONNECTION SIZES:

10" between boilers, 10" from front of burner, 6" steam outlet, 3" makeup water.

CONTROL:

The Series 1600 can operate on its own controls, but a TRIAD microprocessor control panel is recommended for sequencing more than two boilers to minimize run-time and fuel usage.

FLUE: Category I when applied appropriately.

POWER: 120V, 60Hz, Single Phase, fused for 30 amps. (208/230/460 – 3 phase optional). Min / Max gas pressure, typically 4.9" / 14" WC

WEIGHT/VOLUME:

- Shipping Weight – 1,750 lbs.
- Operating Weight - 2,575 lbs.
- Volume – 90 gallons

TRIAD BOILER REPRESENTATIVE:

TRIAD Boiler Systems, Inc.

- West Chicago, IL 60185
- Phone: 630-562-2700
- Fax: 630-562-2800
- Web: www.com.com