

V11TM Series

Commercial Hydronic Heat Pressure Fired,
Wet Base, Oil, Gas or Combination



■ Heating Capacities
667 to 4551 MBH Output



V11 Series - Hot Water or Steam Boiler

Maximum Allowable Working Pressure: 80 PSI-Water; 15 PSI-Steam

Your Commercial Heating Solution

Available in twenty sizes with gross output ratings from 667 to 4551 MBH, the V11 Series is commonly used in schools, hospitals and other large commercial applications where comfort and reliability are important. The product meets the energy efficiency requirements of ASHRAE 90.1 with combustion efficiencies up to 85%.

Cast iron construction, ease of assembly, two venting options, and stringent testing methods make the V11 Series boiler by Burnham Commercial your heating solution.

Cast Iron Dependability

Cast iron has the unique ability to absorb and transfer heat quickly and efficiently while providing unmatched durability. That's why the cast iron design of the V11 is the best choice for long lasting, trouble-free operation in commercial and industrial applications.



- **Manufactured with Quality**

Burnham Holdings owns and operates a state-of-the-art foundry, in Zanesville, OH, ensuring quality and availability for all V11 castings as well as those for all other Burnham Commercial boilers.

- **Cast Iron Nipple Difference**

While gaskets used by other manufacturers can break down from oils and contaminants, the V11's cast iron nipples remain unaffected, ensuring long life and eliminating costly repairs.

The V11 section assembly includes precision machined cast iron nipples that expand and contract along with the sections they join providing integrity to the entire assembly. Cast iron nipples resist boiler flue gases and petroleum based chemicals, including corrosion inhibitors, pump lubricants and antifreeze.



Installation & Service Flexibility

The cast iron sectional design of the V11 boiler makes it easy to maneuver through doorways and into the boiler room. In addition to being shipped as loose sections, the boiler is available with factory-assembled sections or as a completely packaged and fire-tested unit.

- **Hassle-free Section Assembly**

V11 boiler sections have reinforced lugs that are used to assemble the sections with individual draw rods resulting in fast, strain-free assembly.



The sections can be assembled using two common tools—a 3/4" drive ratchet with a 1 1/4" deep socket and wrench.

The sections are surface ground to ensure smooth surface mating. An elastic sealant and fiberglass rope are used on all section joints for a completely sealed and pressure-tight assembly.

- **Extensive Testing Methods**

Each boiler section is hydrostatically tested at two and one half times the rated working pressure at the foundry. Factory assembled sections are tested at one and one half times the rated working pressure.

- **Rear or Top Venting**

As a forced draft boiler, the V11 provides optimum draft for controlled efficiency, eliminating the need for high chimneys or induced draft fans. A unique feature of the V11 boiler is it can be vented from the rear or the top. This enables easy chimney or side-wall venting for maximum installation flexibility.

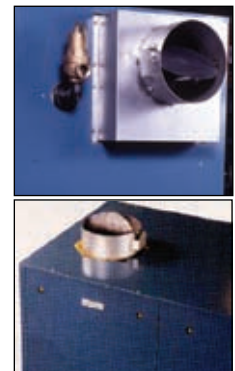

Top outlet venting saves floor space and reduces installation time and materials. A plugged tapping is provided to take flue outlet pressure readings.

The "Smart" Choice

Specifying a heating system, preparing boiler room layouts and creating sales submittals are all made easy with Burnham Commercial's SmartDesign CD. Engineering and sales tools are all in one place along with AutoCAD drawings that are at a 1" to 1" scale and can be copied and pasted into an existing boiler



room layout. Consult your local Burnham Commercial sales representative or visit our new website www.burnhamcommercialcastiron.com for details.

Commitment to Quality

Burnham Commercial, "America's Boiler Company," has earned a reputation for quality and dependability. Built for a variety of applications, the V11 Series is right for your next job.

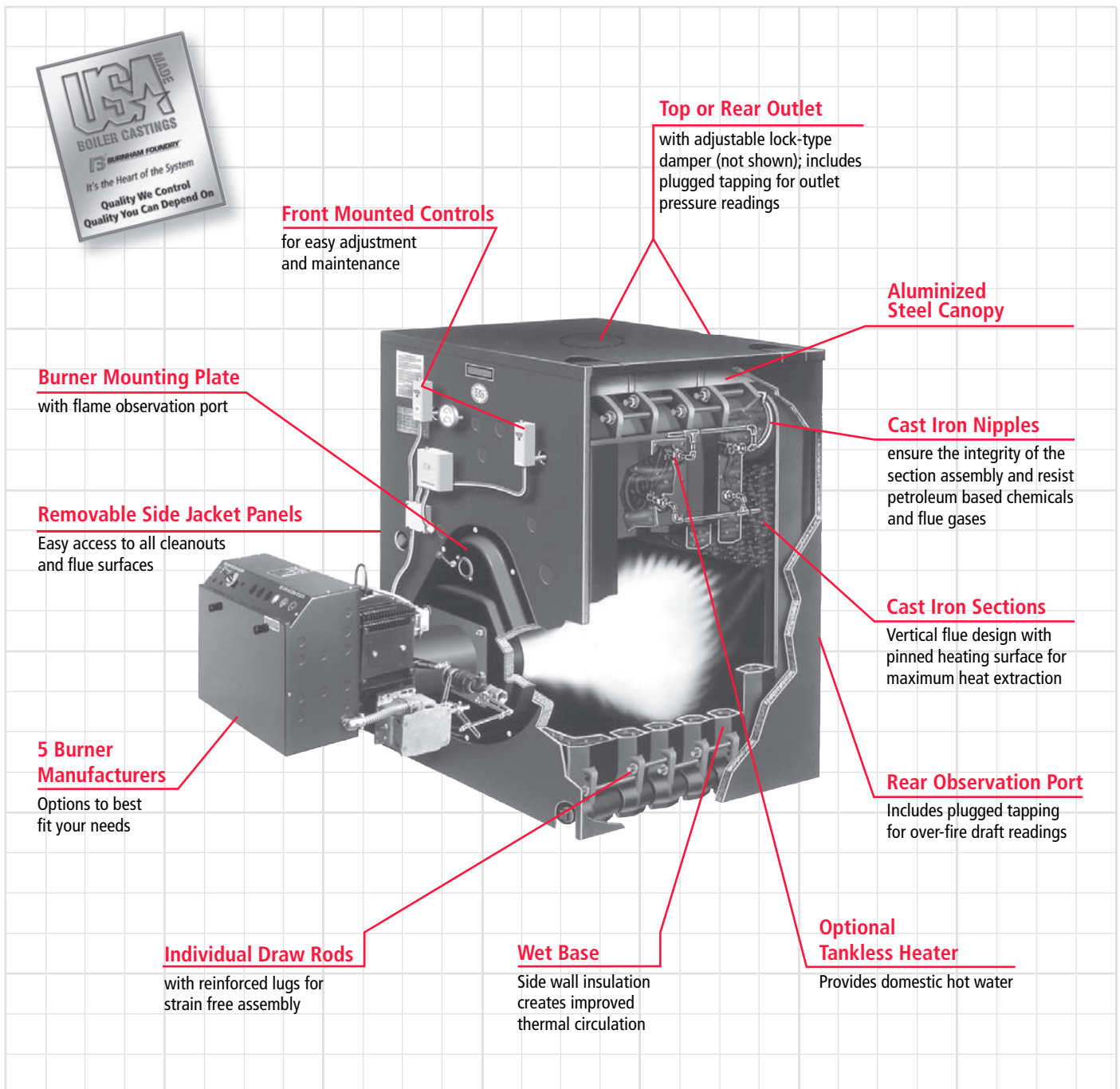

V11 SERIES DIMENSIONS (in inches)

BOILER MODEL	NUMBER OF SECTIONS	'A'	'B'	'C'	'D'	'E'	'F'	'G'	'H'	'J'	'K'	'L'	BURNER DIMENSION - 'M' *						APPROX. WEIGHT OF SECTION (Assembly Only)	
													BECKETT		CARLIN	GORDON-PIATT		WEBSTER		
													CF	CG		R	CR	JR**		JB
V1104	4	26-5/8	18-7/8	—	—	—	—	—	13-13/16	55	8	1	24-3/4	21-3/4	—	27-1/2	30	20-1/4	25	1833
V1105	5	32-3/4	25	—	—	—	—	—	19-15/16	55	8	2	24-3/4	21-3/4	19-3/4	27-1/2	30	20-1/4	25	2226
V1106	6	38-7/8	31-1/8	31-1/8	—	—	—	—	26-1/16	55	8	2	24-3/4	28-3/4	19-3/4	27-1/2	35	23-3/4	25	2618
V1107	7	45	37-1/4	37-1/4	—	—	—	—	32-3/16	54	10	3	24-1/4	29-1/4	20-1/2	30	35	23-3/4	25	3010
V1108	8	51-1/8	43-3/8	43-3/8	—	—	—	—	38-5/16	54	10	3	24-1/4	29-1/4	20-1/2	30	35	23-3/4	25	3403
V1109	9	57-1/4	49-1/2	49-1/2	—	—	—	—	44-7/16	54	10	4	24-1/4	29-1/4	20-1/2	30	35	—	25	3795
V1110	10	63-3/8	55-5/8	24-3/4	30-7/8	—	—	—	50-9/16	53	12	4	24-1/4	29-1/4	25-5/8	30	35	—	25	4188
V1111	11	69-1/2	61-3/4	37	24-3/4	—	—	—	56-11/16	53	12	4	24-1/4	29-5/8	25-5/8	30	40	—	29	4580
V1112	12	75-5/8	67-7/8	37	30-7/8	—	—	—	56-5/8	53	12	5	25-3/4	29-5/8	25-5/8	30	40	—	29	4972
V1113	13	81-3/4	74	37	37	—	—	—	53-5/16	53	12	5	25-3/4	29-5/8	26-1/8	30	40	—	29	5365
V1114	14	87-7/8	80-1/8	24-3/4	24-1/2	30-7/8	—	—	53-5/16	52	14	5	27	29-5/8	26-1/8	30	40	—	29	5757
V1115	15	94	86-1/4	24-3/4	24-1/2	37	—	—	53-5/16	52	14	6	27	29-5/8	26-1/8	30	40	—	29	6150
V1116	16	100-1/8	92-3/8	30-7/8	36-3/4	24-3/4	—	—	53-5/16	52	14	6	26	29-5/8	26-1/8	30	40	—	29	6542
V1117	17	106-1/4	98-1/2	30-7/8	36-3/4	30-7/8	—	—	53-5/16	52	14	6	—	29-5/8	26-1/8	30	40	—	29	6934
V1118	18	112-3/8	104-5/8	30-7/8	24-1/2	24-1/2	24-3/4	—	53-5/16	51	16	7	—	29-5/8	—	31-3/4	40	—	29	7327
V1119	19	118-1/2	110-3/4	30-7/8	24-1/2	24-1/2	30-7/8	—	53-5/16	51	16	7	—	29-5/8	—	31-3/4	40	—	29	7719
V1120	20	124-5/8	116-7/8	30-7/8	24-1/2	36-3/4	24-3/4	—	53-5/16	51	16	8	—	—	—	31-3/4	40	—	29	8112
V1121	21	130-3/4	123	30-7/8	24-1/2	36-3/4	30-7/8	—	53-5/16	51	16	8	—	—	—	31-3/4	40	—	29	8504
V1122	22	136-7/8	129-1/8	30-7/8	24-1/2	24-1/2	24-3/4	—	53-5/16	50	18	9	—	—	—	31-3/4	46	—	29	8896
V1123	23	143	135-1/4	30-7/8	24-1/2	24-1/2	30-7/8	—	53-5/16	50	18	9	—	—	—	31-3/4	46	—	29	9289

*Burner control panel configuration may change this dimension.
 **Add 10 inches when equipped with optional control panel

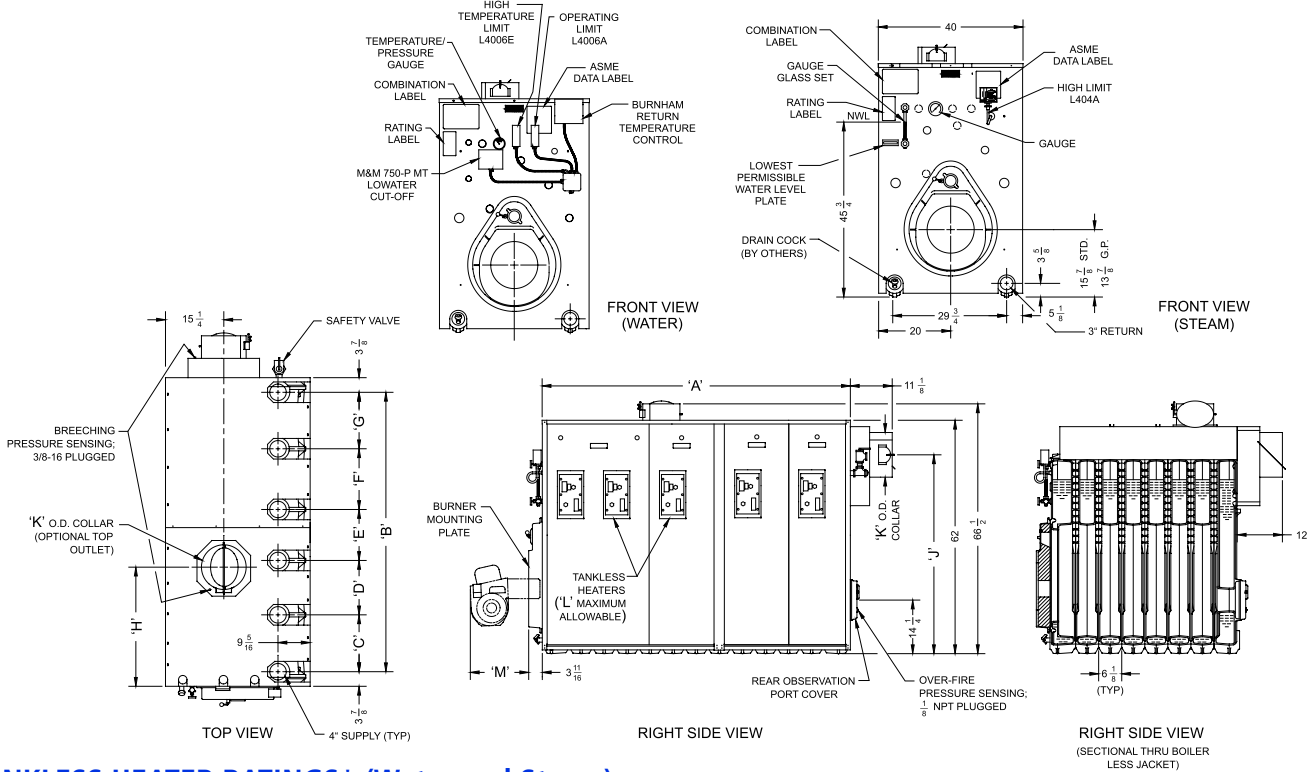

TANKLESS HEATER RATINGS* (Water and Steam)

BOILER MODEL	NUMBER OF V11-2 TANKLESS HEATERS INSTALLED								
	1	2	3	4	5	6	7	8	9
V1104	8								
V1105	8	16							
V1106	8	16							
V1107	8	16	24						
V1108	8	16	24						
V1109	8	16	24	32					
V1110	8	16	24	32					
V1111	8	16	24	32					
V1112	8	16	24	32	40				
V1113	8	16	24	32	40				
V1114	8	16	24	32	40				
V1115	8	16	24	32	40	48			
V1116	8	16	24	32	40	48			
V1117	8	16	24	32	40	48			
V1118	8	16	24	32	40	48	56		
V1119	8	16	24	32	40	48	56		
V1120	8	16	24	32	40	48	56	64	
V1121	8	16	24	32	40	48	56	64	
V1122	8	16	24	32	40	48	56	64	72
V1123	8	16	24	32	40	48	56	64	72

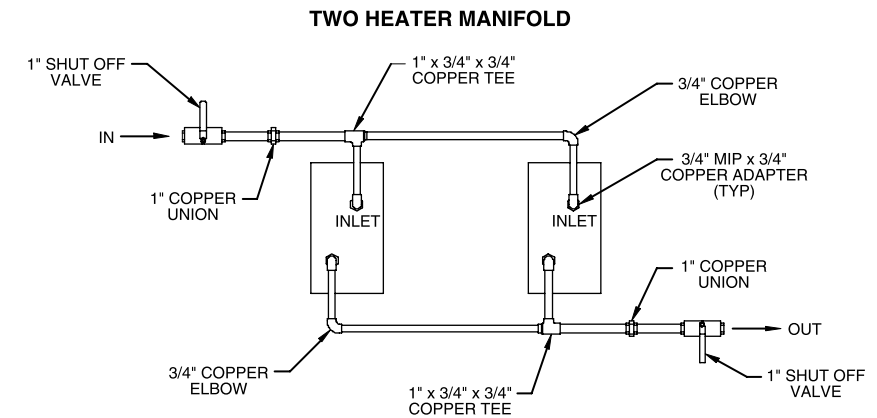

* Ratings are given in gallons per minute continuous draw of water heated from 40°F to 140°F with 200°F boiler water.

PACKAGED BOILER INFORMATION

In addition to being shipped as individual sections, the V11 boiler is available with factory-assembled sections or as a completely packaged unit. The packaged unit is fastened to a steel skid to facilitate lifting with a fork truck or crane. The skid can serve as the boiler foundation, replacing the need for a concrete pad. A factory fire-test is also available on all packaged units.

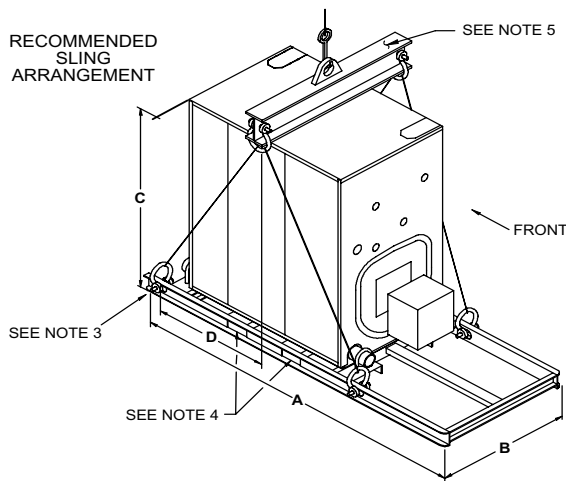

1. Do not tilt. Exercise caution when lifting to avoid damage.
2. This boiler can be lifted by fork truck of appropriate capacity. Do not truck from front.
3. When lifting from rear, forks must extend beyond center of gravity and second skid cross bar.
4. When lifting from side, forks must extend to opposite skid rail and straddle center of gravity.
5. Cable spreader is to prevent jacket damage. Spreader width should equal B (width of skid) + 12". Adjust cable lengths to lift at approximate center of gravity per chart.

BOILER MODEL	NUMBER OF SECTIONS	LENGTH A	WIDTH B*	HEIGHT C**	APPROX. CENTER OF GRAVITY D***	APPROX. SHIPPING WEIGHT LBS.***
V1104	4	71-1/4	48	68	22	2,438
V1105	5	77-1/2	48	68	25-1/4	2,899
V1106	6	89-1/2	48	68	28-1/4	3,360
V1107	7	95-1/2	48	68	31-3/4	3,806
V1108	8	101-3/4	48	68	35	4,254
V1109	9	108	48	68	38-1/2	4,689
V1110	10	114	48	68	41-1/2	5,129
V1111	11	120	48	68	44-1/2	5,597
V1112	12	130-1/4	48	68	47-1/2	6,029
V1113	13	136-1/2	48	68	50-3/4	6,537
V1114	14	142-1/2	48	68	53-3/4	6,880
V1115	15	148-1/2	48	68	56-3/4	7,408
V1116	16	154-3/4	48-1/2	70	59-3/4	7,835
V1117	17	161	48-1/2	70	63	8,265
V1118	18	167	48-1/2	70	67	8,691
V1119	19	173	48-1/2	70	70	9,140
V1120	20	179-1/4	48-1/2	70	73	9,567
V1121	21	185-1/2	48-1/2	70	76-1/4	10,005
V1122	22	197-1/2	48-1/2	70	79-1/4	10,429
V1123	23	203-1/2	48-1/2	70	82-1/4	10,859

- * Width can vary with gas train configuration.
 ** Add 6-1/2" to dimension C when equipped with optional top outlet.
 *** Varies slightly with burner and gas train configuration and with or without RTC.

BURNER MOUNTING PLATES AND ADAPTER PLATES

POWER FLAME ('CR' SERIES) BURNER ADAPTER PLATE

BOILER MODEL	PART NO.	I.D. NO.	'A' DIA.	'B' DIA.
V-1104 thru 1105	602263401	40	7-1/2	10-1/4
V-1106 thru 1110	602263411	41	9	12
V-1111 thru 11121	602263421	42	10-3/8	14-1/8
V-1122 and 1123	Adapter furnished with burner			

POWER FLAME ('JR' SERIES) BURNER ADAPTER PLATE

BOILER MODEL	PART NO.	I.D. NO.	'A' DIA.	'B' DIA.
V-1104 and 1105	602263451	45	6-3/8	10-1/4
V-1106 thru 1108	602263461	46	6-3/8	11-11/6

GORDON-PIATT ('R' SERIES) BURNER

V-1104 thru 1123	Adapter plate is furnished with burner loose in burner carton			
------------------	---	--	--	--

WEBSTER ('JB' SERIES) BURNER ADAPTER PLATE

BOILER MODEL	PART NO.	I.D. NO.	'A' DIA.	'B' DIA.
V-1104 thru 1110	602263601	60	7-5/8	10-3/4
V-1111 thru 1123	602263611	61	9-5/8	12-3/4

BECKETT ('CF' SERIES) BURNER ADAPTER PLATE

BOILER MODEL	PART NO.	I.D. NO.	'A' DIA.	'B' DIA.
V-1104 thru 1109	602263001	00	6-3/4	10
V-1112 and 1113				
V-1110, 1111, 1114 and 1115	602263011	01	8-1/4	10
V-1116				
V-1116	602263021	02	10-1/4	11

BECKETT ('CG' SERIES) BURNER ADAPTER PLATE

BOILER MODEL	PART NO.	I.D. NO.	'A' DIA.	'B' DIA.
V-1104 and 1105	602263031	03	5	10
V-1106	602263041	04	6	10
V-1107 thru 1110	602263071	07	7-1/4	10
V-1111 thru 1119	602263081	08	8-1/8	11

CARLIN ('CRD' & 'FFD' SERIES) BURNER ADAPTER PLATE

BOILER MODEL	PART NO.	I.D. NO.	'A' DIA.	'B' DIA.
V-1105 thru 1109	602263301	30	6-1/8	10
V-1110 thru 1113	602263311	31	9	10
V-1114 thru 1117	602263321	32	10-1/4	11

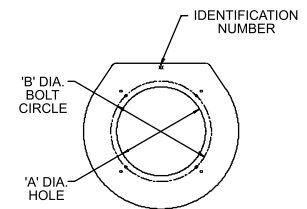

STANDARD BURNER ADAPTER PLATE

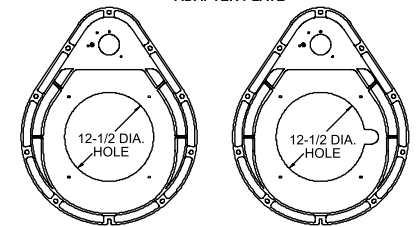

STANDARD

GORDON-PIATT

CAST IRON BURNER MOUNTING PLATE
PART NUMBER 60226011

CAST IRON BURNER MOUNTING PLATE
PART NUMBER 60226021

Notes:

1. A mounting plate and adapter plate are needed for each unit.
2. All PF CR3 and CR4 burners have diamond shaped adapter plate.

CONTROL TAPPINGS

TAPPING LOCATION	SIZE (IN.)	STEAM BOILER	WATER BOILER
A	4	Supply	Supply
B	3	Return	Return
C	3	Safety Valve	Relief Valve
D	1-1/2	Crown Inspection/Washout (Special Order Only)	Crown Inspection/Washout (Special Order Only)
E1	1	Float L.W.C.O.	Float L.W.C.O.
E2	1	Float L.W.C.O.	Float L.W.C.O.
F	1	Auxiliary Float L.W.C.O. (Special Order Only)	—
G	3/4	—	Probe L.W.C.O.
H	3/4	—	Auxiliary Probe L.W.C.O. (Special Order Only)
J	3/4	Firing Rate Pressure Control	Firing Rate Temperature Control
K1	3/4	Operating Pressure Limit Control	Operating Temperature Limit Control
K2	3/4	High Pressure Limit Control/Manual Reset	High Temperature Limit Control/Manual Reset
L	1/2	Gauge Glass	Not Used - Plug
M	1/2	Steam Gauge (Bush to 1/4")	Temperature/Pressure Gauge
N	3/4	—	Auxiliary Tapping (Special Order Only)

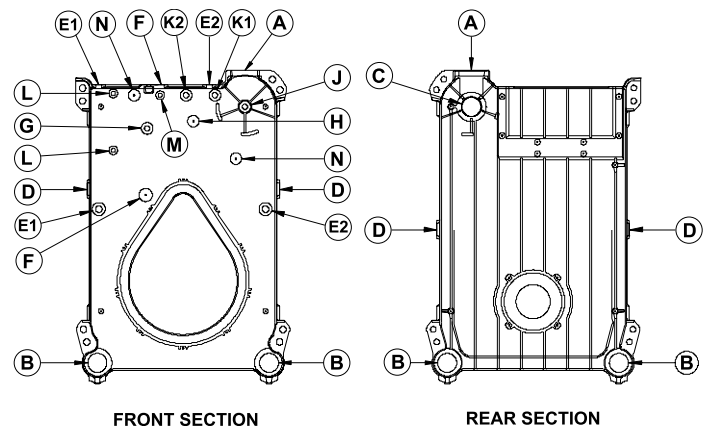

FRONT SECTION

REAR SECTION

V11 Series Minimum Piping Recommendations — Water Boiler

System Design

Hydronic heating system designs include system piping, near boiler piping, water/steam circulation, controls and accessories. Our recommendations cover the near boiler piping. They are designed to facilitate the installation of the V11 into existing and new heating systems.

System Piping Factors

Many hot water heating systems involve the use of system zoning with zone valves or pumps and may include some form of mixing device. Use of these components can effect flow through the boiler and return water temperatures. These factors must be considered for proper system design.

Multiple zone heating systems, as shown in illustration 1, can produce varying flow rates and water temperatures through the boiler.

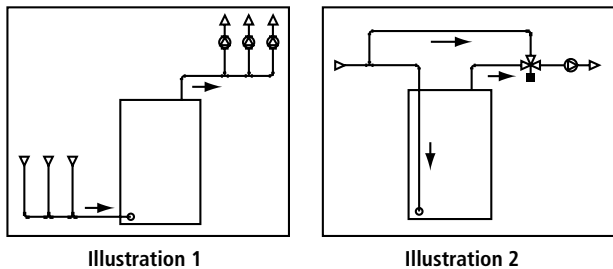

The piping arrangement shown in illustration 2 shows how tempering valves have typically been used to provide system blending: cool return water is mixed with hot supply water through a mixing valve. This tempers the water temperature to the system but can subject the boiler to varied flow and cool return water temperatures.

Recommended Near Boiler Piping

Burnham Commercial's near boiler piping recommendations are aimed at applying the V11 boiler to various system designs.

The three water boiler recommendations are each based on system operating characteristics. The minimum operating criteria are a maximum temperature difference of 40° F under all operating conditions and no less than 135° F return water temperature for prolonged periods of time.

- **Recommendation 1** - is used when the load is constant and not varied due to mixing or multiple zones.
- **Recommendation 2** - is a primary-secondary piping method that maintains a constant flow through the boiler

by using a secondary boiler circulator. This arrangement isolates the boiler from flow variations but does not safeguard against cold return water temperatures.

- **Recommendation 3** - is used when the return water temperature does go below 135°F for prolonged periods of time. This is also primary-secondary piping, but includes the addition of a 3-way valve, return water sensor and boiler-mounted RTC Return Temperature Control.

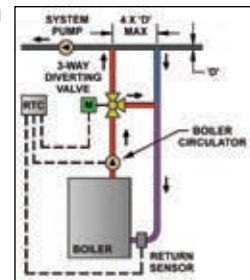

RTC Return Temperature Control

The concept of boiler protection has existed for many years. The Burnham Commercial RTC Return Temperature Control* simplifies the process and provides an economical and effective means of protecting the boiler from thermal shock and sustained condensing operation.

One RTC is required per boiler and can be incorporated into most hydronic hot water applications with minimal modifications to the system design and operation.



V11 pictured with RTC.

*Please see RTC specifications sheet for complete details and proper circulator sizing.

Outdoor Reset Option

The RTC outdoor reset option for single boiler applications provides additional energy savings by modulating system water temperature to closely match the building load requirements.

V11 Series Minimum Piping Recommendations — Water Boiler

Recommendation 1 — Use when:

- system return water is not less than 135° F for prolonged periods of time
- system flow does not impact flow through the boiler

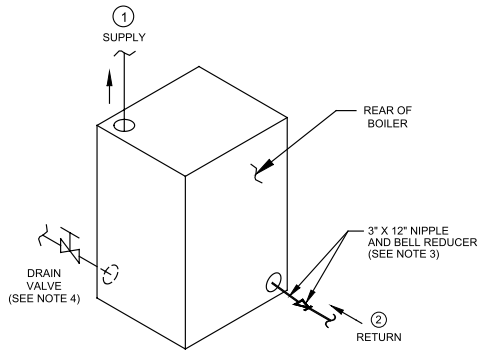

V1104 THRU V1108 (W/20°F DROP)
V1104 THRU V1117 (W/40°F DROP)

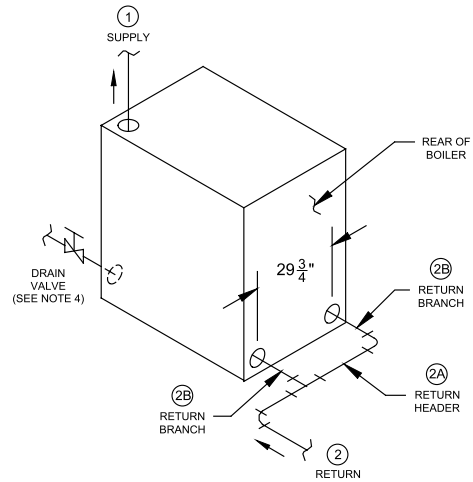

V1109 THRU V1115 (W/20°F DROP)
V1118 THRU V1123 (W/40°F DROP)

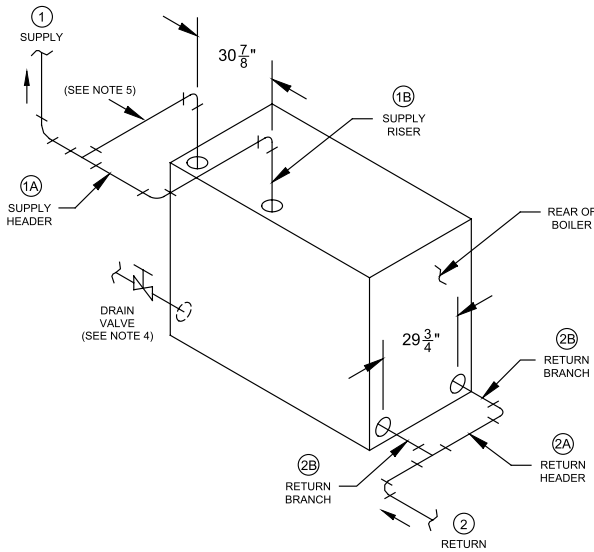

V1116 AND V1117 (W/20°F DROP)

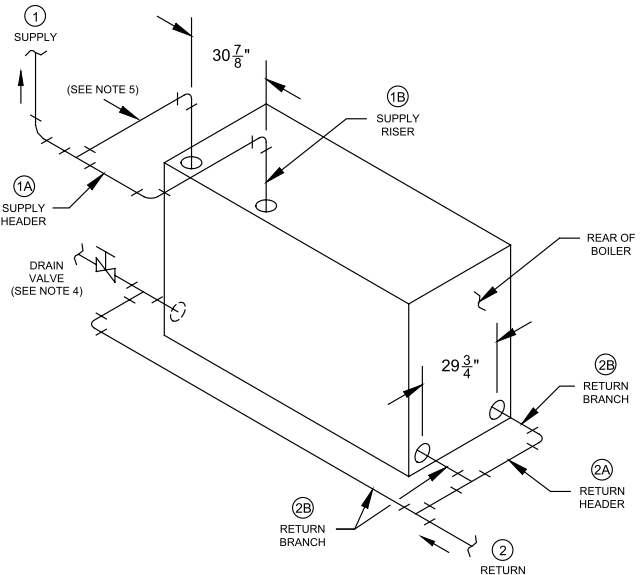

V1118 THRU V1123 (W/20°F DROP)

Pipe Sizing and Notes

BOILER MODEL	SUPPLY PIPING SIZE IN INCHES						RETURN PIPING SIZE IN INCHES					
	(1) SUPPLY		(1A) SUPPLY HEADER		(1B) SUPPLY RISER (QTY.) SIZE		(2) RETURN		(2A) RETURN HEADER		(2B) RETURN BRANCH (QTY.) SIZE	
	20° F DROP	40° F DROP	20° F DROP	40° F DROP	20° F DROP	40° F DROP	20° F DROP	40° F DROP	20° F DROP	40° F DROP	20° F DROP	40° F DROP
V1104	2-1/2	2	—	—	—	—	2-1/2	2	—	—	—	—
V1105	2-1/2	2	—	—	—	—	2-1/2	2	—	—	—	—
V1106	2-1/2	2	—	—	—	—	2-1/2	2	—	—	—	—
V1107	3	2	—	—	—	—	3	2	—	—	—	—
V1108	3	2	—	—	—	—	3	2	—	—	—	—
V1109	4	2-1/2	—	—	—	—	4	2-1/2	3	—	(2) 3	—
V1110	4	2-1/2	—	—	—	—	4	2-1/2	3	—	(2) 3	—
V1111	4	2-1/2	—	—	—	—	4	2-1/2	3	—	(2) 3	—
V1112	4	3	—	—	—	—	4	3	3	—	(2) 3	—
V1113	4	3	—	—	—	—	4	3	3	—	(2) 3	—
V1114	4	3	—	—	—	—	4	3	3	—	(2) 3	—
V1115	4	3	—	—	—	—	4	3	3	—	(2) 3	—
V1116	5	3	3	—	(2) 3	—	5	3	3	—	(2) 3	—
V1117	5	3	3	—	(2) 3	—	5	3	3	—	(2) 3	—
V1118	5	4	4	—	(2) 4	—	5	4	4	3	(3) 3	(2) 3
V1119	5	4	4	—	(2) 4	—	5	4	4	3	(3) 3	(2) 3
V1120	5	4	4	—	(2) 4	—	5	4	4	3	(3) 3	(2) 3
V1121	5	4	4	—	(2) 4	—	5	4	5	3	(3) 3	(2) 3
V1122	5	4	4	—	(2) 4	—	5	4	5	3	(3) 3	(2) 3
V1123	5	4	4	—	(2) 4	—	5	4	5	3	(3) 3	(2) 3

NOTES:

1. All piping is schedule 40.
2. Pipe size listed are based on a 20° F or 40° F differential (temperature drop). Select one to match application.
3. When specified return piping size is less than 3", install 3" x 12" nipple and appropriate size bell reducer directly into boiler return tapping as shown.
4. Drain valve - ball valve preferable, gate valve acceptable alternative (supplied by others).
Minimum valve size per ASME code is 3/4" NPT.
5. Swing joints on two riser systems may be piped over the top of the boiler if space is limited.

V11 Series Minimum Piping Recommendations — Water Boiler

Recommendation 2 — Use when:

- system return water is not less than 135° F for prolonged periods of time
- system flow does impact flow through the boiler (ie. zoning, mixing)

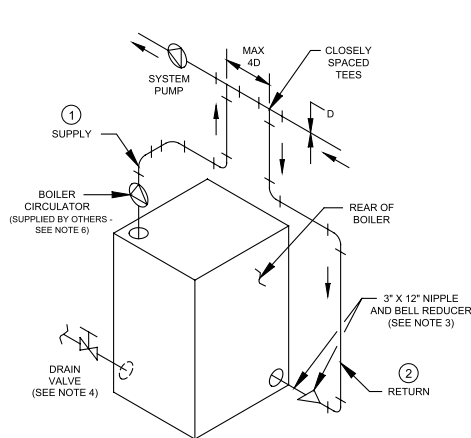

V1104 THRU V1108 (W/20°F DROP)
V1104 THRU V1117 (W/40°F DROP)

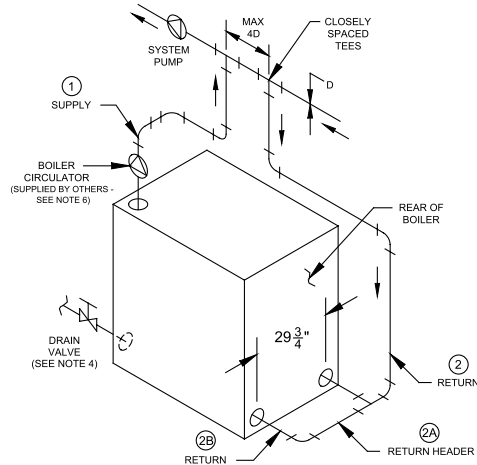

V1109 THRU V1115 (W/20°F DROP)
V1118 THRU V1123 (W/40°F DROP)

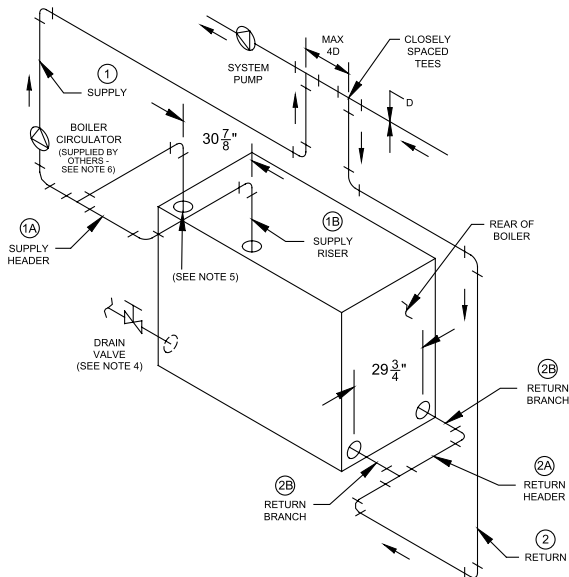

V1116 AND V1117 (W/20°F DROP)

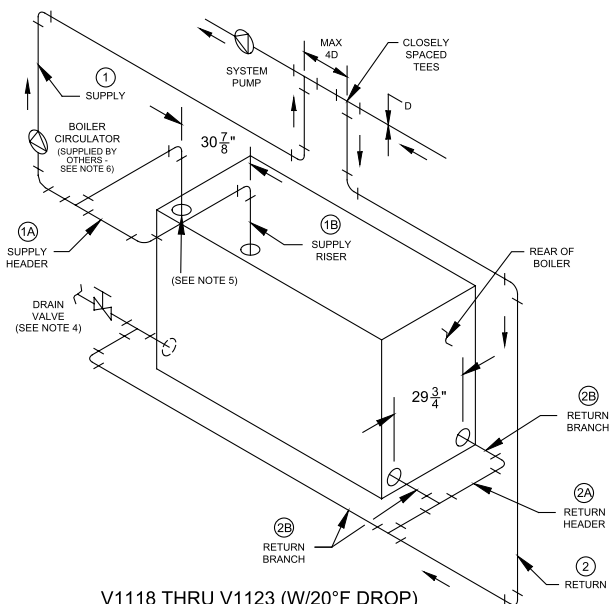

V1118 THRU V1123 (W/20°F DROP)

Pipe Sizing and Notes

BOILER MODEL	SUPPLY PIPING SIZE IN INCHES						RETURN PIPING SIZE IN INCHES					
	(1) SUPPLY		(1A) SUPPLY HEADER		(1B) SUPPLY RISER (QTY. SIZE)		(2) RETURN		(2A) RETURN HEADER		(2B) RETURN BRANCH (QTY. SIZE)	
	20° F DROP	40° F DROP	20° F DROP	40° F DROP	20° F DROP	40° F DROP	20° F DROP	40° F DROP	20° F DROP	40° F DROP	20° F DROP	40° F DROP
V1104	2-1/2	2	—	—	—	—	2-1/2	2	—	—	—	—
V1105	2-1/2	2	—	—	—	—	2-1/2	2	—	—	—	—
V1106	2-1/2	2	—	—	—	—	2-1/2	2	—	—	—	—
V1107	3	2	—	—	—	—	3	2	—	—	—	—
V1108	3	2	—	—	—	—	3	2	—	—	—	—
V1109	4	2-1/2	—	—	—	—	4	2-1/2	3	—	(2) 3	—
V1110	4	2-1/2	—	—	—	—	4	2-1/2	3	—	(2) 3	—
V1111	4	2-1/2	—	—	—	—	4	2-1/2	3	—	(2) 3	—
V1112	4	3	—	—	—	—	4	3	3	—	(2) 3	—
V1113	4	3	—	—	—	—	4	3	3	—	(2) 3	—
V1114	4	3	—	—	—	—	4	3	3	—	(2) 3	—
V1115	4	3	—	—	—	—	4	3	3	—	(2) 3	—
V1116	5	3	3	—	(2) 3	—	5	3	3	—	(2) 3	—
V1117	5	3	3	—	(2) 3	—	5	3	3	—	(2) 3	—
V1118	5	4	4	—	(2) 4	—	5	4	4	3	(3) 3	(2) 3
V1119	5	4	4	—	(2) 4	—	5	4	4	3	(3) 3	(2) 3
V1120	5	4	4	—	(2) 4	—	5	4	4	3	(3) 3	(2) 3
V1121	5	4	4	—	(2) 4	—	5	4	5	3	(3) 3	(2) 3
V1122	5	4	4	—	(2) 4	—	5	4	5	3	(3) 3	(2) 3
V1123	5	4	4	—	(2) 4	—	5	4	5	3	(3) 3	(2) 3

NOTES:

1. All piping is schedule 40.
2. Pipe size listed are based on a 20° F or 40° F differential (temperature drop).
Select one to match application.
3. When specified return piping size is less than 3", install 3" x 12" nipple and appropriate size bell reducer directly into boiler return tapping as shown.
4. Drain valve - ball valve preferable, gate valve acceptable alternative (supplied by others). Minimum valve size per ASME code is 3/4" NPT.
5. Swing joints on two riser systems may be piped over the top of the boiler if space is limited.
6. Proper boiler circulator sizing is listed in RTC literature.

V11 Series Minimum Piping Recommendations — Water Boiler

Recommendation 3 — Use when:

- system return water is less than 135° F for prolonged periods of time
- system flow does impact flow through the boiler (ie. zoning, mixing)
- requires addition of RTC Return Temperature Control and accessories

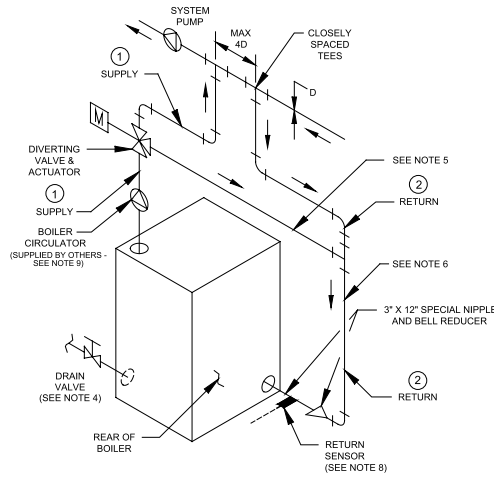

V1104 THRU V1108 (W/20°F DROP)
V1104 THRU V1117 (W/40°F DROP)

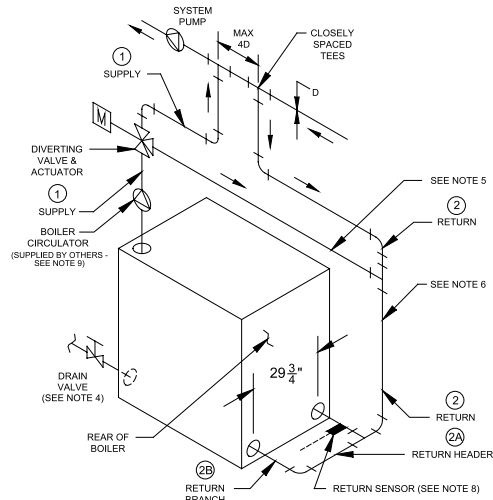

V1109 THRU V1115 (W/20°F DROP)
V1118 THRU V1123 (W/40°F DROP)

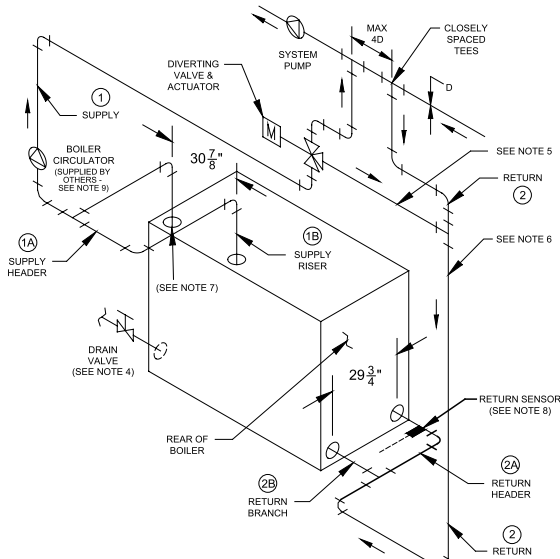

V1116 AND V1117 (W/20°F DROP)

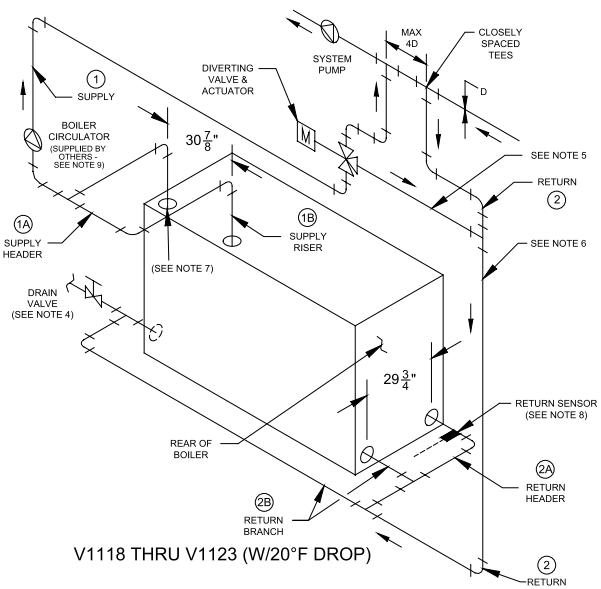

V1118 THRU V1123 (W/20°F DROP)

Pipe Sizing and Notes

BOILER MODEL	SUPPLY PIPING SIZE IN INCHES						RETURN PIPING SIZE IN INCHES					
	(1) SUPPLY		(1A) SUPPLY HEADER		(1B) SUPPLY RISER (QTY.) SIZE		(2) RETURN		(2A) RETURN HEADER		(2B) RETURN BRANCH (QTY.) SIZE	
	20° F DROP	40° F DROP	20° F DROP	40° F DROP	20° F DROP	40° F DROP	20° F DROP	40° F DROP	20° F DROP	40° F DROP	20° F DROP	40° F DROP
V1104	2-1/2	2	—	—	—	—	2-1/2	2	—	—	—	—
V1105	2-1/2	2	—	—	—	—	2-1/2	2	—	—	—	—
V1106	2-1/2	2	—	—	—	—	2-1/2	2	—	—	—	—
V1107	3	2	—	—	—	—	3	2	—	—	—	—
V1108	3	2	—	—	—	—	3	2	—	—	—	—
V1109	4	2-1/2	—	—	—	—	4	2-1/2	3	—	(2) 3	—
V1110	4	2-1/2	—	—	—	—	4	2-1/2	3	—	(2) 3	—
V1111	4	2-1/2	—	—	—	—	4	2-1/2	3	—	(2) 3	—
V1112	4	3	—	—	—	—	4	3	3	—	(2) 3	—
V1113	4	3	—	—	—	—	4	3	3	—	(2) 3	—
V1114	4	3	—	—	—	—	4	3	3	—	(2) 3	—
V1115	4	3	—	—	—	—	4	3	3	—	(2) 3	—
V1116	5	3	3	—	(2) 3	—	5	3	3	—	(2) 3	—
V1117	5	3	3	—	(2) 3	—	5	3	3	—	(2) 3	—
V1118	5	4	4	—	(2) 4	—	5	4	4	3	(3) 3	(2) 3
V1119	5	4	4	—	(2) 4	—	5	4	4	3	(3) 3	(2) 3
V1120	5	4	4	—	(2) 4	—	5	4	4	3	(3) 3	(2) 3
V1121	5	4	4	—	(2) 4	—	5	4	5	3	(3) 3	(2) 3
V1122	5	4	4	—	(2) 4	—	5	4	5	3	(3) 3	(2) 3
V1123	5	4	4	—	(2) 4	—	5	4	5	3	(3) 3	(2) 3

NOTES:

1. All piping is schedule 40.
2. Pipe size listed are based on a 20° F or 40° F differential (temperature drop). Select one to match application.
3. When specified return piping size is less than 3", install 3" x 12" nipple and appropriate size bell reducer into boiler return tapping as shown.
4. Drain valve - ball valve preferable, gate valve acceptable alternative (supplied by others). Minimum valve size per ASME code is 3/4" NPT.
5. Maximum linear feet of pipe from 3-way bypass port to sensor location = 11 feet. Bypass line shall be the same diameter as return ②.
6. Minimum linear feet of pipe from point of mixing (where bypass meets return line) to sensor location = 4 feet.
7. Swing joints on two riser systems may be piped over the top of the boiler if space is limited.
8. Install special 3" x 12" nipple with 1/4" NPT side tapping closest to boiler. Where applicable, use bell reducer to adapt to recommended return piping size.
9. Proper boiler circulator sizing is listed in RTC literature.

V11 Series Burner Schedule

OIL BURNERS

BOILER NUMBER	BECKETT		CARLIN		GORDON-PIATT		POWER FLAME		WEBSTER	
	BURNER MODEL	H.P.	BURNER MODEL	H.P.	BURNER MODEL	H.P.	BURNER MODEL	H.P.	BURNER MODEL	H.P.
V1104	CF1400	1/2	—	—	R8.9-O	1/2	CR1-OS	1/2	JB10-03	1/3
V1105	CF1400	1/2	702CRD	1/2	R8-O	1/2	CR1-OS	1/2	JB10-03	1/3
V1106	CF1400	1/2	702CRD	1/2	R8.1-O	3/4	CR2-OAS	3/4	JB10-03	1/3
V1107	CF2300	3/4	801CRD	3/4	R8.2-O	1	CR2-OAS	3/4	JB10-05	1/2
V1108	CF2300	3/4	801CRD	3/4	R8.3-O	1-1/2	CR2-OAS	3/4	JB10-05	1/2
V1109	CF2300	3/4	801CRD	3/4	R8.3-O	1-1/2	CR2-OAS	3/4	JB10-07	3/4
V1110	CF2300	3/4	1050FFD	1	R8.4-O	2	CR2-OAS	1-1/2	JB10-07	3/4
V1111	CF2300	3/4	1050FFD	1	R10-O	1-1/2	CR3-O	2	JB20-10	1
V1112	CF2500	2	1050FFD	1-1/2	R10-O	2	CR3-O	2	JB20-10	1
V1113	CF2500	2	1050FFD	1-1/2	R10.1-O	2	CR3-O	2	JB20-10	1
V1114	CF3500	2	1150FFD	1-1/2	R10-O	2	CR3-O	2	JB20-10	1
V1115	CF3500	2	1150FFD	1-1/2	R10-O	2	CR3-O	2	JB20-10	1
V1116	CF3500	2	1150FFD	1-1/2	R10.1-O	3	CR3-O	3	JB20-15	1-1/2
V1117	—	—	1150FFD	1-1/2	R10.1-O	3	CR3-O	3	JB20-30	3
V1118	—	—	—	—	R10.2-O	5	CR3-OB	3	JB20-30	3
V1119	—	—	—	—	R10.2-O	5	CR3-OB	3	JB20-30	3
V1120	—	—	—	—	R10.2-O	5	CR3-OB	3	JB20-30	3
V1121	—	—	—	—	R10.2-O	5	CR3-OB	3	JB20-50	5
V1122	—	—	—	—	R10.2-O	5	CR4-OA	5	JB20-50	5
V1123	—	—	—	—	R10.2-O	5	CR4-OA	5	JB20-50	5

Standard Burner Motor Voltage:

Beckett – CF1400, and CF2300 are 120/60/1. CF2500 and CF3500 are 240/60/3.

Carlin – All sizes 240/60/1.

Gordon-Piatt – R8.9-O, R8-O, R8.1-O, and R8.2-O are 120/60/1. All others are 240/60/3.

Power Flame – CR1-OS is 120/60/1. CR2-OAS is 240/60/1. All others are 240/60/3.

Webster – JB10-03, JB10-05 and JB10-07 are 120/60/1. JB20-10 is 240/60/1. All others are 240/60/3.

GAS BURNERS*

BOILER NUMBER	BECKETT			GORDON-PIATT			POWER FLAME - 'CR'†		POWER FLAME - 'JR'†		WEBSTER		
	BURNER MODEL	H.P.	MIN. GAS PRESS. (IN.)	BURNER MODEL	H.P.	MIN. GAS PRESS. (IN.)	BURNER MODEL	H.P.	BURNER MODEL	H.P.	BURNER MODEL	H.P.	MIN. GAS PRESS. (IN.)
V1104	CG10.65	1/3	4.6	R8.9-G	1/2	5.6	CR1-G-12	1/3	JR30A-10	1/3	JB1G-03	1/3	6
V1105	CG10.65	1/3	6.6	R8-G	1/2	5.6	CR1-G-12	1/2	JR30A-12	1/3	JB1G-03	1/3	4
V1106	CG15.4S	1/2	6.2	R8.1-G	3/4	6.5	CR2-G-15	1/2	JR50A-15	1/3	JB1G-03	1/3	6
V1107	CG25.2S	3/4	5.2	R8.2-G	1	6.2	CR2-G-15	1/2	JR50A-15	1/2	JB1G-05	1/2	5
V1108	CG25.3S	3/4	5.0	R8.3-G	1-1/2	6.0	CR2-G-15	1/2	JR50A-15	1/2	JB1G-05	1/2	5
V1109	CG25.4S	3/4	5.2	R8.3-G	1-1/2	6.9	CR2-G-15	1/2	—	—	JB1G-07	3/4	8
V1110	CG25.5S	3/4	5.2	R8.4-G	2	5.8	CR2-G-20A	1	—	—	JB1G-07	3/4	8
V1111	CG50.2S	2	5.7	R10-G	2	6.0	CR3-G-20	1-1/2	—	—	JB2G-10	1	8
V1112	CG50.3S	2	4.3	R10-G	2	6.5	CR3-G-20	1-1/2	—	—	JB2G-10	1	6
V1113	CG50.3S	2	5.7	R10.1-G	2	6.5	CR3-G-20	1-1/2	—	—	JB2G-10	1	7
V1114	CG50.4S	2	5.7	R10-G	2	6.3	CR3-G-20	1-1/2	—	—	JB2G-15	1-1/2	8
V1115	CG50.5S	2	5.0	R10-G	2	6.0	CR3-G-20	1-1/2	—	—	JB2G-30	3	8
V1116	CG50.5S	2	5.3	R10.1-G	3	7.0	CR3-G-25	3	—	—	JB2G-30	3	8
V1117	CG50.5S	2	6.1	R10.1-G	3	6.7	CR3-G-25	3	—	—	JB2G-30	3	9
V1118	CG50.5S	2	6.9	R10.2-G	5	7.2	CR3-G-25B	3	—	—	JB2G-30	3	10
V1119	CG50.5S	2	7.3	R10.2-G	5	7.0	CR3-G-25B	3	—	—	JB2G-30	3	11
V1120	—	—	—	R10.2-G	5	6.8	CR3-G-25B	3	—	—	JB2G-30	3	12
V1121	—	—	—	R10.2-G	5	7.4	CR3-G-25B	3	—	—	JB2G-50	5	14
V1122	—	—	—	R10.2-G	5	7.4	CR4-G-25	3	—	—	JB2G-50	5	15
V1123	—	—	—	R10.2-G	5	6.7	CR4-G-25	3	—	—	JB2G-50	5	16

Standard Motor Voltage:

Gordon-Piatt – R8.9-G, R8-G, R8.1-G and R8.2-G are 120/60/1. All others are 240/60/3.

Power Flame C Series – CR1-G-12 and CR2-G-15 are 120/60/1. CR2-G-20A is 240/60/1. All others are 240/60/3.

Power Flame JR Series – All burners are 120/60/1.

Webster – JB1G-03, JB1G-05 and JB1G-07 are 120/60/1. JB2G-10 is 240/60/1. All others are 240/60/3.

* For inlet gas connection size, see Gas/Oil Burner Chart

† For minimum gas pressure requirements, see Gas/Oil Burner Chart.

GAS/OIL BURNERS

BOILER NUMBER	GORDON-PIATT**			POWER FLAME - 'CR' SERIES				WEBSTER			
	BURNER MODEL	H.P.	INLET GAS CONNECTION (IN.)	BURNER MODEL	H.P.	INLET GAS CONNECTION (IN.)	MIN. GAS PRESS. (IN.)	BURNER MODEL	H.P.	INLET GAS CONNECTION (IN.)	MIN. GAS PRESS. (IN.)
V1104	R8.9-GO	1/2	1	CR1-GO-12	1/2	1	4.7	JB1C-03	1/3	1	7.0
V1105	R8-GO	1/2	1-1/4	CR1-GO-12	1/2	1	4.8	JB1C-03	1/3	1-1/4	4.9
V1106	R8.1-GO	3/4	1-1/4	CR2-GO-15	3/4	1	5.4	JB1C-03	1/3	1-1/4	7.0
V1107	R8.2-GO	1	1-1/2	CR2-GO-15	3/4	1	6.4	JB1C-05	1/2	1-1/4	6.2
V1108	R8.3-GO	1-1/2	1-1/2	CR2-GO-15	3/4	1	7.5	JB1C-05	1/2	1-1/2	6.9
V1109	R8.3-GO	1-1/2	1-1/2	CR2-GO-15	3/4	1-1/4	6.4	JB1C-07	3/4	1-1/2	7.0
V1110	R8.4-GO	2	2	CR2-GO-20A	1-1/2	1-1/4	5.8	JB1C-07	3/4	1-1/2	7.0
V1111	R10-GO	2	2	CR3-GO-20	2	2	5.8	JB2C-10	1	2	6.3
V1112	R10-GO	2	2	CR3-GO-20	2	1-1/2	6.0	JB2C-10	1	2	5.6
V1113	R10.1-GO	2	2-1/2	CR3-GO-20	2	1-1/2	6.8	JB2C-10	1	2	6.3
V1114	R10-GO	2	2	CR3-GO-20	2	1-1/2	7.4	JB2C-10	1	2	7.0
V1115	R10-GO	2	2-1/2	CR3-GO-20	2	1-1/2	7.3	JB2C-10	1	2	6.8
V1116	R10.1-GO	3	2-1/2	CR3-GO-25	3	2	6.6	JB2C-15	1-1/2	2	7.0
V1117	R10.1-GO	3	2-1/2	CR3-GO-25	3	2	7.1	JB2C-30	3	2	7.3
V1118	R10.2-GO	5	3	CR3-GO-25B	3	2	7.7	JB2C-30	3	2-1/2	8.1
V1119	R10.2-GO	5	2-1/2	CR3-GO-25B	3	2-1/2	6.5	JB2C-30	3	2-1/2	9.2
V1120	R10.2-GO	5	3	CR3-GO-25B	3	2-1/2	7.0	JB2C-30	3	2-1/2	10.0
V1121	R10.2-GO	5	3	CR3-GO-25B	3	2-1/2	7.0	JB2C-50	5	2-1/2	11.0
V1122	R10.2-GO	5	3	CR4-GO-25	5	2-1/2	6.3	JB2C-50	5	2-1/2	12.4
V1123	R10.2-GO	5	3	CR4-GO-25	5	2-1/2	6.9	JB2C-50	5	2-1/2	13.1

Standard Burner Motor Voltage:

Gordon-Piatt – R8.9-GO, R8-GO, R8.1-GO and R8.2-GO are 120/60/1. All others are 240/60/3.

Power Flame - CR1-GO-12 is 120/60/1. CR2-GO-15 and CR2-GO-20A are 240/60/1. All others are 240/60/3.

Webster – JB1C-03, JB1C-05, JB1C-07 are 120/60/1. JB2C-10 is 240/60/1. All others are 240/60/3.

**For minimum gas pressure requirements, see Gas Burner Chart.

NOTES: 1. The minimum gas pressures shown are for standard UL burners with the standard firing sequence. IRI, FM and CSD-1 requirements may result in different pressures and prices.

V11 RATINGS



BOILER MODEL (1)	BOILER H.P.	GROSS OUTPUT MBH (2)	I=B=R NET RATING (3)			BURNER INPUT		NET FIREBOX VOLUME (IN. WTR. COLUMN)	PRESSURE IN FIREBOX (IN. WTR. COLUMN)	I=B=R VENT DIA. (IN.)	APPROX. SHIPPING AND LIFTING WEIGHT (LBS.)
			STEAM		WATER MBH	OIL GPH (4)	GAS MBH				
			MBH	SQ. FT.							
V1104	19.9	667	500	2083	580	5.8	837	7.9	.35	8	2105
V1105	25.6	857	643	2679	745	7.4	1068	10.6	.36	8	2510
V1106	31.9	1069	802	3342	930	9.2	1328	13.2	.37	8	2920
V1107	38.3	1281	963	4013	1114	11.0	1588	15.9	.42	10	3325
V1108	45.3	1517	1159	4829	1319	13.0	1876	18.5	.42	10	3733
V1109	51.7	1729	1335	5563	1503	14.8	2136	21.1	.39	10	4147
V1110	58.0	1941	1507	6279	1688	16.6	2396	23.8	.42	12	4557
V1111	64.3	2154	1672	6967	1873	18.4	2656	26.5	.40	12	4964
V1112	69.7	2334	1812	7550	2030	20.0	2887	29.1	.42	12	5374
V1113	74.8	2503	1943	8096	2177	21.5	3103	31.8	.40	12	5771
V1114	81.6	2730	2120	8833	2374	23.5	3392	34.4	.38	14	6184
V1115	88.3	2957	2296	9567	2571	25.5	3680	37.1	.36	14	6601
V1116	93.4	3129	2427	10113	2718	27.0	3897	39.7	.38	14	7008
V1117	100.2	3353	2603	10846	2916	29.0	4186	42.4	.41	14	7417
V1118	106.9	3580	2780	11583	3113	31.0	4474	45.0	.39	16	7823
V1119	111.7	3739	2903	12096	3251	32.5	4691	47.7	.38	16	8231
V1120	118.2	3957	3072	12800	3441	34.5	4979	50.3	.38	16	8638
V1121	124.7	4174	3241	13504	3630	36.5	5268	53.0	.40	16	9053
V1122	129.5	4334	3365	14021	3769	38.0	5485	55.6	.41	18	9456
V1123	136.0	4551	3533	14721	3957	40.0	5733	58.3	.43	18	9865

- Suffix "S" indicates steam boiler, "W" indicates water boiler. Suffix "G" indicates gas-fired, "O" indicates oil fired and "GO" indicates combination gas/oil fired.
- Boiler ratings are based on 13% CO₂ on oil; 10.0% CO₂ on gas, and + .10 in. water column pressure at boiler flue outlet.
- I=B=R net ratings shown are based on piping and pick up allowances which vary from 1.333 to 1.288 for steam and 1.15 for water. Consult manufacturer for installations having unusual piping and pick up requirements, such as intermittent system operation, extensive piping systems, etc.
- The I=B=R burner capacity in GPH is based on oil having a heat value of 140,000 BTU per gallon.

Ratings shown above apply to altitudes up to 1000 feet for oil and 2000 feet for gas. For altitudes above those indicated, the ratings should be reduced at the rate of 4% for each 1000 feet above sea level.

NOTE: Maximum allowable working pressure (MAWP):
 Steam: 15 PSI
 Water – USA: 80 PSI (Standard relief valve provided is 50 PSI) (80 PSI/30 PSI Optional)
 Water – Canada: 50 PSI (Standard relief valve provided is 50 PSI) (30 PSI Optional)

STANDARD EQUIPMENT

ALL BOILERS: Sections unassembled, flush insulated jacket, burner mounting plate, rear observation port cover, fire wall plates, target wall (V1104-1106 only), rear flue outlet damper (top outlet optional), flue canopy, trim, and miscellaneous plugs, bushing and fittings

STEAM TRIM: 15 PSI safety valve, L404A pressuretrol, gauge glass assembly, steam gauge

WATER TRIM: 50 PSI safety relief valve, L4006A high limit, pressure temperature gauge

OIL BOILERS: Flange mounted flame retention oil burner furnished with 2 stage fuel unit, primary control and dual oil valves

GAS BOILERS: Flange mounted gas burner with standard controls meeting the latest UL requirements, dual gas valves, gas-electric ignition with proven gas pilot, flame rod on JR burner, ultra violet flame detector on others, electronic programming controls and components are factory wired in a burner mounted control panel (except JR - panel available as an option)

GAS/OIL BURNERS: Flange mounted combination gas/oil burner with standard controls meeting latest UL requirements, manually operated fuel transfer switch for dual fuel changeover, dual gas valves and oil valves, electric ignition with proven gas pilot on both fuels (direct spark ignition of oil is optional), ultra-violet flame detector, electronic programming controls and components are factory wired in a burner mounted control panel

OPTIONAL EQUIPMENT

Assembled sections; completely packaged (includes manual reset high limit and manual reset low water cutoff); packaged and fire-tested; top outlet flue damper; tankless heaters; side inspection tappings with brass plugs; pressure relief door; 30 PSI and 80 PSI safety relief valves; combustion and hydronic controls to meet special applications including F.M., I.R.I., and ASME CSD-1.



©2006 Burnham Commercial - Lancaster, PA
 Phone: 1-877-567-4328