

Time is Money and Peerless Pump can save you both...

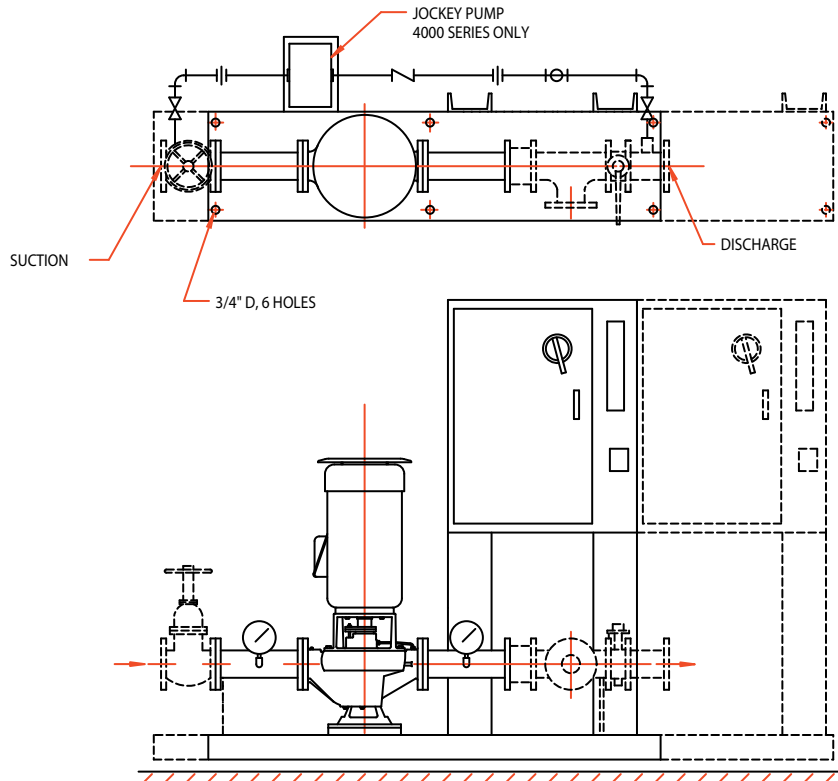

The Peerless Pump PVF Series 2000, 3000 and 4000 Underwriter's Laboratories (U.L.) listed fire pumps are pre-wired packages that include a limited or full service controller. Every package is mounted on a steel fabricated base with the motor wired to the controller. The automatic air relief valve, casing relief valve, suction gauge and discharge gauge are mounted on their respective spool pieces. Additional piping, valves and sensing lines are available with the 3000 and 4000 models. The 4000 model includes a jockey pump and jockey controller.

Features of the PVF Package Systems:

- Capacities up to 750 GPM
- 40 to 165 PSI pump pressures
- Complete, assembled package with fire pump controller mounted and pre-wired to the pump motor
- All components are U.L. listed
- Fast, simple installation
- Limited space requirement
- One complete shipment
- No pump couplings for alignment
- No lost or misplaced parts
- Established installation costs



Series PVF Package Fire Pump System

Typical Specification

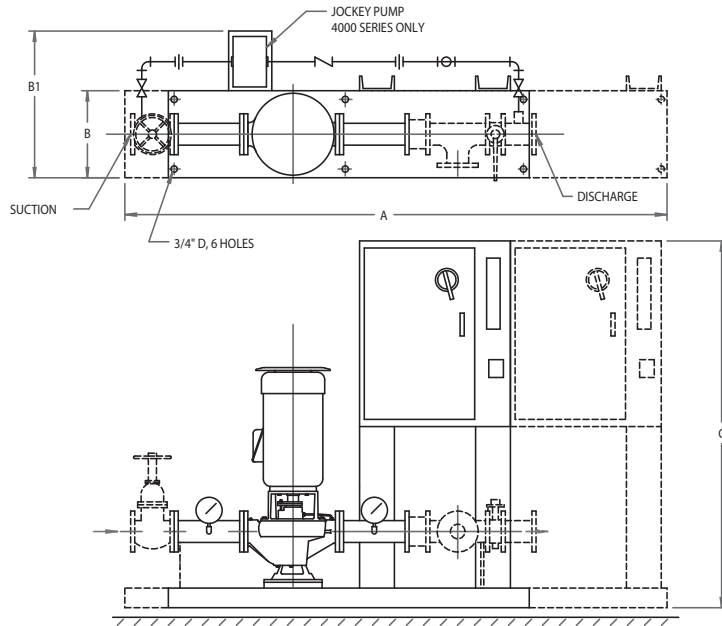

Dimensions - A x B x C

2000 Series

GPM	Limited Service	Full Service
50	70x15x82	n/a
100 to 500	70x15x82	96x15x82
750	70x15x82	96x15x82

3000 Series

GPM	Limited Service	Full Service
50	70x15x82	n/a
100	70x15x82	102x15x82
150	76x15x82	102x15x82
200-250	70x15x82	102x15x82
300	76x15x82	102x15x82
400 to 500	84x15x82	102x15x82
750	84x15x82	102x15x82

4000 Series

GPM	Limited Service	Full Service
50	84x25x82	n/a
100-150	96x25x82	120x25x82
200-250	84x25x82	120x25x82
300-500	96x25x82	120x25x82
750	96x25x82	120x25x82

Furnish and install, where indicated on the plans, one(1) Peerless Pump factory assembled Package Fire Pump System. The system will consist of a PVF in-line fire pump with motor, limited or full service, U.L. (Underwriter's Laboratories) listed and/or FM approved fire pump controller, fabricated steel baseplate with all accessories furnished for a complete package.

SYSTEM REQUIREMENTS. The system will be designed to deliver _____USGPM at a design discharge pressure of _____psi. The pump will be a Peerless model _____ with a motor horsepower of _____. The electrical supply for the motor and the controller will be _____ phase, 50 hertz, _____ volts.

PUMP. Peerless Pump model PVF vertical in-line, U.L. listed or U.L.C. (Underwriter's Laboratories of Canada) listed fire pump. The suction and discharge flanges shall be the same size and shall be displaced 180 degrees with the centerlines on the same horizontal plane. The pump will have a bronze, enclosed impeller, bronze casing wear ring and a bronze shaft sleeve. Shaft sealing will be by a packed type stuffing box or mechanical seal (U.L.C.) with at least five rings of non-asbestos packing and a lantern ring. The lantern ring will be supplied with water from a tap line connected to the discharge of the pump.

MOTOR. The motor will be a NEMA JP or JM frame electric induction motor that is close coupled to the pump. The electric motor will have a maximum service factor of 1.15 and the motor locked rotor current will not exceed the limits as stated in NFPA Pamphlet 20. The motor shall bear the U.L. Label for fire pump service.

FIRE PUMP CONTROLLER. The across-the-line automatic electric motor controller shall be specifically designed for LIMITED OR FULL SERVICE and will be listed by U.L. and/or FM approved. The controller will comply with all requirements of NFPA Pamphlets 20 and 70. The controller will be capable of interrupting a short circuit at least equal to the available fault current of the supply system. All equipment will be enclosed in a locking NEMA type 2 drip-proof, gasketed steel enclosure.

PACKAGING. The PVF fire pump package will be complete including the pump with close coupled motor, limited service or full service controller pre-wired to the pump motor, 3 1/2 inch suction and discharge pressure gauges, flanged discharge spool piece including the discharge pressure gauge, automatic air release valve and casing relief valve. As optional equipment, engineered package systems can include bypass valves and flow meter lines.

All of the above mentioned equipment will be mounted by the fire pump manufacturer, pre-wired and pre-piped on a common structural steel fabricated base to provide a self-contained package system.

INSTALLATION. The contractor will provide a suitable concrete foundation pad. The package will be carefully leveled, secured to the pad and grouted in place. An authorized representative will provide startup service and instruct the owner's representative(s) on the operation and maintenance of the package system.



® Peerless Pump Company
 P.O. Box 7026
 Indianapolis, IN 46207-7026
 (317)925-9661, Fax: (317)924-7388
 www.peerlesspump.com