

ADPL 0.80.3

Progressive Cavity Pump for Metering & Dosing

Features

- * Accurate Flow
- * Close Coupled
- * No Pulsation
- * No Check Valves
- * Fits in Small Spaces
- * Handles High Discharge Pressures

Pump Description

The ADPL 0.80.3 Series of small Low Flow Progressive Cavity Metering and Dosing Pumps from Liberty Process Equipment offers an ideal solution to many low-flow pumping applications that require high accuracy in volume control such as polymer feed for rendering waste treatment at an affordable price. For liquids that are low-viscosity to high-viscosity and abrasive liquids it provides a pumping solution that is much more reliable than other types of metering pumps available on the market today.

Small piston-type metering pumps with check valves have inherent problems of pulsation, sticking and ball check valves sticking and failing. The Liberty ADPL Series solves all of these problems with pulsation free flow, no check valves required and able to handle viscosities up to 20,000 CP. In addition, with its high-accuracy and repeatability it offers a cost-effective alternative to higher-priced "accurate" metering pumps.

All ADPL pumps are available in cast iron and more popular 316 Stainless Steel materials of all wetted parts and are ready to ship same-day from our facility. A wide variety of motors and controls are available for the ADPL from Liberty Process Equipment to meet your exact control needs and budget. All ADPL pumps have a 3/4" NPT female connections. Discharge connections for the ADPL 0.80.3 are 1" NPT Female.

Liberty Process can offer a drive and control option to meet your needs and budget. From a single fixed spaced rotor in AC or DC to a single hand dial to vary the speed to a remote control PLC, Liberty Process Equipment has your low-flow pumping solutions ready to ship same day. Contact us today for a quote and see the difference the ADPL 0.80.3 can make in your low-flow pumping applications.

Materials

Rotor: *Chrome Plated 316 Stainless Steel*

Stator: *Buna, Viton™*

Motor: *1/2 hp*

Inlet: *1"*

Outlet: *1"*

Bases: *Steel and Stainless Steel*

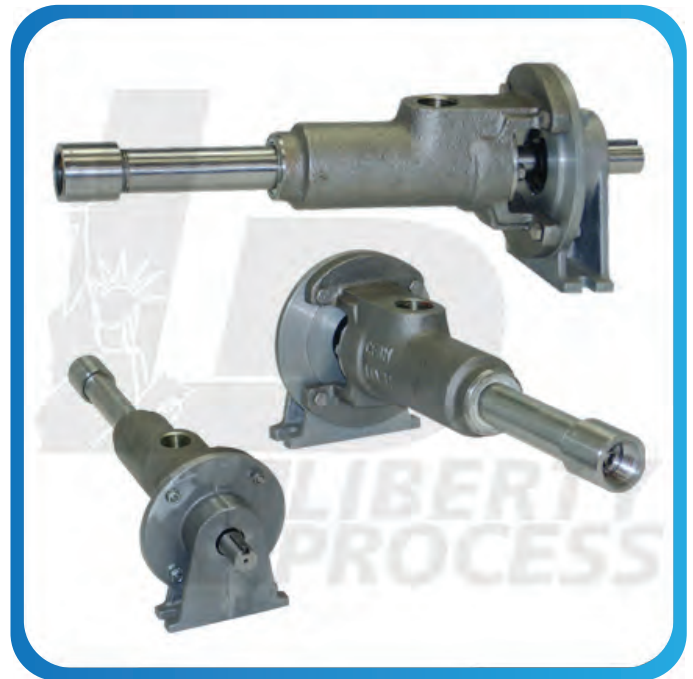

ADPL 0.80.3

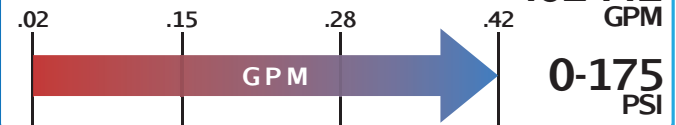

Curves

ADPL
0.80.3



Please
Click
the Icon

Drawings

ADPL
0.80.3



Please
Click
the Icon

Click To Visit www.libertyprocess.com >>



Liberty Process Equipment, Inc.
2525 S Clearbrook Dr.
Arlington Heights, IL 60005-4623
P-(847) 640-7867
F-(847) 640-7855
sales@libertyprocess.com

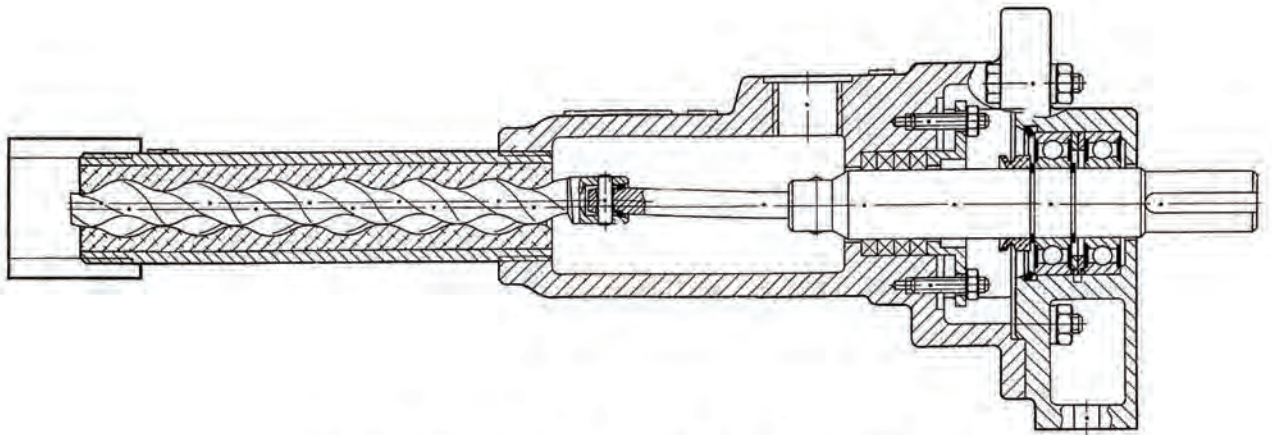

ADPL 0.80

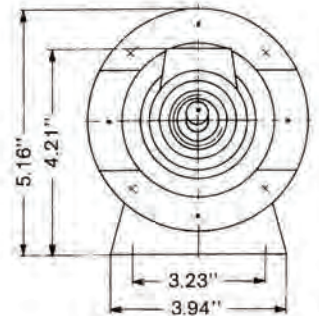
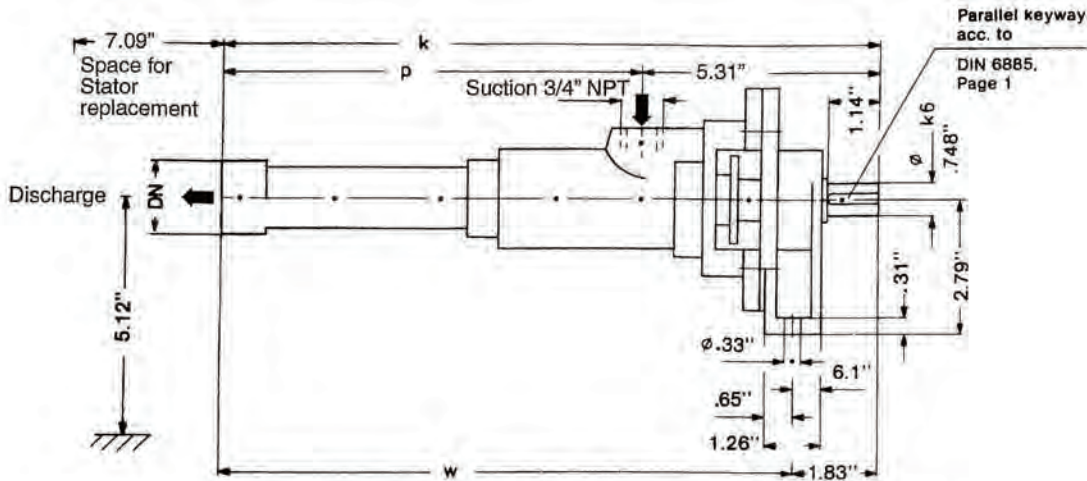

Possible port positions looking from drive end
1 = standard

| Pump Size | Disch. DN | Pump dimensions | | | Weight Appr. | | | | |
|-----------|-----------|-----------------|----------|-----|--------------|-------|----------|-----|------|
| | | mm | k inches | mm | p inches | mm | w inches | kg | lbs. |
| 0.4 | NPT 1/2 | 343 | / 13.50" | 208 | / 8.19" | 296.5 | / 11.67" | 3.3 | 7.3 |
| 0.8 | NPT 3/4 | 368 | / 14.49" | 233 | / 9.17" | 321.5 | / 12.65" | 3.5 | 7.7 |
| 1.5 | NPT 1 | 399 | / 15.70" | 264 | / 10.39" | 352.5 | / 13.88" | 3.8 | 8.4 |

① Minimum space to mounting surface with stuffing box versions, when connection NPT 3/4 horizontally (branch position 2 or 4).

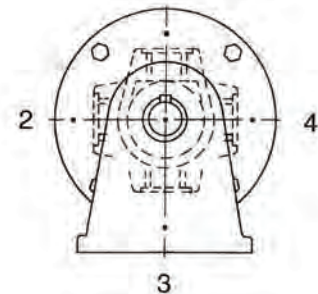

ADPL 0.80.3

Typical Performance Curve for water at 68 Deg. F.

Size - 0.80

Stage(s) - 3

Starting Torque = 1.3 to 2.6 ft. lb

Max Pres. = 175 PSI

RPM = 0-500

