



B42 Series Regulator



Advanced Metering
and Regulation
Technology at Work

Features

Interchangeable aluminum orifice
12.6 in² of diaphragm area
Molded deep convolution diaphragm with o-ring seal
Plated steel diaphragm plate
Stainless steel lever pin
Plated steel 6:1 lever
One piece molded Buna-N valve seat
Die cast zinc valve stem
Delrin[®] vent valve with Buna-N seat
Spring loaded internal relief valve assembly
1" and 3/4" threaded vent with stainless steel screen
Fiberglass reinforced polyethylene seal cap with integral relief valve stop
Field interchangeable adjustment spring
CSA 6-18 Approved
Measurement Canada Approved - G108
B109.4 Compliant

Benefits

Increased Safety
Long Service Life
Easier Installation
Easier Transport

Application

Consistent pressure reduction of gas for typical domestic and light commercial applications.

Designed to Increase Your Customer's Satisfaction and Reduce Your Total Costs

The model B42 is uniquely constructed to give utilities the edge they need in an increasingly complex and competitive marketplace. The model B42 excels with benefits of size, safety, performance, and cost. The B42 also offers three connection versions providing the greatest flexibility for your regulation needs. In addition, due to inventory and manufacturing enhancements this product can be delivered with unparalleled speed and scheduling dependability.

Compact Size

While the model B42 is more compact than traditional regulators, it was also designed to meet customer expectations for safety and long field life. The B42 is designed to consolidate product usage for both residential and light commercial applications.

Description

The B-42 is a spring loaded self operated regulator with internal relief. The B42 features a molded diaphragm, 6:1 lever ratio and a one inch vent. The benefit is a lighter more compact unit that provides the power, capacity and relief performance of larger regulators

B42N The B42N is a spring loaded self-operated regulator with no internal relief (N) valve. This model can be used on low or intermediate inlet pressures where an internal relief, or other type of over-pressure protection device is not required.

B42R -The B42R is the internal relief (R) version of the B42 Series. The large 1" internal relief valve provides exceptional relief capacity.

Option Designations

N — No Internal Relief
R — Internal Relief

Actaris takes pride in delivering American made products with the utmost concern for safety, quality and customer satisfaction.

- 1 - All metal restricting orifice
- 2 - Full 1" relief vent
- 3 - Field interchangeable springs
- 4 - Dual positive relief stops
- 5 - All metal linkage
- 6 - Integral o-ring diaphragm seal
- 7 - Mechanically fastened ID tag
- 8 - 1-piece valve seat design

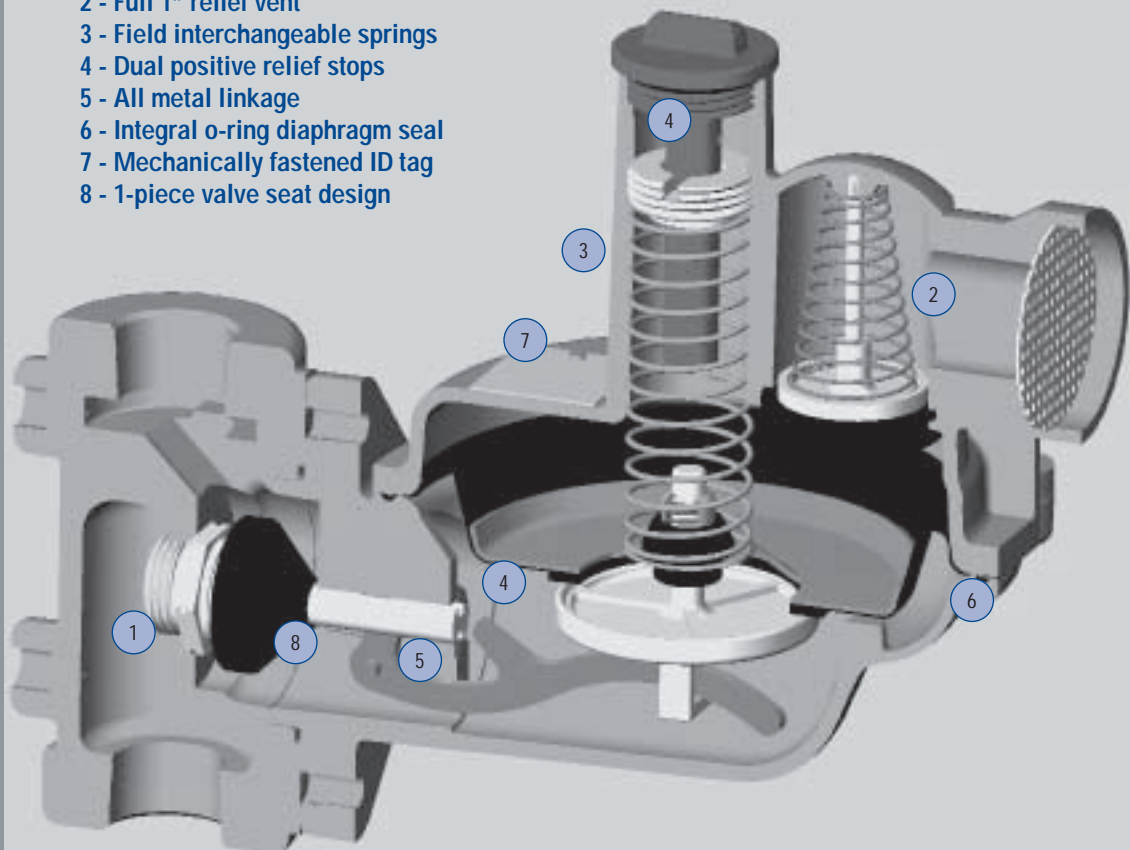

Model B42 Series regulators exceed all AGA/ANSI B109.4 & CSA 6-18 specifications



Specifications

Material Construction:

Valve Body:	High tensile strength cast iron (ASTM A-126, Class A)
Orifice	Aluminum
Valve Seat:	Buna-N or silicone
Valve Stem:	Die cast zinc
Lever Pin:	Stainless steel (Type 303)
Lever:	Zinc and dichromate plated steel (AISI C1010)
Upper Diaphragm Plate:	Zinc and dichromate plated steel (14 gauge steel)
Lower Diaphragm Plate:	Isoplast
Diaphragm:	Buna-N on Dacron reinforcing fabric
Vent Valve/Seat:	Neoprene
Vent Screen:	Stainless Steel (16 mesh)
Adjustment Ferrule:	Delrin
Seal Cap:	Fiberglass reinforced polyethylene
Diaphragm Case:	Die cast aluminum (ASTM B85 –Alloy SC84A)
Fastener Plating:	Dacromet with Plus Black

Shipping Weight:

12 per box: 48 lbs.

Correction factors for non-natural gas applications:

The B42 may be used to control gases other than natural gas. To determine the capacity of the B42 for gases other than natural gas, it will be necessary to multiply the values within the capacity tables by a correction factor. The table below lists the correction factors for some of the more common gases:

Gas Type	Specific Gravity	Correction Factor (CF)
Air	1.0	0.77
Butane	2.01	0.55
Carbon Dioxide (Dry)	1.52	0.63
Carbon Monoxide (Dry)	0.97	0.79
Natural Gas	0.60	1.00
Nitrogen	0.97	0.79
Propane	1.53	0.63
Propane-Air-Mix	1.20	0.71

To calculate the correction factor for gases not listed on the table above, it will be necessary to know the specific gravity of the gas and use it in the formula listed below:
Correction Factor (CF) = $\sqrt{\frac{SG_1}{SG_2}}$

Where:
SG₁ = Specific Gravity of the gas in which the capacity is published.
SG₂ = Specific Gravity of the gas to be controlled.

Standard Spring Data - B42	Spring Color	Outlet Pressure Range**
	Green (p/n 762649)	5 - 7" w.c.
	Brown (p/n 762645)	6 - 8" w.c.
	Blue (p/n 762646)	8 - 14" w.c.
	Silver (p/n 762647)	12 - 28" w.c.
	Yellow/Black (p/n 762650)	1 - 2 PSIG
Alternate Spring Data - B42		
	Orange (p/n 762002)	5.5 - 9" w.c.
	Dark Green (p/n 762003)	4 - 9" w.c.
High Pressure Spring Data - B42		
	Yellow (p/n 762131)	2 - 4 PSIG
	White (p/n 762137)	4 - 5 PSIG
Relief Spring Data - B42		
	Purple (p/n 762653)	7" w.c. Above Set Point
	Red (p/n 762655)	5" w.c. Above Set Point

**Note: Ranges are approximations, please contact manufacture to obtain the best spring for application.

Orifice Data	Size	K-Factor	MAOP	Emergency Inlet	Emergency Outlet	
					No Damage	Containment
	1/8"	30	125 PSIG	300 PSIG	60 PSIG	30 PSIG
	1/8" x 3/16"	30	125 PSIG	300 PSIG	60 PSIG	30 PSIG
	3/16"	71	125 PSIG	200 PSIG	60 PSIG	30 PSIG
	1/4"	127	60 PSIG	150 PSIG	60 PSIG	30 PSIG
	5/16"	193	35 PSIG	100 PSIG	60 PSIG	30 PSIG
	3/8"	290	20 PSIG	75 PSIG	60 PSIG	30 PSIG
	1/2"	416	10 PSIG	40 PSIG	60 PSIG	30 PSIG
	1/2" x 9/16"	416	10 PSIG	40 PSIG	60 PSIG	30 PSIG

Wide-Open Flow Calculations

For wide-open orifice flow calculations use the following equations:

For $P_1/P_2 < 1.89$ use: $Q = K \sqrt{P_2 (P_1 - P_2)}$ For $P_1/P_2 > 1.89$ use: $Q = \frac{KP_1}{2}$

Where: P₁ = absolute inlet pressure (psia)
Q = flow rate (scfh)

P₂ = absolute outlet pressure (psia)
K = orifice coefficient (scfh/psi)

Straight Body Connection

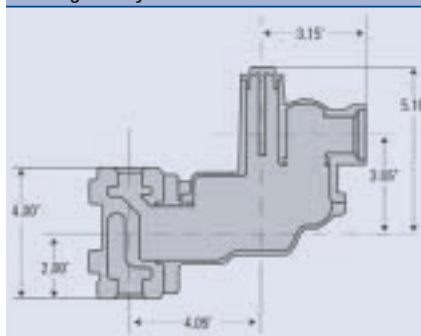

90 Angle Body Connection

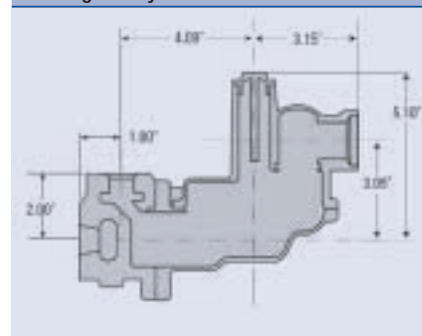

Compact Body Connection

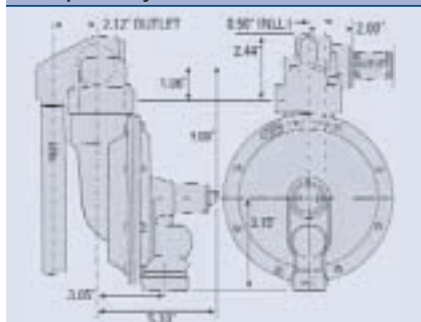

Connection Sizes

Inlet	Outlet	Compact	90 Angle	Straight
1/2"	1/2"	-	X	X
1/2"	3/4"	-	X	X
1/2"	1"	-	X	-
3/4"	3/4"	X	X	X
3/4"	1"	X	X	X
3/4"	1-1/4"	-	-	X
1"	1"	-	X	X
1"	1-1/4"	-	-	X
1-1/4"	1-1/4"	-	-	X

7" w.c. (17 mbar) - B42 Residential Regulator Capacity Table (1" Droop) - Models N, R

Green Spring (762649)

Position 5

1" NPT Outlet

Capacities in scfh (m ³ /hr) - Orifice Size									
Inlet Pressure		1/8"	1/8 x 3/16"	3/16"	1/4"	5/16"	3/8"	1/2"	1/2 x 9/16"
PSIG	Bar	3.2 mm	3.2 x 4.8 mm	4.8 mm	6.4 mm	7.9 mm	9.5 mm	12.7 mm	12.7 x 14.3 mm
0.5	38 mbar	65 (1.8)	70 (2.0)	90 (2.5)	140 (3.9)	175 (4.9)	210 (5.9)	270 (7.6)	280 (7.9)
1	69 mbar	80 (2.3)	110 (3.1)	140 (3.9)	200 (5.7)	275 (7.8)	300 (8.5)	400 (11.3)	450 (12.7)
2	0.138	100 (2.8)	180 (5.1)	225 (6.4)	250 (7.1)	375 (10.6)	425 (12.0)	600 (17.0)	700 (19.8)
3	0.207	170 (4.8)	225 (6.4)	310 (8.8)	350 (9.9)	500 (14.2)	575 (16.3)	800 (22.7)	910 (25.8)
5	0.345	215 (6.1)	280 (7.9)	400 (11.3)	500 (14.2)	725 (20.5)	825 (23.4)	1100 (31.1)	1230 (34.8)
10	0.69	340 (9.6)	390 (11.0)	625 (17.7)	850 (24.1)	1100 (31.1)	1300 (36.8)	Orifice Inlet Pressure Rating Exceeded	
15	1.03	425 (12.0)	470 (13.3)	850 (24.1)	1200 (34.0)	1550 (43.9)	1650 (46.7)		
20	1.38	550 (15.6)	550 (15.6)	1100 (31.1)	1450 (41.1)	1850 (52.4)			
30	2.07	700 (19.8)	700 (19.8)	1400 (39.6)	2000 (56.6)				
40	2.76	850 (24.1)	870 (24.6)	1750 (49.6)	2200 (62.3)				
50	3.45	1000 (28.3)	1020 (28.9)	2150 (60.9)	2500 (70.8)				
60	4.13	1150 (32.6)	1190 (33.7)	2300 (65.1)	2500 (70.8)				
80	5.51	1500 (42.5)	1590 (45.0)	2400 (68.0)					
100	6.89	1800 (51.0)	1870 (53.0)	2500 (70.8)					
125	8.61	2200 (62.3)	2280 (63.0)	2500 (70.8)					
Inlet Effect ^B		0.13" w.c.	0.13" w.c.	0.20" w.c.	0.36" w.c.	0.67" w.c.	0.77" w.c.	2.20" w.c.	2.20" w.c.
Lock Up ^C		0.5" w.c.	0.5" w.c.	0.6" w.c.	0.7" w.c.	0.8" w.c.	0.9" w.c.	1.2" w.c.	1.2" w.c.

Typical Performance Curves

Manufacturer.....Actaris

Type and Model.....B42 R

Regulator:

Inlet Size.....3/4" NPT

Outlet Size.....1" NPT

Orifice Size.....3/16"

Spring.....Green (p/n 762649)

Set Point 7.0" w.c. with 10 psig inlet @ 50 scfh. All test results are reported at a base of 14.7 psia and 60 F.

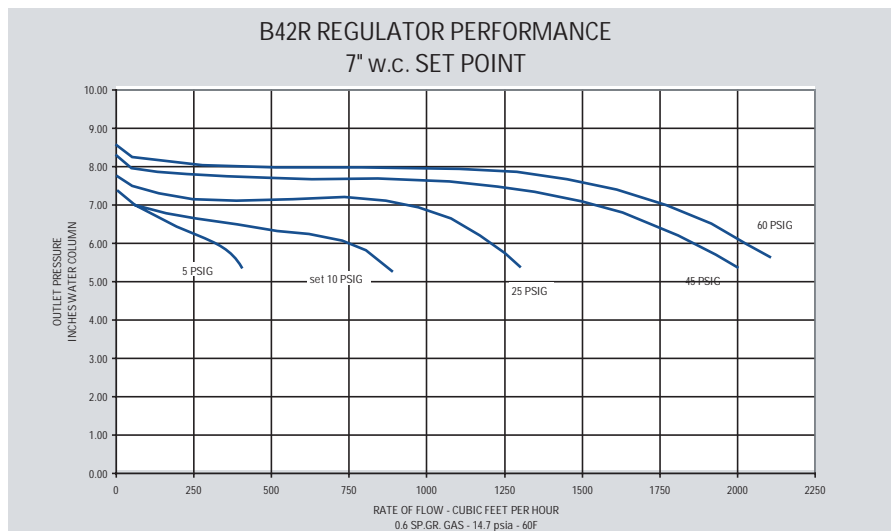

Relief Characteristic Curves R Model Only

Manufacturer.....Actaris

Type and Model.....B42 R

Regulator:

Inlet Size.....3/4" NPT

Outlet Size.....1" NPT

Vent Size.....1" NPT

Set Point 7.0" w.c. with 10 psig inlet @ 50 scfh. All test results are reported at a base of 14.7 psia and 60 F.

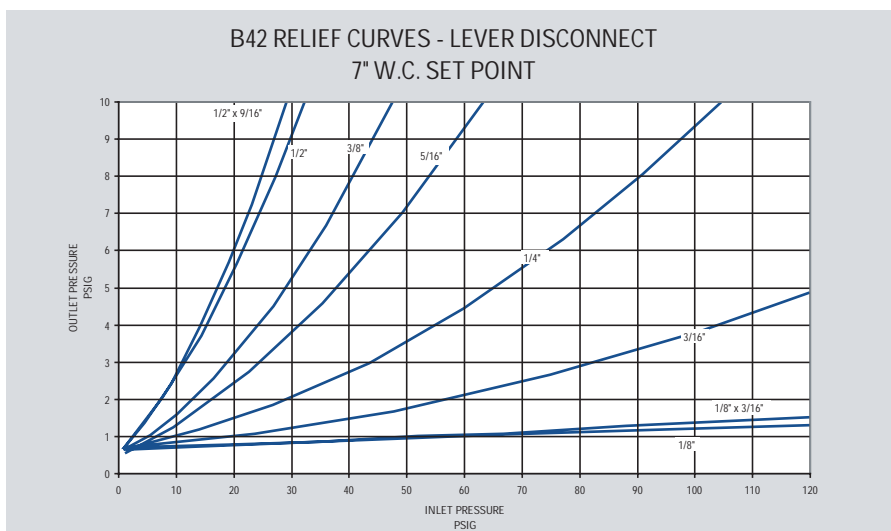

Note:
A- Capacity in grey outline generated with Brown Sprg (762645)
B- Change in outlet pressure for 10 PSIG inlet pressure change
C- Outlet pressure increase required for lock up

14" w.c. (34 mbar) - B42 Residential Regulator Capacity Table (2" Droop) - Models N, R

Blue Spring (762646)

Position 5

1" NPT Outlet

Capacities in scfh (m ³ /hr) - Orifice Size									
Inlet Pressure		1/8"	1/8 x 3/16"	3/16"	1/4"	5/16"	3/8"	1/2"	1/2 x 9/16"
PSIG	Bar	3.2 mm	3.2 x 4.8 mm	4.8 mm	6.4 mm	7.9 mm	9.5 mm	12.7 mm	12.7 x 14.3 mm
1	69 mbar				190 (5.38)	270 (7.65)	280 (7.93)	550 (15.57)	575 (16.28)
2	0.138		190 (5.38)	220 (6.23)	300 (8.50)	430 (12.18)	450 (12.74)	820 (23.22)	860 (24.35)
3	0.207	160 (4.53)	215 (6.09)	300 (8.50)	380 (10.76)	550 (15.57)	560 (15.86)	1030 (29.17)	1080 (30.58)
5	0.345	230 (6.51)	280 (7.93)	390 (11.04)	550 (15.57)	710 (20.10)	740 (20.95)	1230 (34.83)	1310 (37.10)
10	0.69	370 (10.48)	390 (11.04)	600 (16.99)	820 (23.22)	1050 (29.73)	1130 (32.00)	1605 (45.45)	1680 (47.57)
15	1.03	460 (13.03)	525 (14.87)	800 (22.65)	1070 (30.30)	1340 (37.94)	1460 (41.34)	Orifice Inlet Pressure Rating Exceeded	
20	1.38	610 (17.27)	700 (19.82)	1000 (28.32)	1320 (37.38)	1630 (46.16)	1800 (50.97)		
30	2.07	800 (22.65)	890 (25.20)	1340 (37.94)	1750 (49.55)	1950 (55.22)			
40	2.76	1030 (29.17)	1150 (32.56)	1750 (49.55)	2050 (58.05)				
50	3.45	1200 (33.98)	1300 (36.81)	2010 (56.92)	2300 (65.13)				
60	4.13	1310 (37.10)	1425 (40.35)	2250 (63.71)	2500 (70.79)				
80	5.51	1900 (53.80)	2000 (56.63)	2580 (73.06)					
100	6.89	2200 (62.30)	2275 (64.42)	2700 (76.46)					
125	8.61	2200 (62.30)	2275 (64.42)	2900 (82.12)					

Inlet Effect ^B	0.12" w.c.	0.12" w.c.	0.22" w.c.	0.33" w.c.	0.50" w.c.	0.71" w.c.	2.3" w.c.	2.3" w.c.
Lock Up ^C	0.6" w.c.	0.6" w.c.	0.7" w.c.	0.8" w.c.	0.9" w.c.	1.0" w.c.	1.3" w.c.	1.3" w.c.

Typical Performance Curves

Manufacturer.....Actaris
 Type and Model.....B42 R
 Regulator:
 Inlet Size3/4" NPT
 Outlet Size.....1" NPT
 Orifice Size3/16"
 SpringBlue (p/n 762646)
 Set Point 14.0" w.c. with 10 psig inlet @ 50 scfh. All test results are reported at a base of 14.7 psia and 60 F.

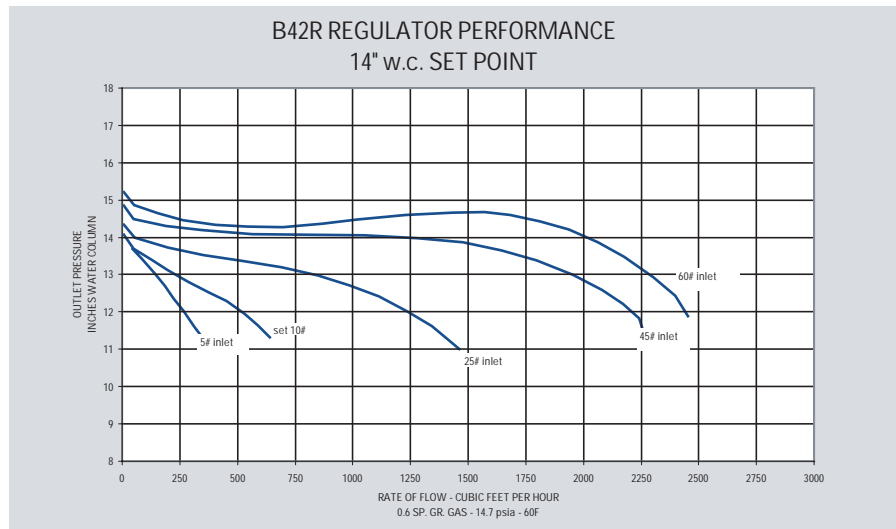

Relief Characteristic Curves R Model Only

Manufacturer.....Actaris
 Type and Model.....B42 R
 Regulator:
 Inlet Size3/4" NPT
 Outlet Size.....1" NPT
 Vent Size1" NPT
 Set Point 14.0" w.c. with 10 psig inlet @ 50 scfh. All test results are reported at a base of 14.7 psia and 60 F.

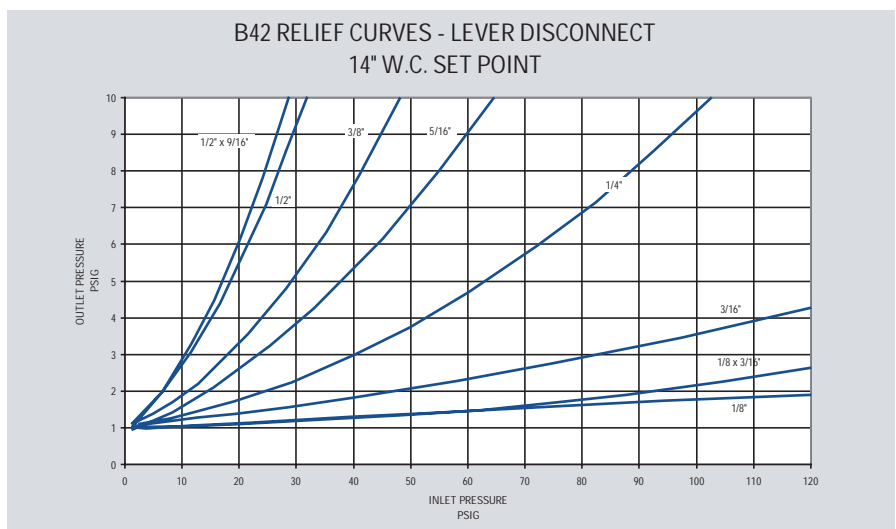

Note:
 B- Change in outlet pressure for 10 PSIG inlet pressure change
 C- Outlet pressure increase required for lock up

1 PSIG (69 mbar) - B42 Residential Regulator Capacity Table (1% Droop) - Models N, R

Silver Spring (762647)

Position 5

1" NPT Outlet

Capacities in scfh (m ³ /hr) - Orifice Size									
Inlet Pressure		1/8"	1/8 x 3/16"	3/16"	1/4"	5/16"	3/8"	1/2"	1/2 x 9/16"
PSIG	Bar	3.2 mm	3.2 x 4.8 mm	4.8 mm	6.4 mm	7.9 mm	9.5 mm	12.7 mm	12.7 x 14.3 mm
2	0.14			230 (6.51)	300 (8.50)	330 (9.34)	420 (11.89)	455 (12.88)	475 (13.45)
3	0.21	160 (4.53)	225 (6.37)	300 (8.50)	400 (11.33)	450 (12.74)	540 (15.29)	615 (17.41)	670 (18.97)
5	0.34	230 (6.51)	300 (8.50)	385 (10.90)	490 (13.88)	650 (18.41)	700 (19.82)	790 (22.37)	1035 (29.31)
10	0.69	365 (10.34)	425 (12.03)	570 (16.14)	770 (21.80)	1020 (28.88)	1130 (32.00)	1145 (32.42)	1575 (44.60)
15	1.03	460 (13.03)	550 (15.57)	770 (21.80)	1050 (29.73)	1270 (35.96)	1410 (39.93)		
20	1.38	570 (16.14)	675 (19.11)	980 (27.75)	1350 (38.23)	1550 (43.89)	1710 (48.42)		
30	2.07	780 (22.09)	875 (24.78)	1330 (37.66)	1850 (52.39)	2000 (56.63)			
40	2.76	980 (27.75)	1100 (31.15)	1760 (49.84)	2250 (63.71)				
50	3.45	1150 (32.56)	1225 (34.69)	2140 (60.60)	2600 (73.62)				
60	4.14	1270 (35.96)	1350 (38.23)	2400 (67.96)	2850 (80.70)				
80	5.52	1700 (48.14)	1900 (53.80)	2890 (81.84)					
100	6.89	1900 (53.80)	2150 (60.88)	3150 (89.20)					
125	8.62	2100 (59.47)	2275 (64.42)	3300 (93.45)					

Orifice Inlet Pressure Rating Exceeded

Capacity Table (2% Droop) - Models N, R

Capacities in scfh (m ³ /hr) - Orifice Size									
Inlet Pressure		1/8"	1/8 x 3/16"	3/16"	1/4"	5/16"	3/8"	1/2"	1/2 x 9/16"
PSIG	Bar	3.2 mm	3.2 x 4.8 mm	4.8 mm	6.4 mm	7.9 mm	9.5 mm	12.7 mm	12.7 x 14.3 mm
2	0.14			250 (7.08)	480 (13.59)	610 (17.27)	700 (19.82)	790 (22.37)	850 (24.07)
3	0.21	170 (4.81)	225 (6.37)	400 (11.33)	620 (17.56)	880 (24.92)	980 (27.75)	1070 (30.30)	1120 (31.71)
5	0.34	260 (7.36)	325 (9.20)	570 (16.14)	810 (22.94)	1060 (30.02)	1200 (33.98)	1265 (35.82)	1600 (45.31)
10	0.69	410 (11.61)	500 (14.16)	840 (23.79)	1270 (35.96)	1600 (45.31)	1850 (52.39)	2020 (57.20)	2220 (62.86)
15	1.03	510 (14.44)	600 (16.99)	1050 (29.73)	1600 (45.31)	2000 (56.63)	2175 (61.59)		
20	1.38	610 (17.27)	750 (21.24)	1260 (35.68)	2020 (57.20)	2400 (67.96)	2500 (70.79)		
30	2.07	780 (22.09)	875 (24.78)	1630 (46.16)	2600 (73.62)	2900 (82.12)			
40	2.76	980 (27.75)	1100 (31.15)	2000 (56.63)	3000 (84.95)				
50	3.45	1150 (32.56)	1125 (31.86)	2410 (68.24)	3300 (93.45)				
60	4.14	1270 (35.96)	1350 (38.23)	2750 (77.87)	3450 (97.69)				
80	5.52	1700 (48.14)	1900 (53.80)	3410 (96.56)					
100	6.89	1900 (53.80)	2150 (60.88)	3600 (101.94)					
125	8.62	2100 (59.47)	2275 (64.42)	3800 (107.60)					

Orifice Inlet Pressure Rating Exceeded

Inlet Effect ^B	0.01 PSIG	0.01 PSIG	0.01 PSIG	0.02 PSIG	0.03 PSIG	0.04 PSIG	0.05 PSIG	0.05 PSIG
Lock Up ^C	0.05 PSIG	0.05 PSIG	0.07 PSIG	0.08 PSIG	0.09 PSIG	0.11 PSIG	0.13 PSIG	0.13 PSIG

Note:

B- Change in outlet pressure for 10 PSIG inlet pressure change
C- Outlet pressure increase required for lock up

1 PSIG (69 mbar) - B42 Residential Regulator - Models N, R

Typical Performance Curves

Manufacturer.....Actaris
 Type and Model.....B42 R
 Regulator:
 Inlet Size3/4" NPT
 Outlet Size.....1" NPT
 Orifice Size3/16"
 SpringSilver (p/n 762647)
 Set Point 1PSIG with 10 psig inlet @ 50 scfh. All test results are reported at a base of 14.7 psia and 60 F.

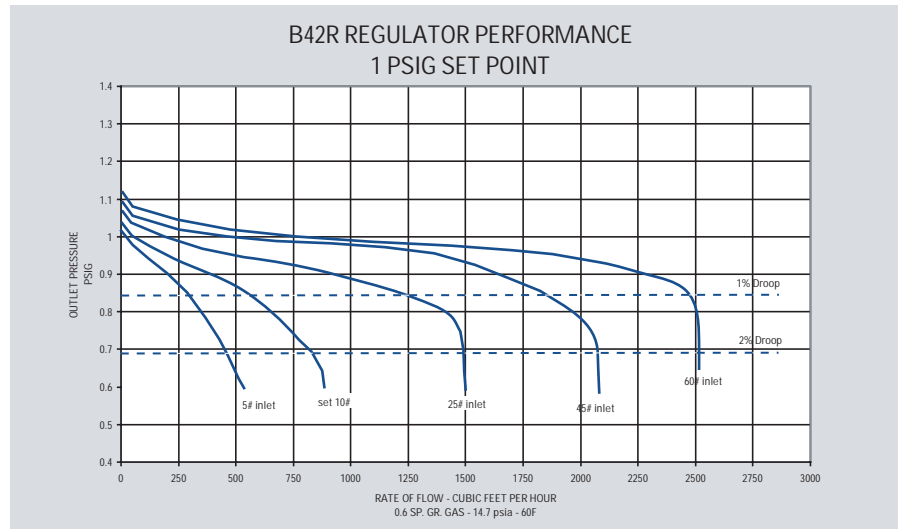

Relief Characteristic Curves R Model Only

Manufacturer.....Actaris
 Type and Model.....B42 R
 Regulator:
 Inlet Size3/4" NPT
 Outlet Size.....1" NPT
 Vent Size1" NPT
 Set Point 1 PSIG with 10 psig inlet @ 50 scfh. All test results are reported at a base of 14.7 psia and 60 F.

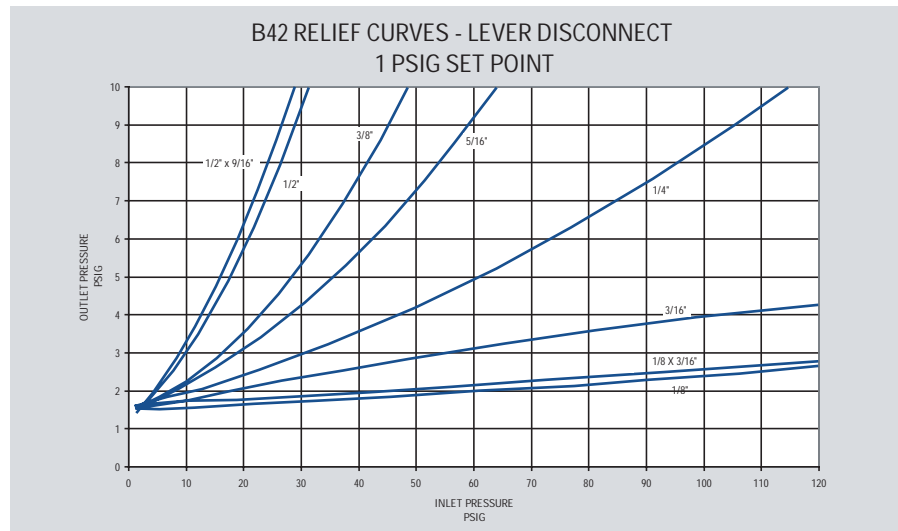

2 PSIG (0.14 bar) - B42 Residential Regulator Capacity Table (1% Droop) - Models N, R

Yellow/Black Spring (762650)

Position 5

1" NPT Outlet

Capacities in scfh (m ³ /hr) - Orifice Size									
Inlet Pressure		1/8"	1/8 x 3/16"	3/16"	1/4"	5/16"	3/8"	1/2"	1/2 x 9/16"
PSIG	Bar	3.2 mm	3.2 x 4.8 mm	4.8 mm	6.4 mm	7.9 mm	9.5 mm	12.7 mm	12.7 x 14.3 mm
3	0.21	100 (2.83)	120 (3.40)	160 (4.53)	200 (5.66)	270 (7.65)	280 (7.93)	320 (9.06)	340 (9.63)
5	0.34	135 (3.82)	170 (4.81)	230 (6.51)	290 (8.21)	400 (11.33)	420 (11.89)	480 (13.59)	575 (16.28)
10	0.69	230 (6.51)	295 (8.35)	370 (10.48)	490 (13.88)	730 (20.67)	750 (21.24)	840 (23.79)	1075 (30.44)
15	1.03	300 (8.50)	415 (11.75)	500 (14.16)	650 (18.41)	1000 (28.32)	1000 (28.32)	Orifice Inlet Pressure Rating Exceeded	
20	1.38	370 (10.48)	550 (15.57)	600 (16.99)	840 (23.79)	1200 (33.98)	1200 (33.98)		
30	2.07	500 (14.16)	700 (19.82)	900 (25.49)	1230 (34.83)	1600 (45.31)			
40	2.76	600 (16.99)	880 (24.92)	1100 (31.15)	1600 (45.31)				
50	3.45	800 (22.65)	1090 (30.87)	1400 (39.64)	1940 (54.93)				
60	4.14	950 (26.90)	1250 (35.40)	1600 (45.31)	2240 (63.43)				
80	5.52	1200 (33.98)	1730 (48.99)	2000 (56.63)					
100	6.89	1600 (45.31)	1900 (53.80)	2400 (67.96)					
125	8.62	2100 (59.47)	2500 (70.79)	3300 (93.45)					

Capacity Table (2% Droop) - Models N, R

Capacities in scfh (m ³ /hr) - Orifice Size									
Inlet Pressure		1/8"	1/8 x 3/16"	3/16"	1/4"	5/16"	3/8"	1/2"	1/2 x 9/16"
PSIG	Bar	3.2 mm	3.2 x 4.8 mm	4.8 mm	6.4 mm	7.9 mm	9.5 mm	12.7 mm	12.7 x 14.3 mm
3	0.21	130 (3.68)	150 (4.25)	240 (6.80)	320 (9.06)	450 (12.74)	490 (13.88)	560 (15.86)	645 (18.26)
5	0.34	180 (5.10)	255 (7.22)	340 (9.63)	460 (13.03)	680 (19.26)	730 (20.67)	925 (26.19)	1085 (30.72)
10	0.69	320 (9.06)	420 (11.89)	600 (16.99)	850 (24.07)	1240 (35.11)	1280 (36.25)	1540 (43.61)	1710 (48.42)
15	1.03	440 (12.46)	530 (15.01)	850 (24.07)	1150 (32.56)	1600 (45.31)	1600 (45.31)	Orifice Inlet Pressure Rating Exceeded	
20	1.38	530 (15.01)	590 (16.71)	1040 (29.45)	1420 (40.21)	2000 (56.63)	2000 (56.63)		
30	2.07	710 (20.10)	770 (21.80)	1430 (40.49)	1920 (54.37)	2400 (67.96)			
40	2.76	875 (24.78)	930 (26.33)	1700 (48.14)	2390 (67.68)				
50	3.45	1050 (29.73)	1140 (32.28)	2100 (59.47)	2800 (79.29)				
60	4.14	1200 (33.98)	1300 (36.81)	2400 (67.96)	3130 (88.63)				
80	5.52	1500 (42.48)	1825 (51.68)	2700 (76.46)					
100	6.89	1850 (52.39)	1950 (55.22)	3000 (84.95)					
125	8.62	2100 (59.47)	2600 (73.62)	3500 (99.11)					

Inlet Effect ^B	0.01 PSIG	0.01 PSIG	0.02 PSIG	0.03 PSIG	0.03 PSIG	0.04 PSIG	0.06 PSIG	0.06 PSIG
Lock Up ^C	0.06 PSIG	0.06 PSIG	0.08 PSIG	0.09 PSIG	0.10 PSIG	0.12 PSIG	0.14 PSIG	0.14 PSIG

Note:
^B- Change in outlet pressure for 10 PSIG inlet pressure change
^C- Outlet pressure increase required for lock up

2 PSIG (0.14 bar) - B42 Residential Regulator - Models N, R

Typical Performance Curves

Manufacturer.....Actaris

Type and Model.....B42 R

Regulator:

Inlet Size3/4" NPT

Outlet Size.....1" NPT

Orifice Size3/16"

SpringYellow/Black

.....(p/n 762650)

Set Point 2 PSIG with 10 psig inlet @ 50 scfh. All test results are reported at a base of 14.7 psia and 60 F.

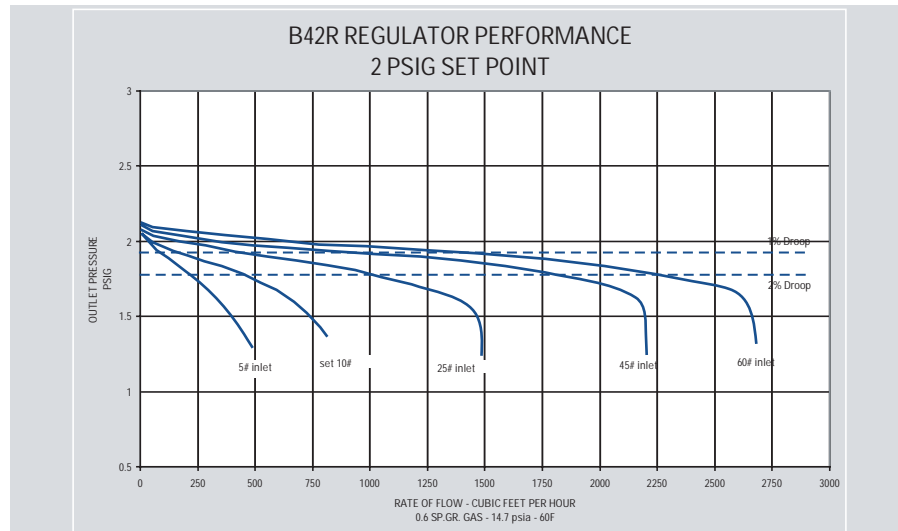

Relief Characteristic Curves R Model Only

Manufacturer.....Actaris

Type and Model.....B42 R

Regulator:

Inlet Size3/4" NPT

Outlet Size.....1" NPT

Vent Size1" NPT

Set Point 2 PSIG with 10 psig inlet @ 50 scfh. All test results are reported at a base of 14.7 psia and 60 F.

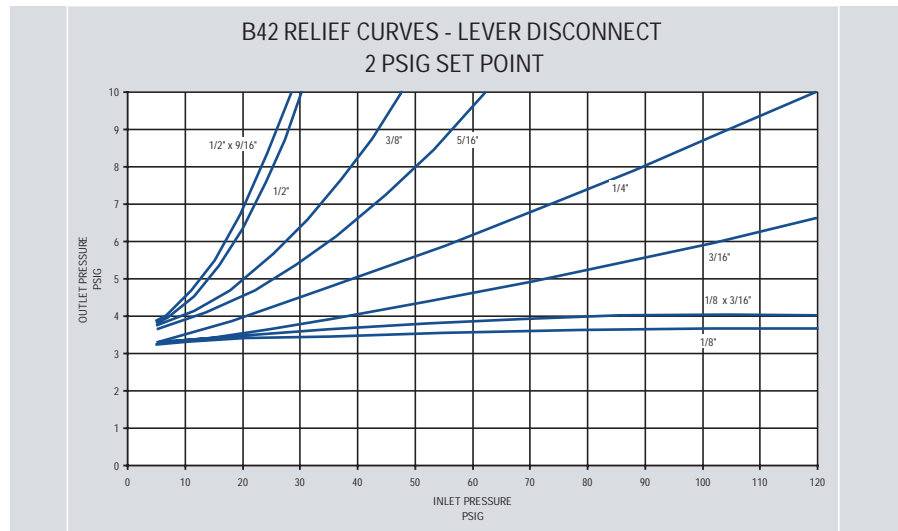

5 PSIG (0.34 bar) - B42 Residential Regulator Capacity Table (1% Droop) - Models N, R

White Spring (762647)
Position 5
1" NPT Outlet

Inlet Pressure		Capacities in scfh (m ³ /hr) - Orifice Size					
PSIG	Bar	1/8" 3.2 mm	3/16" 4.8 mm	1/4" 6.4 mm	5/16" 7.9 mm	3/8" 9.5 mm	1/2" 12.7 mm
10	0.69	175 (4.96)	240 (6.80)	300 (8.50)	355 (10.05)	420 (11.89)	610 (17.27)
15	1.03	130 (3.68)	160 (4.53)	225 (6.37)	275 (7.79)	320 (9.06)	
20	1.38	160 (4.53)	195 (5.52)	260 (7.36)	305 (8.64)	380 (10.76)	
30	2.07	190 (5.38)	255 (7.22)	315 (8.92)	400 (11.33)		
40	2.76	220 (6.23)	270 (7.65)	390 (11.04)			
50	3.45	255 (7.22)	300 (8.50)	450 (12.74)			
60	4.14	275 (7.79)	390 (11.04)	550 (15.57)			
80	5.52	349 (9.86)	478 (13.50)				
100	6.89	422 (11.92)	579 (16.36)				
125	8.62	514 (14.52)	705 (19.92)				

Orifice Inlet Pressure Rating Exceeded

Capacity Table (2% Droop) - Models N, R

Inlet Pressure		Capacities in scfh (m ³ /hr) - Orifice Size					
PSIG	Bar	1/8" 3.2 mm	3/16" 4.8 mm	1/4" 6.4 mm	5/16" 7.9 mm	3/8" 9.5 mm	1/2" 12.7 mm
10	0.69	175 (4.96)	240 (6.80)	300 (8.50)	355 (10.05)	420 (11.89)	610 (17.27)
15	1.03	230 (6.51)	365 (10.34)	430 (12.18)	555 (15.72)	650 (18.41)	
20	1.38	255 (7.22)	445 (12.60)	525 (14.87)	650 (18.41)	770 (21.80)	
30	2.07	370 (10.48)	570 (16.14)	710 (20.10)	950 (26.90)		
40	2.76	405 (11.47)	745 (21.10)	940 (26.62)			
50	3.45	445 (12.60)	855 (24.21)	1160 (32.85)			
60	4.14	535 (15.15)	925 (26.13)	1450 (41.06)			
80	5.52	714 (20.17)	1003 (28.33)				
100	6.89	865 (24.44)	1215 (34.32)				
125	8.62	1054 (29.77)	1480 (41.81)				

Orifice Inlet Pressure Rating Exceeded

Inlet Effect ^B	0.05 PSIG	0.08 PSIG	0.10 PSIG	0.12 PSIG	0.14 PSIG	0.20 PSIG	
Lock Up ^C	0.08 PSIG	0.10 PSIG	0.11 PSIG	0.12 PSIG	0.14 PSIG	0.16 PSIG	

Note:
B- Change in outlet pressure for 10 PSIG inlet pressure change
C- Outlet pressure increase required for lock up

5 PSIG (0.34 bar) - B42 Residential Regulator - Models N, R

Typical Performance Curves

Manufacturer.....Actaris
 Type and Model.....B42 R
 Regulator:
 Inlet Size3/4" NPT
 Outlet Size.....1" NPT
 Orifice Size3/16"
 SpringWhite (p/n 762137)
 Set Point 5 PSIG with 10 psig inlet @ 50 scfh. All test results are reported at a base of 14.7 psia and 60 F.

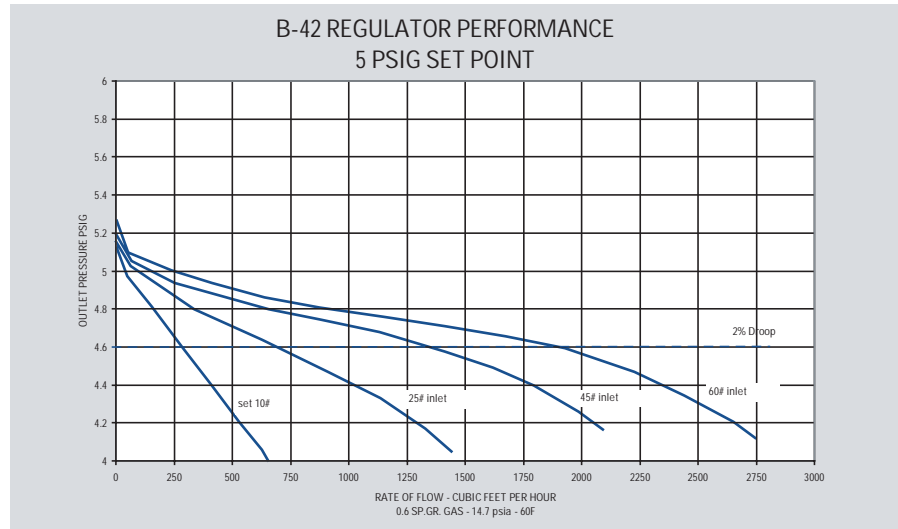

Relief Characteristic Curves R Model Only

Manufacturer.....Actaris
 Type and Model.....B42 R
 Regulator:
 Inlet Size3/4" NPT
 Outlet Size.....1" NPT
 Vent Size1" NPT
 Set Point 5 PSIG with 10 psig inlet @ 50 scfh. All test results are reported at a base of 14.7 psia and 60 F.

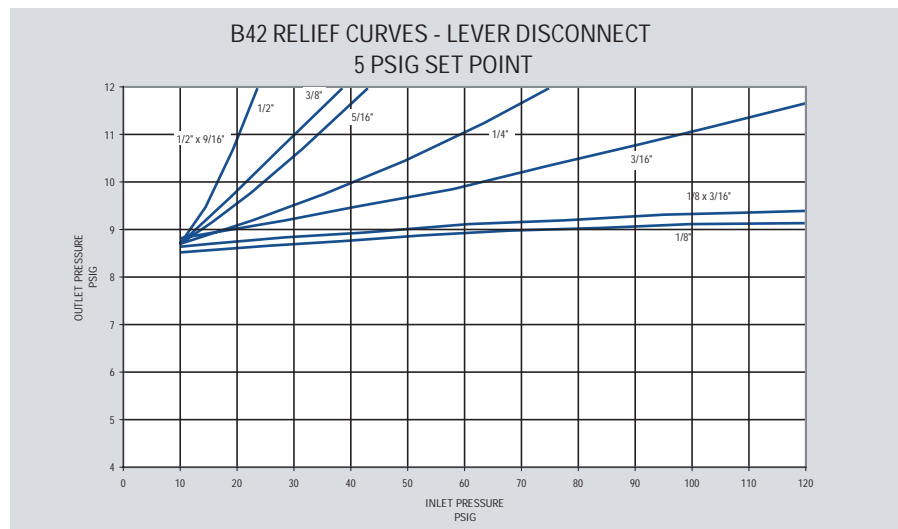

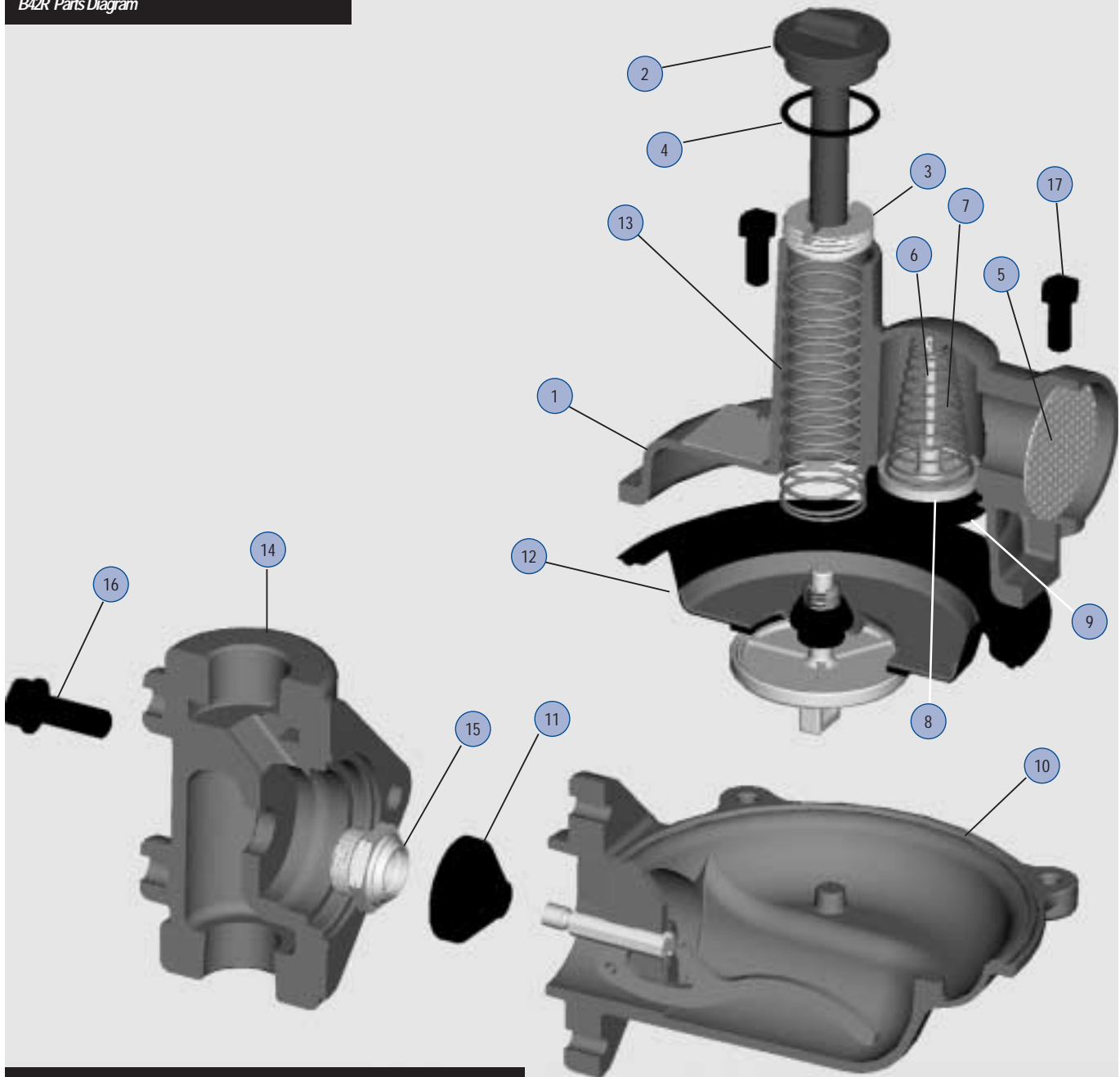

Operating Principle

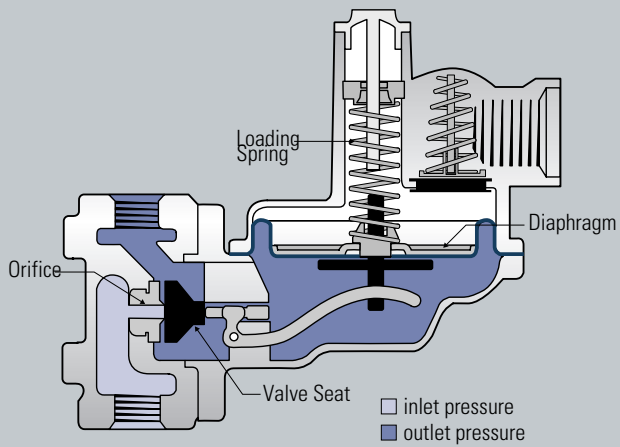

NO.	PART#	QTY		DESCRIPTION
		N	R	
1		1	1	Upper Diaphragm Case
	753443			Std. 1" Vent
	753442			Std. ¾" Vent
	753445			HP. 1" Vent
	753444			HP. ¾" Vent
2		1	1	Seal Cap
	760260			Seal Cap - Gray
	760261			Seal Cap - Red
	760262			Seal Cap - Green
3	760215	1	1	Adjustment Screw - Std
	760217	1	1	Adjustment Screw - HP
4	765501	1	1	Seal Cap Gasket
5	762933	1	1	Vent Screen
6	754834	1	1	Vent Valve Disc Pin
7	762651	1	1	Vent Valve Spring
8	765181	1	1	Vent Valve Disc
9	765685	1	1	Vent Valve Seat
10	715075	1	1	Lower Diaphragm Case Assembly
11		1	1	Valve Seat
	765051			Valve Seat - Standard
	765053			Valve Seat - Silicone
				Diaphragm Assembly Complete
12	720085		1	Diaphragm - Standard Relief (R)
	720091	1		Diaphragm - Non-Relief (N)
	761005	1	1	Upper Diaphragm Plate
	75606102		1	Lower Diaphragm Plate (R)
	75606103	1		Lower Diaphragm Plate (N)
	761401		1	Relief Spring Retaining Clip
	755513	1		Nut (N)
	755801	1		Washer (N)
	762653		1	Relief Spring - 7" W.C. - Std.
	762655			Relief Spring - 5" W.C.
	754911	1	1	Stop Stem Guide Bushing
13		1	1	Adjustment Springs - Specify Color
	762649			5-7" W.C. Green
	762645			6-8" W.C. Brown
	762646			8-14" W.C. Blue
	762647			12-28 W.C Silver
	762650			1-2 PSIG Yellow/Black
	762131			2-4 PSIG Yellow* (HP)
	762137			4-5 PSIG White* (HP)
14		1	1	Valve Body - Specify Type and Size
				Straight
	750586			1/2" x 1/2" NPT
	750587			1/2" x 1/2" NPT w/ 1/8" In. PP
	750588			1/2" x 1/2" NPT w/ 1/8" Out. PP
	750527			¾" x ¾" NPT
	750528			¾" x ¾" NPT w/ 1/8" In. PP
	750529			¾" x ¾" NPT w/ 1/8" Out. PP
	750530			¾" x ¾" NPT w/ In/Out PP
	750531			¾" x 1" NPT
	750532			¾" x 1" NPT w/ 1/8" In. PP

NO.	PART#	QTY		DESCRIPTION
		N	R	
	750533			¾" x 1" NPT w/ 1/8" Out. PP
	750534			¾" x 1" NPT w/ In/Out PP
	750567			¾" x 1-1/4" NPT
	750568			¾" x 1-1/4" NPT w/ 1/8" In. PP
	750569			¾" x 1-1/4" NPT w/ 1/8" Out. PP
	750535			1" x 1" NPT
	750536			1" x 1" NPT w/ 1/8" In. PP
	750537			1" x 1" NPT w/ 1/8" Out. PP
	750538			1" x 1" NPT w/ In/Out PP
	750570			1" x 1-1/4" NPT
	750571			1" x 1-1/4" NPT w/ 1/8" In. PP
	750572			1" x 1-1/4" NPT w/ 1/8" Out. PP
	750573			1-1/4" x 1-1/4" NPT
	750574			1-1/4" x 1-1/4" NPT w/ 1/8" In. PP
	750575			1-1/4" x 1-1/4" NPT w/ 1/8" Out. PP
				90° Angle Body
	750541			¾" x ¾" NPT
	750542			¾" x ¾" NPT w/ 1/8" In. PP
	750543			¾" x 1" NPT
	750544			¾" x 1" NPT w/ 1/8" In. PP
	750545			1" x 1" NPT
	750546			1" x 1" NPT w/ In/Out PP Plug
				Compact - Bottom Rear Entry
	750576			¾" x ¾" NPT
	750578			¾" x ¾" NPT w/ 1/8" In. PP
	750577			¾" x 1" NPT
	750579			¾" x 1" NPT w/ 1/8" In. PP
15		1	1	Orifice - Specify size
	757611			1/8" - Aluminum
	757641			1/8" - Brass
	757651			1/8" x 3/16" - Aluminum
	757619			3/16" - Aluminum
	757643			3/16" - Brass
	757623			1/4" - Aluminum
	757645			1/4" - Brass
	757627			5/16" - Aluminum
	757631			3/8" - Aluminum
	757453			1/2" - Aluminum
	75767101			1/2" x 9/16" - Aluminum
	769417	1	1	Legal Warning Label
16	8006701	2	2	Valve Body Screw 5/16 - 18 x 7/8 LG.
17	010323	4	4	Case Screw ¼ - 20 x ¾ LG.
	765605	1	1	Valve Body Gasket

NO.	PART#	DESCRIPTION
	799051	Adjustment Tool

NO.	PART#	TORQUE SPECIFICATIONS
	010322	Case Screws: 35 - 45 in. lb.
	765605	Valve Body Screws: 85 - 115 in. lb
	see above	Orifice: 450 - 600 in. lb.

Installation

- A. Make certain all shipping plugs are removed from the inlet, outlet and vent of any regulator before installation.
- B. When installing the regulator, the inside of the piping and the regulator inlet and outlet are to be clean, free of dirt, pipe dope and other debris to prevent entry into the regulator which could cause loss of pressure control.
- C. The pipe joint sealant should be applied on the male threads of the pipe. Do not use any pipe joint material on the female threads of the regulator or it could become lodged in the regulator causing possible loss of pressure control.
- D. Gas must flow through the valve body of the regulator in the same direction as the arrow cast on the body, or the outlet side of the regulator may be overpressured and damaged.
- E. The diaphragm casing may be mounted in any position relative to the body through a full 360 angle.
- F. When the regulator is installed OUTDOORS, the vent must always be positioned so that rain, snow, moisture or foreign particles cannot enter the vent opening. It is recommended that the vent be positioned to face downward so as to avoid entry of water or other matter which could interfere with the proper operation of the regulator. The vent should be located away from building eaves, window openings, building air intakes and above the expected snow level at the site. The vent opening should be inspected periodically to insure it does not become blocked by foreign material.
- G. When the regulator is installed INDOORS, the vent must be piped to the outside atmosphere while using the shortest length of pipe, the least number of elbows, and having as large a pipe diameter as the vent size or

larger. USING VENT PIPE ANY SIZE SMALLER THAN THE VENT CONNECTION WILL LIMIT THE REGULATOR S INTERNAL RELIEF VALVE CAPACITY. The outlet end of the pipe must be protected from moisture and the entrance of foreign particles. The regulator should be specified by the user with the size vent and pipe threads desired to make the vent pipe connection.

START-UP PROCEDURE

- A. A pressure gauge should be mounted downstream of the regulator to monitor the downstream pressure.
- B. With the downstream valve closed, slowly open the inlet valve. The outlet pressure should rise to slightly greater than the set-point.
- C. Be sure there are no leaks and all connections are tight.
- D. The regulator has been preset at the factory to match specifications given when it was ordered. The outlet pressure may be adjusted by removing the seal cap on top of the spring housing and adjusting the ferrule or screw inside the spring housing using a ratchet with a socket and an extension. With a small amount of gas flowing through the regulator, rotate the ferrule clock-wise to raise the outlet pressure and counter-clockwise to lower the outlet pressure.
- E. After the desired outlet pressure is achieved, replace the seal cap, recheck for leaks. The regulator is ready for operation.

SAFETY NOTES:

- A. The maximum inlet pressure for this regulator is dependent upon the size of the orifice and model designation. The non-relief models are limited to 60 psig maximum inlet pressure unless additional safety devices are used as

outlined in DOT code, OPS, Part 192, section 192.197.

- B. When these models are used on liquid petroleum gases, they should be restricted to second-stage pressure reduction in the gaseous phase.

SAFETY WARNING:

This product, as of the date of manufacture, is designed and tested to conform to all governmental or industry safety standards then existing as may apply to the manufacturer.

The purchaser and user of this product are warned that compliance with the manufacturer s instructions and procedures is required in order to avoid the hazards of leaking gas resulting from improper installation, start-up or use of this product, and further, that all area fire control, building codes or other safety regulations established under public laws which regulate or concern the application, installation, operation or general use of this product should be complied with.

In order to insure the safe and proper operation of this product, the manufacturer recommends that this product be installed by a qualified installer.

Page Left Intentionally Blank

Ordering Information

Specify:

- 1 Inlet and Outlet Connection Size and Type
- 2 Model Number
- 3 Outlet pressure desired
- 4 Inlet pressure range
- 5 Type of gas and maximum capacity required
- 6 Assembly position number (see chart at right)
- 7 Vent size
- 8 Special requirements such as tagging, 1/8" pipe plug tap, seal wire, etc.

Assembly Positions

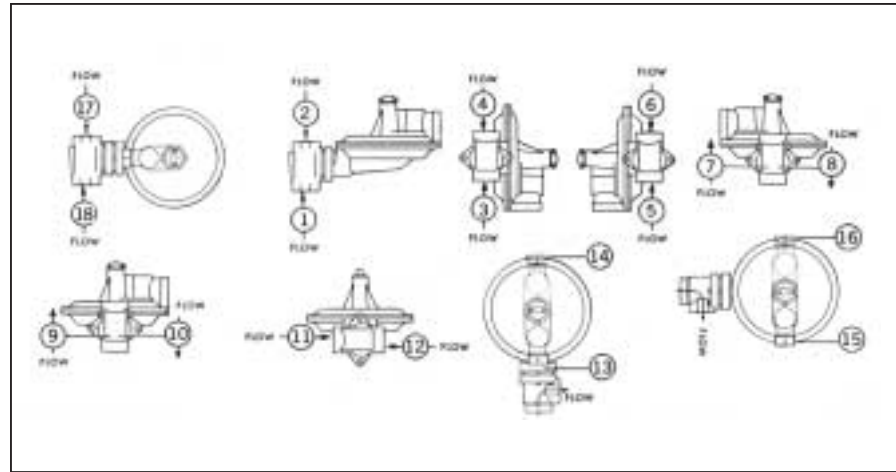

Warranty

Actaris Metering System, 970 Highway 127 North, Owenton, Kentucky 40359-9802, warrants this gas product against defects in materials and workmanship for the earlier of one (1) year from the date the product is shipped by Actaris or a period of one year from the date the product is installed by Actaris at the original purchaser's site. During such one-year period, provided that the original purchaser continues to own the product, Actaris will, at its sole option, repair any defects, replace the product or repay the purchase price.

This warranty will be void if the purchaser fails to observe the procedures for installation, operation or service of the product as set forth in the Operating Manual and Specifications for the product or if the defect is caused by tampering, physical abuse or misuse of the product.

Actaris specifically disclaims all implied warranties including those of merchantability or of fitness for a particular purpose. Under no circumstances will Actaris be liable for incidental or consequential

damages of any kind whatsoever.

Actaris liability for any claim of any kind, including negligence and breach of warranty for the sale and use of any product covered by or furnished, shall in no case exceed the price allocable to the product or part thereof which gives rise to the claim.

In the event of a malfunction of the product, consult your Actaris Service Representative or Actaris Metering Systems, 970 Highway 127 North, Owenton, Kentucky 40359-9802.

Reference Information

Regulator Pressure Ratings - JOT-2

Regulator Startup - #769402

Istec Corporation
5 Park Lake Road
Sparta, NJ 07871
Tel. (973) 383-9888 Fax. (973) 383-9088

