

W22

Three-Phase Electric Motor

**NEMA Technical
Catalog**

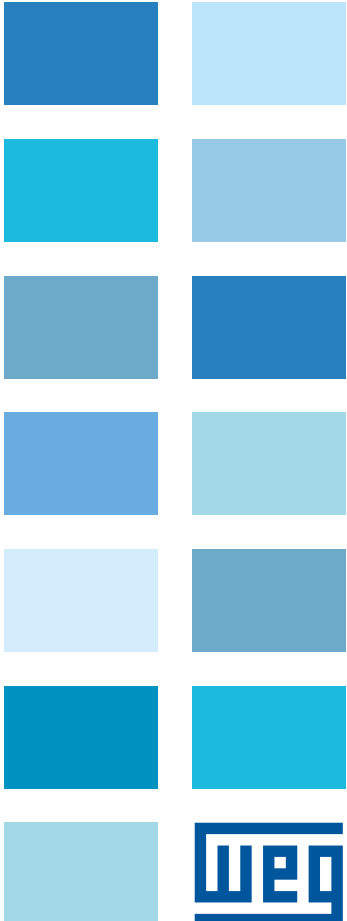

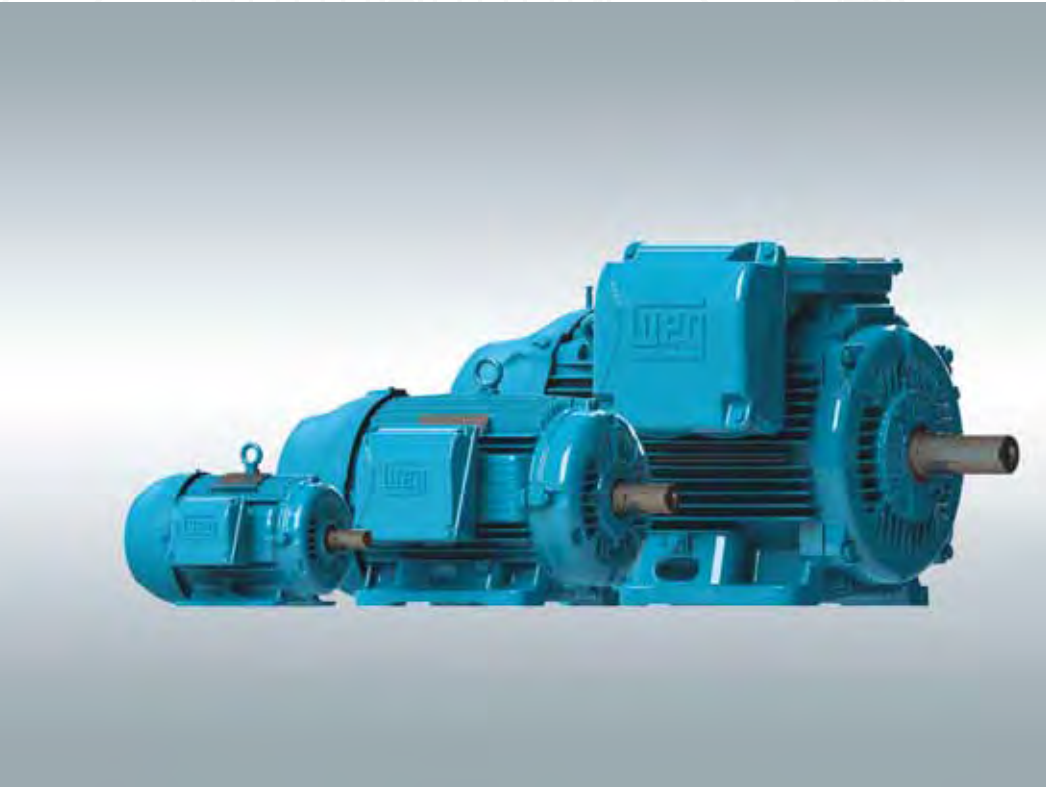

W22 Line

The increasing demand for electrical energy to sustain global development requires consistent heavy investments in power supply generation. However, in addition to complex medium and long term planning, these investments rely on natural resources, which are becoming depleted due to constant pressures upon the environment. The best strategy, therefore, to maintain energy supply in the short term is to avoid wastage and increase energy efficiency. Electric motors play a major role in this strategy; since around 40% of global energy demand is estimated to be related to electric motor applications. Consequently, any initiatives to increase energy efficiency, by using high efficiency electric motors and frequency inverters, are to be welcomed, as they can make a real contribution to reductions in global energy demand.

At the same time as efficiency initiatives make an impact in traditional market sectors, the application of new technologies in emerging sectors is resulting in profound changes in the way that electric motors are applied and controlled. By integrating these changes

together with the demands for increased energy efficiency, WEG has taken up the challenge and produced a new design of high efficiency motor; one that exceeds the performance of WEG's existing W21 motor line, which is recognised worldwide for its quality, reliability and efficiency.

Using the latest generation of computerised tools, such as structural analysis software (finite element analysis) and computer fluid dynamics, as well as electrical design optimisation software, an innovative – next generation - product has been developed: the W22 motor.

Several key objectives have been achieved in the design of the W22 motor:

- Reduction of noise and vibration levels
- Increased energy efficiency and reduced thermal footprint
- Easy maintenance
- Compatibility with present & future generations of frequency inverters
- Flexible and modular design



Reducing carbon footprint and cutting costs with the W22

W22 range of three-phase induction motors, designed to offer not only significantly lower energy consumption, but lower noise and vibration, higher reliability, easier maintenance and lower cost of ownership.

Consisting of three products, each designed to exceed the requirements of the NEMA MG 1-2009, the W22 Super Premium Efficiency, NEMA Premium Efficiency and High Efficiency can reduce energy losses by between 10% and 50% compared with other typical motors. It's an extremely effective way to reduce your carbon footprint, as well as your energy costs.

W22 motors fully comply with the energy efficiency requirements of the EISA 2007 (Energy Independence and Security Act 2007) from USA and EcoAction from Canada. For more information regarding global efficiency regulations, potential reduction in CO₂ emissions and return on investment of W22 motors, please visit www.weg.net/green.

Visual Index

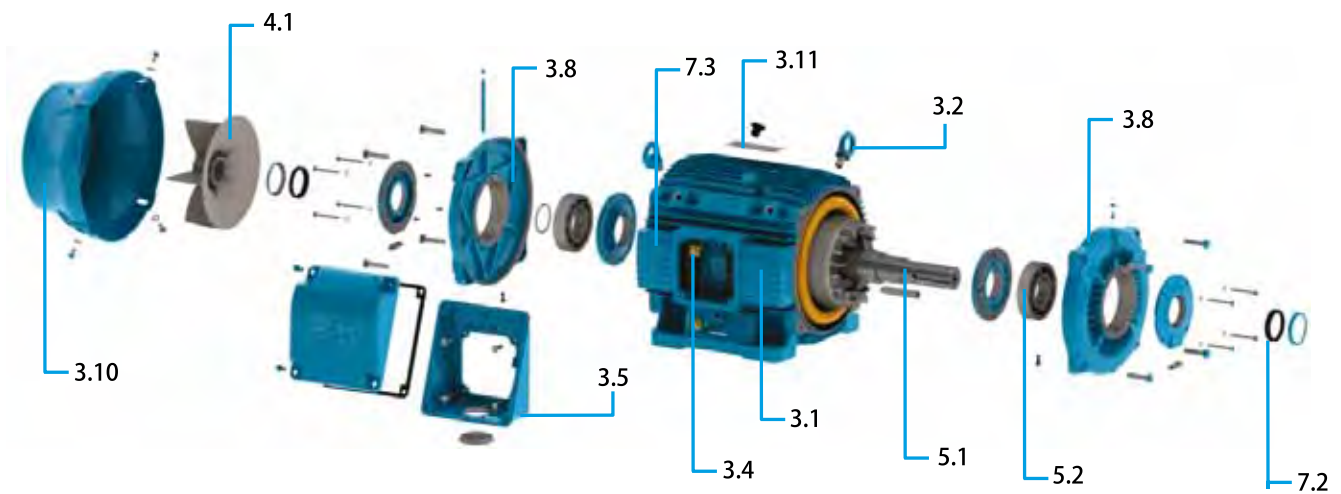

3.1	Frame	Page 6
3.2	Eyebolts	Page 6
3.4	Earth terminals	Page 7
3.5	Terminal box	Page 7
3.8	Endshields	Page 9
3.10	Fan cover	Page 9
3.11	Nameplate	Page 9
4.1	Cooling system	Page 10
5.1	Shaft	Page 11
5.2	Bearings	Page 11
7.2	Sealing system	Page 13
7.3	Painting	Page 13

Table 1 - Visual Index

Table of Contents

- 1. Versions available 6
- 2. Standards 6
- 3. Construction details 6
 - 3.1 Frame..... 6
 - 3.2 Eyebolts..... 6
 - 3.3 Points for vibration monitoring 6
 - 3.4 Earth terminals..... 7
 - 3.5 Terminal box 7
 - 3.6 Power supply connection leads 8
 - 3.7 Accessory connection leads 8
 - 3.8 Endshields 8
 - 3.9 Drains 8
 - 3.10 Fan cover 9
 - 3.11 Nameplate..... 9
- 4. Cooling system and Noise level / Vibration level / Impact resistance 10
 - 4.1 Cooling system and Noise Level..... 10
 - 4.2 Vibration level..... 10
 - 4.3 Impact resistance..... 10
- 5. Shaft / Bearings 11
 - 5.1 Shaft..... 11
 - 5.2 Bearings 11
 - 5.2.1 Permissible loads..... 12
 - 5.2.2 Bearing monitoring 12
- 6. Mounting forms..... 13
- 7. Degree of protection / Sealing system / Painting 13
 - 7.1 Degree of protection 13
 - 7.2 Sealing system..... 13
 - 7.3 Painting 13
 - 7.3.1 Internal anti-corrosive painting 14
- 8. Voltage / Frequency 14
- 9. Ambient / Insulation 14
 - 9.1 Space heaters..... 14
- 10. Motor protection..... 15
 - 10.1 Protection based on operating temperature 15
 - 10.2 Protection based on operating current..... 15
- 11. Variable speed drive application 16
 - 11.1 Considerations regarding rated voltage 16
 - 11.2 Torque restrictions on variable speed drive applications 16
 - 11.3 Restrictions regarding current flow through the bearings 16
 - 11.4 Forced ventilation kit..... 17
 - 11.5 Encoders..... 17
- 12. Construction features..... 18
- 13. Optional features 20
- 14. Electrical data 24
- 15. Mechanical data 32
- 16. Terminal box drawings..... 35
- 17. Drip cover data 36
- 18. Distance from fan cover to wall..... 36
- 19. Packaging..... 37
- 20. Spare parts 38



1. Versions available

W22 NEMA Motors are available in three versions: W22 High Efficiency, NEMA Premium Efficiency and Super Premium Efficiency. These versions are in accordance with the tables 12-11 and 12-12 from NEMA MG-1.

2. Standards

W22 motors meet the requirements and regulations of the latest version of the following Standards:

- CSA C22.2 No. 100-04 – Motor and Generators
- CSA C390 – Test Methods, Marking Requirements and Energy Efficiency Levels for Three-Phase Induction Motors
- IEEE STD 112 – IEEE Standard Test Procedure for Polyphase Induction Motors and Generators
- NEMA MG-1 – Motors and Generators
- UL 1004-1 - Rotating Electrical Machines – General Requirements

3. Construction details

The information included in this document refers to standard construction features and the most common variations for W22 motors in low voltage for general applications in frame sizes from 143T to 588/9T.

W22 motors for special and/or customised applications are available on request. For more information, please contact your WEG office or distributor.

3.1 Frame

The W22 frame (figure 1) is manufactured in FC-200 cast iron to provide high levels of mechanical strength to cater for the most critical applications. The cooling fins are designed to minimize the accumulation of liquids and dust over the motor.



Figure 1 – W22 Frame

The motor feet are completely solid for better mechanical strength (figure 2), allowing easier alignment and installation.

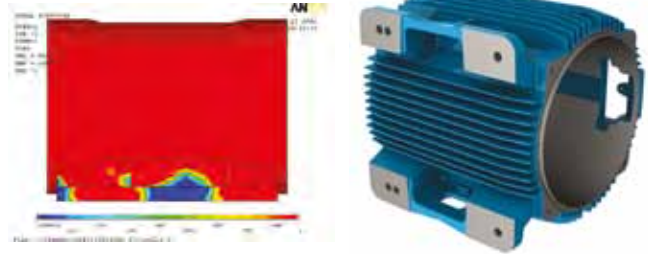

Figure 2 – Solid feet

3.2 Eyebolts

Eyebolts are available from frame size 182T. The position of the eyebolts are shown in the table 2:

Number of eyebolts	Description
1	Frames 182T to 326T Motors with feet and with side mounted terminal box
2	Frames 182T to 444/5T Motors with feet and with top mounted terminal box
2	Frames 182T to 444/5T – Motors without feet and with C or D flange
2	Frames 445/7T to 588/9T – Motors with feet and side or top mounted terminal box. These motors have four threaded holes in the upper part of the frame for fastening of the eyebolts (figure 3)
2	Frames 445/7T to 588/9T – Motors without feet and with C or D flange. These motors have four threaded holes in the upper part of the frame for fastening of the eyebolts and two more threaded holes in the bottom part

Table 2: Eyebolts



Figure 3: Motor with four threaded holes for fastening of the eyebolts

3.3 Points for vibration monitoring

To allow easy maintenance, specifically vibration testing, the 254T to 588/9T frames are designed with flat areas on both ends for better placement of the accelerometer (figure 4). These areas are available both in vertical and horizontal planes. Besides areas on the frame, W22 motors count on flat areas on the endshields for easier installation of accelerometers.

As an option M8 threads for SPM accelerometers can be supplied.

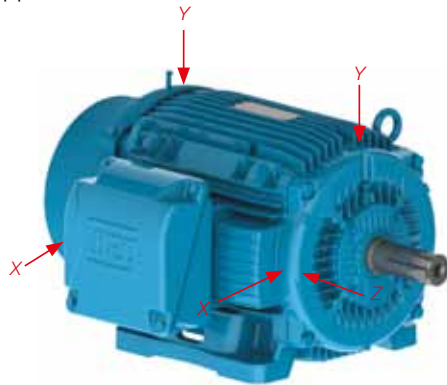

Figure 4 - Flat surfaces for vibration monitoring on the back and front side

3.4 Earth terminals

All frames from 143T to 588/9T are provided with earth terminals located inside and adjacent to the terminal box (see figure 5).

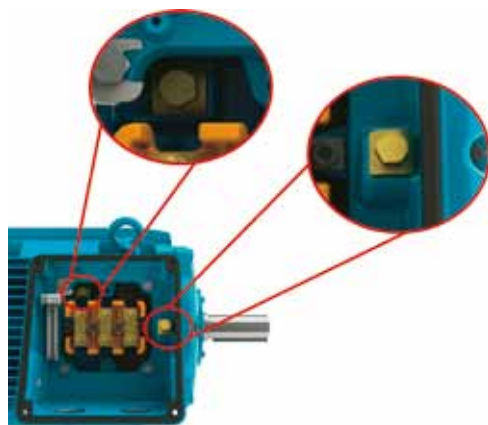

Figure 5 - Earth terminals in the terminal box

The frames 364/5T to 444/5T are also fitted with a provision to an additional earth terminal be mounted in the same side of the terminal box.

For frames sizes 445/7T to 588/9T, the enclosures are provided with two external earth terminals, being the provision also fitted with an earth terminal (figure 6).

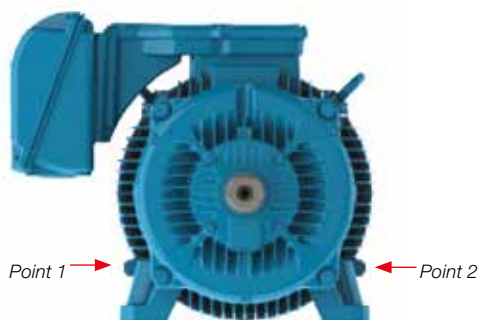

Figure 6 - Earth terminals position in the frame

3.5 Terminal box

The terminal box of W22 motors is made with FC-200 cast iron, which is the same material used to produce the frame and endshields. It is diagonally split for easier handling of leads and connections.

It is possible to supply 588/9T motors with an oversized terminal box. In this case, the aspect of the motor with side and top mounted terminal box is shown in the figures 7.1 and 7.2.



Figure 7.1 and 7.2 - Frame size 588/9T with oversized terminal box

For frame sizes 445/7T to 588/9T the terminal box is positioned towards the drive end of the motor. This arrangement allows improvement of the airflow over the cooling fins, thus reducing motor operating temperatures. Terminal box position on either the left or right hand side of the motor is possible through the use of an adaptor (see figure 8).

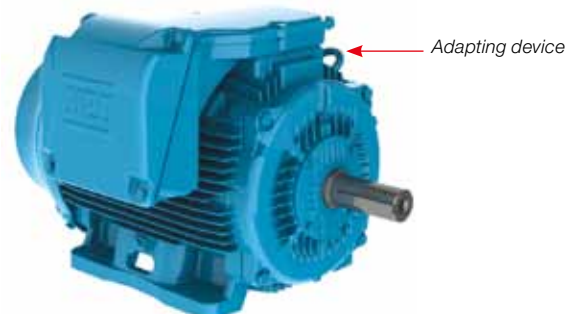

Figure 8 - Terminal box mounted on the left side viewing from shaft end

When supplied from the factory with a side mounted terminal box arrangement, this can be positioned on the opposite side simply by rotating the adaptor. Similarly, by removing the adaptor and adjusting the length of the motor leads, the terminal box can be positioned on top of the motor.

The flexibility of terminal box positions on the W22 motor offered by the adaptor can be seen in figure 9.



Figure 9 - Terminal box mounted on both sides and on top (versatility)

Conversely, factory supplied motors with the terminal box position on top can be modified to side mounting by fitting the adaptor and extending the motor leads.

For the frame size range 143T to 444/5T the terminal box position is centralized on the motor frame and can be supplied in two configurations – left/ right side (standard) or top (optional) and for changing the mounting (terminal box position), the motor must be disassembled.

Please Note: For all terminal box position modifications please contact WEG or your local WEG service centre. For all frames, the terminal box can be rotated in 90° increments. Motors in frame sizes 586/7T and 588/9T are supplied with removable cast iron cable gland plates. As an option, the gland plates can be supplied undrilled. Motors are supplied with plastic plugs in the cable entries to maintain the degree of protection during transport and storage.

In order to guarantee the degree of protection, cable entries must comply with at least the same degree of protection indicated on the motor nameplate. Lack of compliance with such detail can invalidate the motor warranty. If required, please contact the WEG Service Area for further advice.

3.6 Power supply connection leads

Motor power supply leads are marked in accordance with NEMA MG-1 Part 2 – Terminal markings and, as optional, can be fitted with a terminal block made from a polyester based resin BMC (Bulk Moulding Compound), duly reinforced with fibre glass (see figure 10).



Figure 10: Six-pin terminal block

Motors 588/9T can be provided with the terminal block as shown in the figure 11.



Figure 11: 588/9T terminal block

3.7 Accessory connection leads

Accessory terminals are assembled on connectors whenever the motor is supplied with a terminal block. They may be assembled inside the main power terminal box or in a separate accessory terminal box (figure 12).

Whether the accessory terminals are assembled inside the main power or a separate terminal box, an NPT 3/4" threaded hole is provided for fitting of cable glands for the incoming connection leads.

In the Mechanical Data section of this catalogue it is possible to check the quantity of connectors that may be assembled inside the main power and accessory terminal boxes.



Figure 12: Accessory terminal box attached to power terminal box

For frames 213T to 588/9T, there is also the option of providing a dedicated terminal box for the connection of space heaters as shown in figure 13.



Figure 13: Two accessory terminal boxes attached to power terminal box

3.8 Endshields

The drive end endshield (figure 14) is designed with fins for better thermal heat dissipation, and to ensure low bearing operating temperatures, resulting in extended lubrication intervals.

For the frames 364/5T to 588/9T, where ventilation is critical for thermal performance of the motor, the endshield fastening screws are placed in such a way so as not to block airflow to any fin, thus contributing to better thermal exchange.



Figure 14 – Drive and non-drive endshields

3.9 Drains

The endshields have holes for drainage of water that may condense inside of the frame. These holes are supplied with rubber drain plugs, in accordance with figure 17 for frame range 254T to 588/9T. These plugs leave the factory in the closed position and must be opened periodically to allow the exit of condensed water. In the 143T to 215T frame range, plugs are automatic and made of plastic.



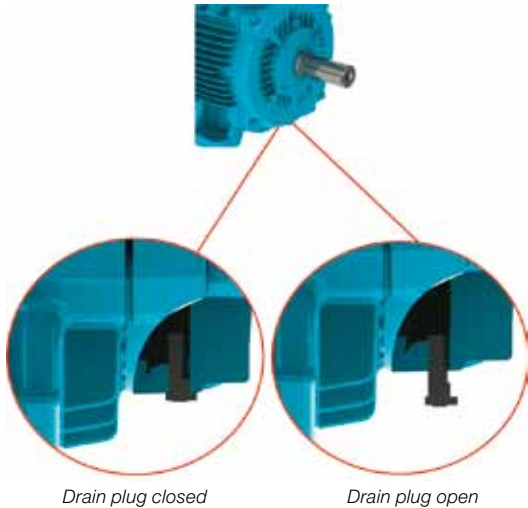

Figure 15: Detail of the drain plug position on drive endshield (254T-588/9T)

3.10 Fan cover

The fan cover is made of steel for frames 143T to 215T and FC-200 cast iron for frames 254T to 588/9T. The cast iron fan covers have an aerodynamic design, which results in a significant reduction in noise level and optimized airflow between frame fins for heat exchange improvement. Figure 16 shows the aerodynamic design of the cast iron fan cover.



Figure 16 – Fan cover

3.11 Nameplate

The nameplate supplies information determining motor construction and performance characteristics. The line name is given on the first line of the nameplate together with nominal efficiency levels as required by NEMA MG-1.



Figure 17 – Nameplate position of W22 motors

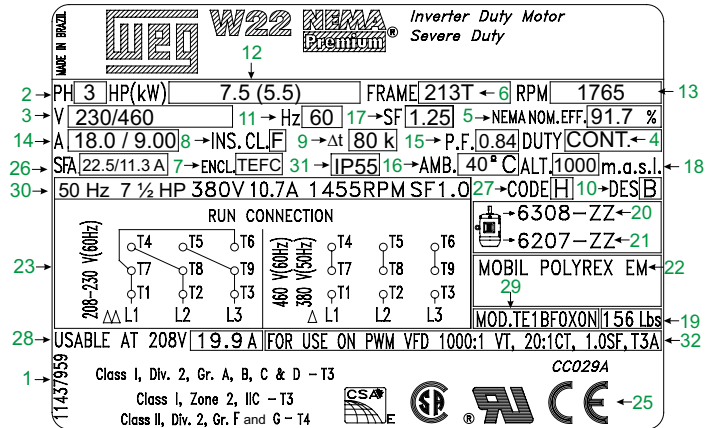

Figure 18 - Nameplate layout for frames 143T to 215T

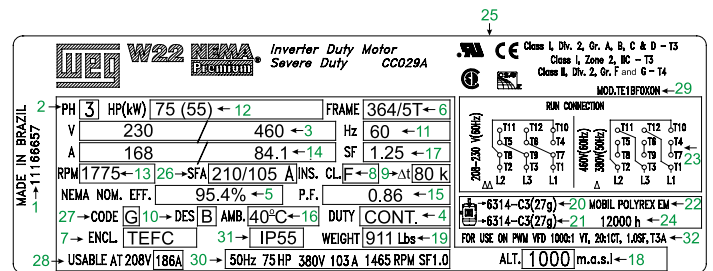

Figure 19 - Nameplate layout for frames 254T to 588/9T

- 1 – Motor code
- 2 – Three phase
- 3 – Rated operating voltage
- 4 – Service duty
- 5 – Efficiency
- 6 – Frame size
- 7 – Enclosure
- 8 – Insulation class
- 9 - Temperature rise
- 10 – Design
- 11 – Frequency
- 12 – Motor rated power
- 13 – Full load speed (rpm)
- 14 – Rated operating current
- 15 – Power factor
- 16 – Ambient temperature
- 17 – Service factor
- 18 – Altitude
- 19 – Motor weight
- 20 – Drive end bearing specification and amount of grease
- 21 – Non-drive end bearing specification and amount of grease
- 22 – Type of grease for bearings
- 23 – Connection diagram
- 24 – Relubrication intervals in hours
- 25 – Certification labels
- 26 - Service factor current
- 27 - NEMA code letters for locked-rotor kVA
- 28 - Current at 208 V
- 29 - Model
- 30 - Derating 50 Hz
- 31 - Degree of protection
- 32 - VFD supply

4. Cooling system and Noise level / Vibration level / Impact resistance

4.1 Cooling system and Noise level

The W22 standard motors are totally enclosed fan cooled (IC411), as per NEMA MG-1 Part 6 (figure 20). Non-ventilated versions (TENV), air over (TEAO) and with forced ventilation TEBC (IC416) are available on request. More information about IC416 option can be found in section 12 - Variable speed drive application.



Figure 20 – Cooling system

The cooling system (fan, non drive endshield and fan cover) is designed to minimize the noise level and improve thermal efficiency (figure 21).

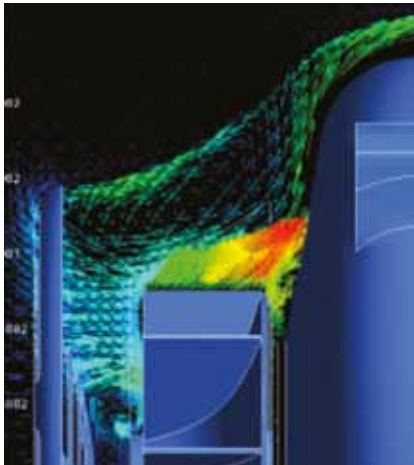

Figure 21 – Cooling system operation

W22 motors comply with NEMA MG-1 Part 9 Standard and the corresponding sound pressure levels. Table 3 show sound pressure levels in dB(A) which is obtained upon tests at 60 Hz.

Frame	Sound Pressure Level - dB(A)			
	2 Poles	4 Poles	6 Poles	8 Poles
143/5T	68	51	49	47
182/4T	69	58	52	50
213/5T	72	61	55	52
254/6T	72	64	59	54
284/6T	72	64	59	54
324/6T	76/ 74*	68/ 66*	62	56
364/5T	80/ 79*	70/ 67*	64	60
404/5T	80/ 79*	70/ 68*	64	60
444/5T 445/7T 447/9T	81	73	69	63
L447/9T	82	79	71	64
504/5T	81	75	70	64
586/7T	84	81/ 78*	77	75
588/9T	89	81	77	75

* Applicable to NEMA Premium Efficiency and Super Premium Efficiency motors
Table 3 – Sound pressure levels for 60 Hz motors

The noise level figures shown in table 4 are taken at no load. Under load the NEMA MG-1 Part 9 foresees an increase of the sound pressure levels as shown in table 4.

Rated Output, PN HP	2 poles	4 poles	6 poles	8 poles
1.0 < PN ≤ 15	2	5	7	8
15 ≤ PN ≤ 50	2	4	6	7
50 ≤ PN ≤ 150	2	3	5	6
150 ≤ PN ≤ 500	2	3	4	6

Table 4 – Maximum expected increase of sound pressure level for loaded motors.

The global noise level can be reduced up to 2 dB (A) with the installation of a drip cover.

4.2 Vibration level

Vibration of an electrical machine is closely related to its assembly on the application and, thus, it is generally desirable to perform vibration measurements under installation and operational conditions. Nevertheless, to allow evaluation of the vibration generated by the electrical machine itself in a way to allow reproducibility of the tests and the obtaining of comparative measurements, it is necessary to perform such measurements with the machine uncoupled, under controlled test conditions. The test conditions and vibration limits described here are those found in NEMA MG-1 Part 7. As an option, motors can be supplied with special vibration levels.

4.3 Impact resistance

The W22 motor complies with impact level IK08 – mechanical impact of 5J as per EN 62262 – Degrees of protection provided by enclosures for electrical equipment against external mechanical impacts (IK code) ensuring superior mechanical strength for the most demanding applications.

5. Shaft / Bearings

5.1 Shaft

The shaft of W22 standard motors is made of AISI 1040/45 steel, in frames 143T to 364/5T (all polarities), and 404/5T, 444/5T, 445/7T and 504/5T (2 pole) and in AISI 4140 steel for frames 404/5T and up (4 pole on) and 447/9T, L447/9T, 586/7T and 588/9T (2 pole). When supplied with roller bearings (optional for frames 254T and above), the shaft material must be AISI 4140.

When fitted with AISI 4140 steel shafts, W22 motors can employ roller bearings, making them suitable for heavy duty applications such as pulley and belt applications. The maximum allowable radial load on shaft ends is in accordance with NEMA MG-1 Part 14 Table 14-1A.

Important: Under such circumstances, the non drive end bearing cap needs to be replaced as the non drive end bearing must be locked.

For frames 364/5T and above, the shaft are supplied with a threaded centre hole and have dimensions shown in section 17 – Mechanical data.

W22 motors can be supplied with a second shaft end on request. As an option, W22 motors can be supplied with stainless steel shafts (AISI 316 and AISI 420) for highly corrosive environments.

Note: 2 pole motors will have as an option only the shaft end in stainless steel AISI 316.

5.2 Bearings

W22 motors are supplied with deep groove ball bearings as standard (figure 24). Optionally, frame size 254T and above can be supplied with NU series roller bearings, where high radial loads may occur.



Figure 22: Bearing view

The nominal bearing life L10h is 26,280 hours in conformance with maximum radial/axial loads as described in Tables 5 and 6. In standard configuration, with ball bearings, the drive end bearing is locked axially from frame 254T. To compensate for any axial movement the motors are fitted with pre-load washers for frames 143T to 326T and with pre-load springs for frames 364/5T to 588/9T.

When provided with roller bearings, the rear bearing is locked and the axial movement is compensated by the axial play of the front roller bearing.

Bearings lifetime depends on the type and size of the bearing, the radial and axial mechanical loads it is submitted to, operating conditions (environment, temperature), rotational

speed and grease life. Therefore, bearing lifetime is closely related to its correct use, maintenance and lubrication.

Respecting the quantity of grease and lubrication intervals allows bearings to reach the lifetime given. W22 motors in frames 254T and above are provided as standard with grease fittings in each endshield to permit the relubrication of the bearings. The lubrication interval is stamped on nameplate. The lubrication interval is shown in tables 7 and 8 - page 12.

It must be emphasized that excessive lubrication, i.e. a quantity of grease greater than that recommended on the motor nameplate, can result in the increase of bearing temperatures leading to reduced operating hours.

Note: L10 lifetime means that at least 90% of the bearings submitted to the maximum indicated loads will reach the number of hours indicated. For bearing lifetime in combined axial and radial loads condition contact WEG.

Important:

1 - Special applications

Motor operation under adverse operating conditions, such as higher ambient temperatures and altitudes or abnormal axial / radial loads, may require specific lubrication measures and alternative relubrication intervals to those indicated in the tables provided within this technical catalogue.

2 - Roller bearings

Roller bearings require a minimum radial load so as to ensure correct operation. They are not recommended for direct coupling arrangements, or for use on 2 pole motors (60 Hz).

3 - Frequency inverter driven motors

Bearing life may be reduced when a motor is driven by a frequency drive at speeds above nominal. Speed itself is one of the factors taken into consideration when determining motor bearing life.

4 - Motors with modified mounting configurations

For motors supplied with horizontal mounting but working vertically, lubrication intervals must be reduced by half.

5.2.1 Permissible loads

Permissible loads are in accordance with NEMA MG-1 (Table 14-1A), as shown in table 5.

Shaft loading for AC induction horizontal motors with ball bearings Maximum radial overhung load, in pounds, at center of N-W dimension				
Frame sizes	2 poles	4 poles	6 poles	8 poles
143T	106	154	179	192
145T	109	154	176	196
182T	180	227	260	287
184T	180	227	260	289
213T	230	300	350	380
215T	230	300	350	380
254T	470	593	703	774
256T	470	589	705	776
284T	570	735	838	929
286T	570	735	838	929
324T	660	860	990	1100
326T	660	850	980	1090
364T	820	1080	1240	1390
365T	820	1080	1240	1370
404T	-	1270	1450	1600
405T	-	1290	1480	1630
444T	-	1560	1760	1970
445T	-	1520	1760	1970
447T	-	1450	1660	1880
449T	-	1490	1660	1880

Table 5 - Permissible loads for NEMA motors

- 1 - All belt loads are considered to act in vertically downward direction.
- 2 - Overhung loads include belt tension and weight of sheave.
- 3 - For load at end of the shaft subtract 15%.
- 4 - Radial overhung load limitis based on bearing L-10 life of 26,280 hours.
- 5 - Overhung load limitis do not include any effect of unbalanced magnetic pull.

Axial loads

Maximum permissible axial thrust - 60 Hz - 26,280 hours - in pounds							
Frame	Poles	Horizontal		Vertical with shaft upwards		Vertical with shaft downwards	
		Pushing	Pulling	Pushing	Pulling	Pushing	Pulling
143/5T	2	60	70	60	80	60	70
	4	80	100	70	110	80	90
	6	110	130	100	140	110	120
	8	130	150	120	160	130	140
182/4T	2	90	130	70	150	90	120
	4	120	180	100	210	120	160
	6	160	230	140	270	170	210
213/5T	8	190	280	170	310	200	260
	2	120	230	90	270	130	210
	4	160	310	130	360	170	280
254/6T	6	200	380	170	430	210	360
	8	240	440	190	520	250	400
	2	460	300	420	360	530	260
284/6T	4	540	380	480	470	640	330
	6	650	490	600	600	750	430
	8	720	560	650	670	830	490
	2	610	400	540	510	710	340
324/6T	4	730	530	650	650	850	450
	6	850	650	760	810	1010	560
	8	990	790	910	920	1120	710
	2	650	420	540	600	820	310
364/5T	4	800	570	690	760	990	460
	6	960	730	830	940	1170	610
	8	1090	870	970	1070	1300	740
	2	790	610	620	870	1050	440
404/5T	4	1000	820	810	1110	1280	630
	6	1190	1010	980	1350	1530	800
	8	1370	1210	1170	1530	1690	1000
	2	750	570	550	900	1070	380
444/5T 445/7T	4	1070	890	810	1300	1480	640
	6	1280	1110	1000	1550	1730	830
	8	1440	1260	1150	1750	1930	970
	2	720	550	440	1000	1170	260
447/9T L447/9T	4	1210	1030	830	1660	1840	650
	6	1570	1390	1210	1960	2110	1030
	8	1710	1530	1280	2200	2380	1110
	2	710	540	Under request	1300	1480	Under request
504/5T	4	1550	1370	850	2430	2590	670
	6	1870	1690	1210	2740	2920	1030
	8	2160	2000	1480	3030	3210	1330
	2	640	470	Under request	1080	1260	Under request
586/7T 588/9T	4	1070	890	520	1730	1910	340
	6	1260	1090	660	2090	2270	490
	8	1480	1300	810	2340	2520	640
	2	570	390	Under request	1300	2430	Under request
586/7T 588/9T	4	1150	980	Under request	2430	2880	Under request
	6	1330	1170	Under request	2880	3350	Under request
	8	1480	1300	Under request	3350		Under request

Table 6 - Maximum permissible axial thrusts for ball bearings

Lubrication intervals

Frame	Lubrication intervals (hours)		
	RPM	Bearing	60 Hz
254/6T	3600	6309	20,000
	1800		25,000
	1200		
284/6T	900	6311	14,000
	3600		25,000
	1800		
	1200		
324/6T	900	6312	12,000
	3600		25,000
	1800		
	1200		
364/5T	900	6314	4000
	3600		12,000
	1800		
	1200		
404/5T	900	6316	17,000
	3600		20,000
	1800		
	1200		
444/5T 445/7T	900	6314	4000
	3600		8000
	1800		
	1200		
447/9T L447/9T	900	6319	13,000
	3600		17,000
	1800		
	1200		
504/5T	900	6314	4000
	3600		6000
	1800		
	1200		
586/7T 588/9T	900	6322	11,000
	3600		14,000
	1800		
	1200		

Table 7 - Lubrication intervals for ball bearings
Note: the amount of grease is indicated on the nameplate

Frame	Lubrication intervals (hours)		
	RPM	Bearing	60 Hz
254/6T	3600	NU309	12,000
	1800		25,000
	1200		
	900		
284/6T	3600	NU311	8000
	1800		25,000
	1200		
	900		
324/6T	3600	NU312	6000
	1800		21,000
	1200		
	900		
364/5T	900	NU314	25,000
	3600		9000
	1800		
	1200		
404/5T	900	NU316	13,000
	3600		7000
	1800		
	1200		
444/5T 445/7T	900	NU319	12,000
	3600		17,000
	1800		
	1200		
447/9T L447/9T	900	NU322	5000
	3600		9000
	1800		
	1200		
504/5T	900	NU322	15,000
	3600		4000
	1800		
	1200		
586/7T 588/9T	900	NU322	7000
	3600		13,000
	1800		
	1200		

Table 8 - Lubrication intervals for roller bearings
Note: the amount of grease is indicated on the nameplate

5.2.2 Bearing monitoring

On request, W22 motors can be equipped with bearing temperature detectors which monitor bearing operating conditions. The most commonly used accessory is the RTD temperature detector for continuous monitoring of bearing operating temperature.

This type of monitoring is extremely important considering that it directly affects the grease and bearing lives particularly on motors equipped with regreasing facilities.

6. Mounting forms

Motors are supplied, as standard, in the F-1 configuration, with the terminal box on top left hand side of the motor frame.



Figure 23 – F-1 mounting

The mounting configuration for the W22 motor lines comply with NEMA MG-1 Part 4. Standard mounting forms and their variations are shown in table 9.

Floor mountings			
Assembly F-1	Assembly F-2	Assembly F-3	
Wall mountings			
Assembly W-1	Assembly W-2	Assembly W-3	Assembly W-4
Assembly W-5	Assembly W-6	Assembly W-7	Assembly W-8
Assembly W-9	Assembly W-10	Assembly W-11	Assembly W-12
Ceiling mountings			
Assembly C-1	Assembly C-2	Assembly C-3	

Table 9 – Mountings configurations

7. Degree of protection / Sealing system / Painting

7.1 Degree of protection

As per NEMA MG-1 Part 5, the degree of protection of a rotating electrical machine consists of the letters IP (ingress protection), followed by two characteristic numerals, with the following meaning:

- First characteristic numeral: referred to protection of people against or approach to live parts and against contacts with moving parts (other than smooth rotating shafts and the like) inside the enclosure and protection of the machine against ingress of solid and foreign objects.
- Second characteristic numeral: protection of machines against harmful effects due to ingress of water.

W22 motors are supplied with degrees of protection in conformance with NEMA MG-1 Part 5. As standard, they are IP55, which means:

- First characteristic numeral 5: machine protected against dust. The enclosure is protected against contact with moving parts. Ingress of dust is not totally prevented, but dust does not enter in sufficient quantity to interfere with satisfactory operation of the machine.
- Second characteristic numeral 5: Machine protected against water jets. Water projected by a nozzle against the machine from any direction shall have no harmful effect.

7.2 Sealing system

The sealing system applied to the shaft of W22 motors in frame 143T to 326T is V-ring. For frames 364/5T to 504/5T the sealing system is the exclusive WSeal®, which consists of a double lipped V-ring with a metallic cap (see figure 24). This configuration operates like a labyrinth preventing ingress of water and dust into the motor.



Figure 24 – WSeal®

For frame sizes 586/7T and 588/9T the sealing system is the Taconite Labyrinth.

Alternatively, W22 motors can be supplied with other sealing systems, for example, Oilseal and the WEG exclusive W3 Seal®, among others (see Section 13 – Optional features). When fitted with flange, the recommended seal is Lip seal (no contact with liquid) and Oil seal (with contact with liquid).

7.3 Painting



Figure 25 – WEG painting plan

W22 motors of frame 143T to 215T are supplied as standard with WEG internal painting plan 207A. This plan consists of:

- Primer: one coat with 20 to 55 µm of alkyd primer;
- Finishing: one coat with 30 to 40 µm of styrenated alkyd synthetic enamel.

And, W22 motors of frame 254T up to 588/9T are supplied as standard with WEG internal painting plan 203A, consisting of:

- Primer: one coat with 20 to 55 µm of alkyd primer;
- Finishing: one coat with 50 to 75 µm of alkyd synthetic enamel.

These painting plans have a minimum resistance to the salt spray test of 120 hours (plan 207A) and 240 hours (plan 203A) in accordance with ASTM B117-03 and may be used in motors applied in normal environments, slightly severe, sheltered or non-sheltered, for industrial use, with low relative humidity, normal temperature variations and the presence of SO₂.

Note:

These painting plans are not recommended for direct exposure to acid steam, alkalis, solvents and salty environments.

Alternative painting plans are available on request, which are suitable to guarantee additional protection in aggressive environments, either protected or unprotected (see section 13 – Optional features).

7.3.1 Internal anti-corrosive painting

The integrity of the insulation system is the primary consideration when determining the lifetime of an electric motor. High humidity can result in premature deterioration of the insulation system, therefore for any ambient temperature with relative humidity above 95%, it is recommended to coat all internal components of the motor with an epoxy painting, also known as tropicalization.

8. Voltage / Frequency

NEMA MG-1 Part 12 states that the motor shall operate successfully under running conditions at rated load with a variation in the voltage or the frequency up to the following:

1. Plus or minus 10 percent of rated voltage, with rated frequency.
2. Plus or minus 5 percent of rated frequency, with rated voltage.

3. A combined variation in voltage and frequency of 10 percent (sum of absolute values) of the rated values, provided the frequency variation does not exceed plus or minus 5 percent of rated frequency.

Performance within these voltage and frequency variations will not necessarily be in accordance with the standards established for operation at rated voltage and frequency.

9. Ambient / Insulation

Unless otherwise specified, the rated power outputs shown in the electrical data tables within this catalogue refer to continuous duty operation S1, as per NEMA MG-1 Part 14 and under the following conditions:

- With ambient temperature range -30°C to +40°C;
- With altitudes up to 3300 feet (1000 meters) above sea level.

For operating temperatures and altitudes differing from those above, the factors indicated in table 10 must be applied to the nominal motor power rating in order to determine the derated available output (Pmax).

$P_{max} = P_{nom} \times \text{correction factor}$

T (°C)	Altitude (m)								
	1000	1500	2000	2500	3000	3500	4000	4500	5000
10							0.97	0.92	0.88
15						0.98	0.94	0.90	0.86
20					1.00	0.95	0.91	0.87	0.83
25				1.00	0.95	0.93	0.89	0.85	0.81
30			1.00	0.96	0.92	0.90	0.86	0.82	0.78
35		1.00	0.95	0.93	0.90	0.88	0.84	0.80	0.75
40	1.00	0.97	0.94	0.90	0.86	0.82	0.80	0.76	0.71
45	0.95	0.92	0.90	0.88	0.85	0.81	0.78	0.74	0.69
50	0.92	0.90	0.87	0.85	0.82	0.80	0.77	0.72	0.67
55	0.88	0.85	0.83	0.81	0.78	0.76	0.73	0.70	0.65
60	0.83	0.82	0.80	0.77	0.75	0.73	0.70	0.67	0.62
65	0.79	0.76	0.74	0.72	0.70	0.68	0.66	0.62	0.58
70	0.74	0.71	0.69	0.67	0.66	0.64	0.62	0.58	0.53
75	0.70	0.68	0.66	0.64	0.62	0.60	0.58	0.53	0.49
80	0.65	0.64	0.62	0.60	0.58	0.56	0.55	0.48	0.44

Table 10 – Correction factors for altitude and ambient temperature

Bearing lubrication intervals will change under operating conditions other than 40°C maximum ambient temperature and 1000 meters above sea level. Contact WEG for more information.

All W22 motors are wound with the WISE® insulation system which consists of enamelled copper wire meeting temperatures up to 200°C and impregnated with solvent free resin. The WISE® system also permits motor operation with variable speed drives (see section 11).

9.1 Space heaters

The use of space heaters are recommended in two situations:

- Motors installed in environments with relative air humidity up to 95%, in which the motor may remain idle for periods greater than 24 hours;
- Motors installed in environments with relative air humidity

greater than 95%, regardless of the operating schedule. It should be highlighted that in this situation it is strongly recommended that an epoxy paint known as internal anti-corrosive painting is applied in the internal components of the motor.

More information can be obtained in section 7.3.

For all frame sizes, W22 motors can be provided with space heaters suitable for 110-127 V, 220-240 V and 380-480 V. Motors in frame sizes 586/7T and 588/9T are supplied with space heaters for 220-240 V as standard. As an option, dual voltage heaters of 110-127 / 220-240 V can be supplied for frame sizes 182T to 588/9T.

The power rating and number of space heaters fitted depends on the size of the motor as indicated in table 11 below:

Frame	Quantities	Total power rated (W)
143 to 145	1	11
182 to 184	2	22
213 to 256	2	30
284 to 326	2	38
364/5 to 404/5	2	56
444/5 to 504/5	2	140
586/7 to 588/9	2	174

Table 11 – Power and quantity of space heaters

10. Motor protections

Protections available for W22 can be classified as follows:

- Based on operating temperature
- Based on operating current.

In section 12 - Construction features it is possible to identify the type of protection for each W22 line.

10.1 Protection based on operating temperature

Continuous duty motors must be protected from overload either by a device integrated into the motor winding or via an independent protection system, usually a thermal relay with rated or setting current, equal to or below the value obtained when multiplying the power supply rated current (I_n), as per table 12.

Service Factor	Relay setting current
1.0 up to 1.15	$I_n \times S.F.$
≥ 1.15	$(I_n \times S.F.) - 5\%$

Table 12 – Relay setting current referred to service factor

RTD

These are temperature detectors (figure 26) with operating principle based on the properties that some materials vary the electric resistance with the variation in temperature (usually platinum, nickel or copper).



Figure 26 - RTD

They are also fitted with calibrated resistances that vary linearly with temperature, allowing continuous reading of motor operating temperature through a monitoring display, with high precision rate and response sensitivity. The same detector can serve as alarm (with operation above the regular operating temperature) and trip (usually set up for the maximum temperature of the insulation class).

Thermistor (PTC)

These are thermal protectors consisting of semiconductor detectors with sudden variation of the resistance when reaching a certain temperature (figure 27).



Figure 27 – Thermistor (PTC)

PTC is considered a thermistor with the resistance increasing drastically to a well defined temperature figure. This sudden resistance variation blocks the PTC current, causing the output relay to operate, and the main circuit to switch-off. The thermistors are of small dimensions, do not wear and have quicker response if compared to other protectors, although they do not allow continuous monitoring of motor operating temperature.

Together with their electronic circuits, these thermistors provide full protection against overheating caused by overload, under or overvoltage or frequent reversing operations.

Where thermistor protection is required to provide both alarm and trip operation, it is necessary for each phase of the motor winding to be equipped with two sets of appropriately rated thermistors.

WEG Automation has a product called RPW which is an electronic relay intended specifically to read the PTC signal and operate its output relay. For more information go to the website www.weg.net.

Thermostats

These are silver-contact thermal sensors, normally closed, that operate at certain temperature rise. When their operating temperature decreases, they go back to the original position instantaneously, allowing the silver contact to close again. The thermostats are series-connected with the contactor coil, and can be used either as alarm or trip.

There are also other types of thermal protectors such as PT-1000, KTY and thermocouples. Contact your local WEG office closest to you for more information.

10.2 Protection based on operating current

Overloads are processes that usually make the temperature increase gradually. To solve this problem, the thermal protectors described in item 10.1 are quite suitable. However, the only way to protect motors against short-circuit currents is the application of fuses. This type of protection depends directly on the current and it is highly effective in cases of locked rotor.

WEG Automation supplies fuses in versions D and NH. Go to the site www.weg.net for more information.

11. Variable speed drive application

11.1 Considerations regarding voltage spikes and the insulation system

The stator windings of W22 motors are wound with class F insulation (class H optional) and are suitable for either DOL starting or via a variable speed drive. They incorporate the WEG exclusive insulation system – WISE® (WEG Insulation System Evolution) – which ensures superior electrical insulation characteristics. The stator winding is suitable for variable speed drive application, taking into account the limits shown in Table 13.

Motor rated voltage	Voltage Spikes at motor terminals (phase-phase)	dV/dt * at motor terminals (phase-phase)	Rise time*	Minimum Time Between Successive Pulses
$V_{rated} \leq 460\text{ V}$	$\leq 1600\text{ V}$	$\leq 5200\text{ V}/\mu\text{s}$	$\geq 0.1\ \mu\text{s}$	$\geq 6\ \mu\text{s}$
$460\text{ V} < V_{rated} \leq 575\text{ V}$	$\leq 1800\text{ V}$	$\leq 6500\text{ V}/\mu\text{s}$		
$575\text{ V} < V_{rated} \leq 690\text{ V}$	$\leq 2200\text{ V}$	$\leq 7800\text{ V}/\mu\text{s}$		

Table 13 – Supportability of random wound motors' insulation system * dV/dt and Rise time definition according to Nema Std. MG1 – Part 30.

Notes:

- In order to protect the motor insulation system, the maximum recommended switching frequency is 5 kHz.
- If one or more of the above conditions is not attended, a filter (load reactor or dV/dt filter) must be installed in the output of the VSD.
- General purpose motors with rated voltage greater than 575 V, which at the time of purchase did not have any indication of operation with VSD, are able to withstand the electrical limits set in the table above for rated voltage up to 575 V. If such conditions are not fully satisfied, output filters must be used.
- General purpose motors of the dual voltage type, for example 380/660 V, which at the time of purchase did not have any indication of operation with VSD, are able to be driven by a VSD in the higher voltage only if the limits set in the table above for rated voltage up to 460 V are fully attended in the application. Otherwise, a load reactor or a dV/dt filter must be installed in the VSD output.

11.2 Torque restrictions on variable speed drive applications

In order to keep the temperature rise of WEG motors within acceptable levels, when under VSD supply, the speed range-related loadability limits established in Table 14 must be respected.

Note:

Applications with motors rated for use in hazardous areas must be particularly evaluated - in such case please contact WEG.

TEFC NEMA High Efficiency Motors					
Frame size	Constant torque	Variable torque	Constant power ^(v)	Drive	Comments
143 - 589 ⁽ⁱⁱⁱ⁾	12:1	1000:1	60 - 120 Hz	Any	Constant flux
	100:1 ⁽ⁱⁱ⁾	-	60 - 120 Hz	WEG ⁽ⁱⁱ⁾	Optional flux
589 ^(iv)	4:1	1000:1	60 - 120 Hz	Any	Constant flux
	10:1	-	60 - 120 Hz	WEG ⁽ⁱⁱ⁾	Optional flux
TEFC NEMA Premium Efficiency Motors					
Frame size	Constant torque	Variable torque	Constant power ^(v)	Drive	Comments
143 - 589 ⁽ⁱⁱⁱ⁾	20:1	1000:1	60 - 120 Hz	Any	Constant flux
	1000:1 ⁽ⁱⁱ⁾	-	60 - 120 Hz	WEG ⁽ⁱⁱ⁾	Optional flux
589 ^(iv)	6:1	1000:1	60 - 120 Hz	Any	Constant flux
	12:1	-	60 - 120 Hz	WEG ⁽ⁱⁱ⁾	Optional flux

Table 14 – Loadability limits for W22 motors operating with VSD

(i) Satisfactory motor performance depends on proper drive setup – please contact WEG

(ii) WEG drive CFW-09 version 2.40 or higher, operating in sensorless (open loop) vector mode

(iii) Motors with rated power $\leq 250\text{ hp}$. Criteria also valid for motors of the frame sizes 447 and 449

(iv) Motors with rated power $> 250\text{ hp}$. Criteria also valid for motors of the frame sizes 447 and 449

(v) Maximum speeds for safe operation (mechanical issues) must be also observed – refer to Table 16. For CSA-certified 2-pole motors, constant horsepower is limited to the range of 60 - 90 Hz.

Notes:

- The speed ranges stated above are related to the motor thermal capability only. Speed regulation will depend on VSD mode of operation and proper adjustment.
- W22 motors of all frame sizes can be blower cooled (independently ventilated) under request. In such case, the motor will be suitable for variable and constant torque applications up to 1000:1 with any drive.

The relations in Table 14 correspond to speed ranges of operation. Considering 60 Hz as the base operating frequency, the following equivalence is valid:

Relation	Frequency range
4:1	15 - 60 Hz
10:1	6 - 60 Hz
12:1	5 - 60 Hz
20:1	3 - 60 Hz
100:1	0.6 - 60 Hz
1000:1	0.06 - 60 Hz

Table 15 – Operation range description

HP	TEFC Motors			ODP Motors		
	2 poles	4 poles	6 poles	2 poles	4 poles	6 poles
0.25	7200	3600	2400	7200	3600	2400
0.33	7200	3600	2400	7200	3600	2400
0.50	7200	3600	2400	7200	3600	2400
0.75	7200	3600	2400	7200	3600	2400
1	7200	3600	2400	7200	3600	2400
1.5	7200	3600	2400	7200	3600	2400
2	7200	3600	2400	7200	3600	2400
3	7200	3600	2400	7200	3600	2400
5	7200	3600	2400	7200	3600	2400
7.5	5400	3600	2400	7200	3600	2400
10	5400	3600	2400	5400	3600	2400
15	5400	3600	2400	5400	3600	2400
20	5400	3600	2400	5400	3600	2400
25	5400	2700	2400	5400	2700	2400
30	5400	2700	2400	5400	2700	2400
40	4500	2700	2400	5400	2700	2400
50	4500	2700	2400	4500	2700	2400
60	3600	2700	2400	4500	2700	2400
75	3600	2700	2400	3600	2700	2400
100	3600	2700	1800	3600	2700	1800
125	3600	2700	1800	3600	2700	1800
150	3600	2700	1800	3600	2700	1800
200	3600	2250	1800	3600	2700	1800
250	3600	2250	1800	3600	2250	1800

HP	TEFC Motors			ODP Motors		
	2 poles	4 poles	6 poles	2 poles	4 poles	6 poles
300	3600	2250	1800	3600	2250	1800
350	3600	1800	1800	3600	2250	1800
400	3600	1800	-	3600	2250	-
450	3600	1800	-	3600	2250	-
500	3600	1800	-	3600	2250	-

Table 16 – Maximum safe operating speeds (rpm) for W22 motors driven by VSD

Notes:

1. The values in the table are based on mechanical limitations. For operation above nameplate speed, the electrical limitations (motor torque capability) must be also observed.
2. The limits established in Table 15 are in accordance with the Nema Std. MG 1 - Part 30.
3. The permissible overspeed value is 10% above the limits given in Table 15 (not to exceed 2 minutes in duration) except where the maximum safe operating speed is the same as the synchronous speed at 60 Hz - in such case, please contact WEG.
4. Operation above nameplate speed may require specially refined motor balancing. In such case, vibration and noise limits per Nema MG1 Parts 7 and 9, respectively, are not applicable.
5. Bearing life will be affected by the length of time the motor is operated at various speeds.
6. For speeds and ratings not covered by the table above, please contact WEG.

11.3 Considerations regarding bearing currents

Motors up to frame size 445T generally do not require special features with respect to the bearings for variable speed drive application. From frame size 447T upwards additional measures should be taken in order to avoid detrimental bearing currents. This can be accomplished by means of the use of an insulated bearing or an insulated hub endshield in the non drive end side and a shaft grounding brush mounted on the drive endshield. W22 motors are normally supplied duly protected per such recommendations when operation with VSD is mentioned at the time of purchase. Otherwise, WEG can modify older motors that were not originally supplied with such protection under request.

11.4 Forced ventilation kit

For those cases where an independent cooling system is required, the W22 motors can be supplied with a forced ventilation kit, as shown in figure 28.

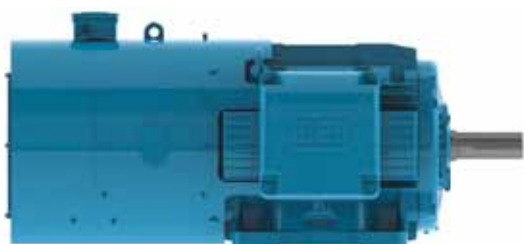

Figure 28 – Forced ventilation kit for W22 motors

When the forced ventilation kit is assembled on the motor in the factory, the overall motor length will be as shown in table 15. As a local stock modification option, an alternative forced ventilation kit can be fitted. Please contact your local WEG office for details of these dimensions.

Frame	Total motor length (inches)	
	Without forced ventilation	With forced ventilation
143T	12.346	21.952
L143T	13.566	23.172
145T	13.346	22.952
L145T	14.566	24.172
182T	14.860	25.372
L182T	16.041	26.553
184T	15.860	26.372
L184T	17.041	27.553
213T	18.021	28.375
L213T	19.527	29.881
215T	19.517	29.871
L215T	20.905	31.259
254T	23.213	33.331
256T	24.945	35.063
284TS	25.061	34.667
284T	26.433	36.039
286TS	26.557	36.163
286T	27.929	37.535
324TS	28.120	37.844
324T	29.620	39.344
326TS	29.616	39.340
326T	31.116	40.840
364/5TS	32.276	43.457
364/5T	34.251	45.432
404/5TS	36.732	46.653
404/5T	39.730	49.651
444/5TS	41.200	52.106
444/5T	44.950	55.856
445/7TS	44.951	55.857
445/7T	48.701	59.607
447/9TS	52.588	63.494
447/9T	56.338	67.244
L447/9TS	53.431	61.896
L447/9T	57.181	65.646
504/5TS	48.215	56.680
504/5T	54.095	62.560
586/7TS	55.027	69.751
586/7T	61.902	76.626
588/9TS	62.506	77.230
588/9T	69.381	84.105

Table 17 – Forced ventilation dimensions

11.5 Encoders

W22 motors may be supplied with encoders for speed control in closed loop. Encoders can be fitted to motors with either forced ventilation or with shaft mounted cooling fan (TEFC). When encoders are fitted to TEFC machines, motors may not have a second shaft end or be fitted with drip cover. The following models of encoder are available for supply:

- Dynapar - HS35 - 1024ppr (hollow shaft)
- Kübler - Model 5020 - 1024ppr (hollow shaft)
- Hengstler - RI58 - 1024ppr (hollow shaft)
- Line & Linde - XH861 - 1024ppr (hollow shaft)
- Hubner Berlin - HOG 10 - 1024ppr (hollow shaft)
- Hubner Guinsen - FGH4 - 1024ppr (shaft)
- Dynapar - HSD38 - 1024ppr (hollow shaft)
- Avtron - HS25A - 1024ppr (hollow shaft)
- Avtron - HS35A - 1024ppr (hollow shaft)
- Avtron - HS35M - 1024ppr (hollow shaft)

Other models can be supplied on request.

Note: The encoders described above are of the 1024 pulses per revolution type. As an option, models of 2048 pulses per revolution are available.

For more information on VSD motor applications, visit our website (www.weg.net) and download the Technical Guide - Induction motors fed by PWM frequency converters (code 028).

12. Construction features

Frame		143T	145T	182T	184T	213T	215T	254T	256T	284T	286T	
Mechanical features												
Nameplate markings		UR, CSA										
Mounting		F-1										
Frame	Material	Cast Iron FC-200										
Degree of protection (IP rating)		IP55										
Grounding		Simple grounding (one inside the terminal box and one on the frame)										
Cooling method (IC)		Totally enclosed fan-cooled (IC411)										
Fan	Material	2-4P		Polypropylene								
		6-12P		Polypropylene								
Fan cover	Material	Steel						Cast Iron FC-200				
Endshields	Material	Cast Iron FC-200										
Drain Plug		Automatic Plastic						Fitted with rubber drain plug				
Bearings	Shielded/clearance (DE)		ZZ / Normal						Open / C3			
	Shielded/clearance (NDE)		ZZ / Normal						Open / C3			
	Locating bearing configuration		Without bearing cap and with preload washer at NDE						Locked DE bearing and preload washer at NDE			
	Drive end	2P	6205	6205	6207	6207	6308	6308	6309	6309	6311	6311
		4 - 12P										
Non-drive end	2P	6204	6204	6206	6206	6207	6207	6209	6209	6211	6211	
	4 - 12P											
Bearing seal		V-ring										
Lubrication	Type of grease		Mobil Polyrex EM									
	Grease fitting		None						With grease relief fitting			
Terminal block		None										
Terminal box	Material	Cast Iron FC-200										
Leads inlet	Main T-box	Size	NPT 3/4"	NPT 3/4"	NPT 1"	NPT 1"	NPT 1"	NPT 1"	NPT 1 1/2"	NPT 1 1/2"	NPT 1 1/2"	NPT 1 1/2"
	Plug		Flat plastic plug for transportation and storage									
Shaft	Material	2P	SAE 1040/45									
		4 - 12P										
	DE threaded hole	2P	-	-	-	-	-	-	-	-	-	-
		4 - 12P										
	NDE(*) threaded hole	2P	-	-	-	-	-	-	-	-	M12 x 1.25	
4 - 12P												
Vibration velocity limit		0.15 in./sec peak										
Nameplate	Material	Stainless Steel AISI 304										
Painting	Type	207A						203A				
	Color	Blue RAL 5009 – High Efficiency and NEMA Premium Efficiency										
		Green RAL 6002 - Super Premium Efficiency										
Electrical features												
Design		B										
Voltage		208-230/460 V with 9 leads						208-230/460 V with 12 leads				
Winding	Material	Copper										
	Impregnation	Dip and Bake - Polyester										
	Insulation class	F (DT=80K)										
Service factor		1.25 for High Efficiency and NEMA Premium Efficiency up to 100 HP and for all Super Premium Efficiency motors 1.15 for High Efficiency and NEMA Premium Efficiency of 125 HP and above										
Rotor		Aluminum die cast										
Space heater		None										

(*) NDE Threaded hole is an exclusive feature of NEMA Premium Efficiency and Super Premium Efficiency versions

Frame		324T	326T	364/5T	404/5T	444/5T	445/7T	447/9T	L447/9T	504/5T	586/7T	588/9T	
Mechanical features													
Nameplate markings		UR, CSA											
Mounting		F-1											
Frame	Material	Cast Iron FC-200											
Degree of protection (IP rating)		IP55											
Grounding		Simple grounding (one inside the terminal box and one on the frame)	Double grounding (inside the terminal box + 2 on the frame)				Double grounding + additional (one inside the terminal box and three on the frame)						
Cooling method (IC)		Totally enclosed fan-cooled (IC411)											
Fan	Material	2-4P	Polypropylene						2P: Polypropylene 4P: Aluminum	Polypropylene	2P: Polypropylene 4P: Aluminum	Aluminum	
		6-12P	Polypropylene						Aluminium				
Fan cover	Material	Cast Iron FC-200											
Endshields	Material	Cast Iron FC-200											
Drain plug		Fitted with rubber drain plug											
Bearings	Shielded/clearance (DE)		Open / C3										
	Shielded/clearance (NDE)		Open / C3										
	Locating bearing configuration		Locked DE bearing and preload washer at NDE		Locked on DE with internal and external bearing caps and with preload springs at NDE								
	Drive end	2P	6312	6312	6314	6314	6314	6314	6314	6314	6316	6314	6314
		4 - 12P				6316	6319	6319	6322	6322	6319	6322	6319
Non-drive end	2P	6212	6212	6314		6314	6314	6314	6314	6314	6314	6314	6314
	4 - 12P					6316	6316	6319	6319	6319	6316	6319	6319
Bearing seal		V-ring		WSeal®						Taconite Labyrinth			
Lubrication	Type of Grease		Mobil Polyrex EM										
	Grease fitting		With grease relief fitting										
Terminal block		None											
Terminal box	Material	Cast Iron FC-200											
Leads inlet	Main T-box	Size	NPT 2"	NPT 2"	NPT 3"	NPT 3"	2 x NPT 3"	2 x NPT 3"	2 x NPT 3"	2 x NPT 3" (removable gland plate)	2 x NPT 3" (removable gland plate)	2 x NPT 3" (removable gland plate)	
	Plug		Flat plastic plug for transportation and storage										
Shaft	Material	2P	SAE 1040/45				SAE 1040/45			SAE 4140	SAE 1040/45	SAE 4140	
		4 - 12P	SAE 4140										
	DE threaded hole	2P	-	-	UNC 3/4"	UNC 3/4"	UNC 3/4"	UNC 3/4"	UNC 3/4"	UNC 3/4"	UNC 3/4"	UNC 3/4"	UNC 3/4"
		4 - 12P	-	-	UNC 3/4"	UNC 3/4"	UNC 3/4"	UNC 3/4"	UNC 3/4"	UNC 3/4"	UNC 3/4"	UNC 3/4"	UNC 3/4"
NDE(*) threaded hole	2P	M12 x 1.25		M20 x 2.5		M20 x 2.5	M20 x 2.5	M20 x 2.5	M20 x 2.5	M20 x 2.5	M20 x 2.5	M20 x 2.5	
	4 - 12P	M12 x 1.25		M20 x 2.5		M20 x 2.5	M20 x 2.5	M20 x 2.5	M20 x 2.5	M20 x 2.5	M20 x 2.5	M20 x 2.5	
Vibration velocity limit		0.15 in./sec peak											
Nameplate	Material	Stainless Steel AISI 304											
Painting	Type	203A											
	Color	Blue RAL 5009 – High Efficiency and NEMA Premium Efficiency Green RAL 6002 - Super Premium Efficiency											
Electrical features													
Design		B											
Voltage		208-230/460 V with 12 leads										460 V with 6 leads	
Winding	Material	Copper											
	Impregnation	Dip and bake - Polyester	Continuous resin flow - Polyester										
	Insulation class	F (DT=80K)											
Service factor		1.25 for High Efficiency and NEMA Premium Efficiency up to 100 HP and for all Super Premium Efficiency motors 1.15 for High Efficiency and NEMA Premium Efficiency of 125 HP and above										1.00	
Rotor		Aluminum die cast											
Space heater		None										200-240 Vac	

13. Optional features

Frame	143T	145T	182T	184T	213T	215T	254T
Terminal box							
Accessory terminal box	0	0	0	0	0	0	0
Terminal box with removable base	NA	NA	NA	NA	NA	NA	NA
Gland plate	0	0	0	0	0	0	0
Epoxy compound on leads entry	0	0	0	0	0	0	0
Self-extinguishing foam at leads entry	S	S	S	S	S	S	S
Terminal block							
BMC terminal block - six pin	0	0	0	0	0	0	0
BMC terminal block - twelve pin	0	0	0	0	0	0	0
HGF connection terminal	NA	NA	NA	NA	NA	NA	NA
Cable glands							
Plastic cable gland	0	0	0	0	0	0	0
Brass cable gland	0	0	0	0	0	0	0
Flange							
Flange D	0	0	0	0	0	0	0
Flange C	0	0	0	0	0	0	0
Fan							
Polypropylene (2 poles)	S	S	S	S	S	S	S
Polypropylene (from 4 poles on)	S	S	S	S	S	S	S
Conductive Plastic (2 poles)	0	0	0	0	0	0	0
Conductive Plastic (from 4 poles on)	0	0	0	0	0	0	0
Aluminum (2 poles)	0	0	0	0	0	0	0
Aluminum (from 4 poles on)	0	0	0	0	0	0	0
Cast iron	0	0	0	0	0	0	0
Bronze	0	0	0	0	0	0	0
Fan cover							
Steel plate	S	S	S	S	S	S	0
Cast iron	0	0	0	0	0	0	S
Bearing							
Roller bearing (DE)	NA	NA	NA	NA	NA	NA	0
Insulated drive end bearing	NA	NA	NA	NA	NA	NA	NA
Insulated non drive end bearing	NA	NA	NA	NA	NA	NA	NA
Bearing cap							
Without bearing cap	S	S	S	S	S	S	NA
With bearing cap	0	0	0	0	0	0	S
Bearing sealing							
Nitrilic rubber lip seal	0	0	0	0	0	0	0
Nitrilic rubber oil seal	0	0	0	0	0	0	0
Nitrilic rubber oil seal double lip	0	0	0	0	0	0	0
Viton lip seal	0	0	0	0	0	0	0
Viton oil seal	0	0	0	0	0	0	0
Viton oil seal with stainless steel spring	0	0	0	0	0	0	0
Taconite labyrinth	0	0	0	0	0	0	0
W3 Seal®	0	0	0	0	0	0	0
Shaft							
Second shaft end	0	0	0	0	0	0	0
TS shaft end (from 4 poles on)	NA	NA	NA	NA	NA	NA	NA
Tapped center hole	0	0	0	0	0	0	0
Locking shaft device (standard for roller bearing motors)	NA	NA	NA	NA	0	0	0
Lubrication							
Mobil Polyrex EM	S	S	S	S	S	S	S
Aeroshell 7	0	0	0	0	0	0	0
Isoflex NBU 15	0	0	0	0	0	0	0
Grease nipple							
Carbon steel grease nipple	0	0	0	0	0	0	S
Stainless steel grease nipple	0	0	0	0	0	0	0
Drain							
Rubber drain plug	NA	NA	NA	NA	NA	NA	S
Plastic drain plug (opened)	S	S	S	S	S	S	NA
Plastic drain plug (closed)	0	0	0	0	0	0	NA
Threaded drain plug	0	0	0	0	0	0	0
Stainless steel drain plug (closed)	0	0	0	0	0	0	0
T-type drain plug (opened)	0	0	0	0	0	0	0
Degree of protection							
IP56	0	0	0	0	0	0	0
IP65	0	0	0	0	0	0	0
IP66	0	0	0	0	0	0	0

Notes: 1) Other optional features, on request.

2) Some combinations of optional features are not allowed – then contact WEG.

S (Standard)

NA (Not available)

0 (Optional)

256T	284T	286T	324T	326T	364/5T	404/5T	444/5T	445/7T	447/9T	L447/9T	504/5T	586/7T	588/9T
Terminal box													
0	0	0	0	0	0	0	0	0	0	0	0	0	0
NA	NA	NA	NA	NA	0	0	0	0	0	S	0	S	S
0	0	0	0	0	0	0	0	0	0	0	0	0	0
0	0	0	0	0	0	0	0	0	0	0	0	0	0
S	S	S	S	S	S	S	S	S	S	S	S	S	S
Terminal block													
0	0	0	0	0	0	0	0	0	0	0	0	0	NA
0	0	0	0	0	0	0	0	0	0	0	0	0	NA
NA	NA	NA	NA	NA	NA	NA	NA	NA	NA	NA	NA	NA	0
Cable glands													
0	0	0	0	0	0	0	0	0	0	0	0	0	0
0	0	0	0	0	0	0	0	0	0	0	0	0	0
Flange													
0	0	0	0	0	0	0	0	0	0	0	0	0	0
0	0	0	0	0	0	0	0	0	0	0	0	0	0
Fan													
S	S	S	S	S	S	S	S	S	S	S	S	S	NA
S	S	S	S	S	S	S	S	S	NA	NA	S	NA	NA
0	0	0	0	0	0	0	0	0	0	0	0	NA	NA
0	0	0	0	0	0	0	0	0	NA	NA	0	NA	NA
0	0	0	0	0	0	0	0	0	0	0	0	0	S
0	0	0	0	0	0	0	0	0	S	S	0	S	S
0	0	0	0	0	0	0	0	0	0	0	0	0	0
0	0	0	0	0	0	0	0	0	0	0	0	0	0
Fan cover													
0	0	0	0	0	0	0	0	0	0	0	0	0	0
S	S	S	S	S	S	S	S	S	S	S	S	S	S
Bearing													
0	0	0	0	0	0	0	0	0	0	0	0	0	0
NA	NA	NA	NA	NA	0	0	0	0	0	0	0	0	0
NA	NA	NA	NA	NA	0	0	0	0	0	0	0	0	0
Bearing cap													
NA	NA	NA	NA	NA	NA	NA	NA	NA	NA	NA	NA	NA	NA
S	S	S	S	S	S	S	S	S	S	S	S	S	S
Bearing sealing													
0	0	0	0	0	0	NA	NA	NA	NA	NA	NA	NA	NA
0	0	0	0	0	0	NA	NA	NA	NA	NA	NA	NA	NA
0	0	0	0	0	0	NA	NA	NA	NA	NA	NA	NA	NA
0	0	0	0	0	0	0	0	0	0	0	0	0	0
0	0	0	0	0	0	0	0	0	0	0	0	0	0
0	0	0	0	0	0	0	0	0	0	0	0	0	0
0	0	0	0	0	0	0	0	0	0	0	0	S	S
0	0	0	0	0	0	0	0	0	0	0	0	0	0
Shaft													
0	0	0	0	0	0	0	0	0	0	0	0	0	0
NA	0	0	0	0	0	0	0	0	0	0	0	0	0
0	0	0	0	0	S	S	S	S	S	S	S	S	S
0	0	0	0	0	0	0	0	0	0	0	0	0	0
Lubrication													
S	S	S	S	S	S	S	S	S	S	S	S	S	S
0	0	0	0	0	0	0	0	0	0	0	0	0	0
0	0	0	0	0	0	0	0	0	0	0	0	0	0
Grease nipple													
S	S	S	S	S	S	S	S	S	S	S	S	S	S
0	0	0	0	0	0	0	0	0	0	0	0	0	0
Drain													
S	S	S	S	S	S	S	S	S	S	S	S	S	S
NA	NA	NA	NA	NA	NA	NA	NA	NA	NA	NA	NA	NA	NA
NA	NA	NA	NA	NA	NA	NA	NA	NA	NA	NA	NA	NA	NA
0	0	0	0	0	0	0	0	0	0	0	0	0	0
0	0	0	0	0	0	0	0	0	0	0	0	0	0
0	0	0	0	0	0	0	0	0	0	0	0	0	0
Degree of protection													
0	0	0	0	0	0	0	0	0	0	0	0	0	0
0	0	0	0	0	0	0	0	0	0	0	0	0	0
0	0	0	0	0	0	0	0	0	0	0	0	0	0

Frame	143T	145T	182T	184T	213T	215T	254T
Painting plan							
202E Primer: One coat with 20 to 55 µm of alkyd oxide red Intermediate: One coat with 20 to 30 µm of isocyanate epoxy paint Finishing: One coat with 100 to 140 µm of epoxy paint N2628 Recommended for pulp and paper, mining and chemical industries Note: Salt-spray resistance: 300h	0	0	0	0	0	0	0
202P Primer: One coat with 20 to 55 µm of alkyd oxide red Intermediate: One coat with 20 to 30 µm of isocyanate epoxy paint Finishing: One coat with 70 to 100 µm of polyurethane paint N2677 Recommended for food processing industries. Note: Salt-spray resistance: 300h	0	0	0	0	0	0	0
211E Primer: One coat with 20 to 55 µm of alkyd oxide red Intermediate: One coat with 20 to 30 µm of isocyanate epoxy paint Finishing: One coat with 70 to 100 µm of polyurethane paint N2677 Recommended for food processing industries. Note: Salt-spray resistance: 10,000h	0	0	0	0	0	0	0
211P Primer: One coat with 20 to 55 µm of alkyd oxide red Intermediate: One coat with 20 to 30 µm of isocyanate epoxy paint Finishing: One coat with 70 to 100 µm of polyurethane paint N2677 Recommended for food processing industries. Note: Salt-spray resistance: 10,000h	0	0	0	0	0	0	0
212E Primer: One coat with 75 to 105 µm of epoxy paint N1277 Intermediate: One coat with 100 to 140 µm of epoxy paint N2630 Finishing: One coat with 100 to 140 µm of epoxy paint N2628 Recommended for applications in pulp and paper, mining, chemical and petrochemical industries Note: Salt-spray resistance: 15,000h	0	0	0	0	0	0	0
212P Primer: One coat with 75 to 105 µm of epoxy paint N1277 Intermediate: One coat with 100 to 140 µm of epoxy paint N2630 Finishing: One coat with 70 to 100 µm of PU paint N2677 Recommended for applications in pulp and paper, mining, chemical and petrochemical industries Note: Salt-spray resistance: 12,000h	0	0	0	0	0	0	0
213E Primer: One coat with 75 to 90 µm of Silicate Ethyl paint N1661 Intermediate: One coat with 35 to 50 µm of epoxy paint N1202 Finishing: One coat with 240 to 340 µm of epoxy paint N2628 Recommended for off-shore oil platform Note: Salt-spray resistance: 10,000h	0	0	0	0	0	0	0
Inside of terminal box painting (Munsell 2.5 YR 6/14)	0	0	0	0	0	0	0
Internal epoxy painting	0	0	0	0	0	0	0
Other mechanical optionals							
Drip cover	0	0	0	0	0	0	0
Rubber Slinger	0	0	0	0	0	0	0
Stainless steel hardware	NA	NA	NA	NA	0	0	0
Grease outlet through endshield	0	0	0	0	0	0	0
Electrical optionals							
Winding thermal protection							
Alarm thermostat	0	0	0	0	0	0	0
Tripping thermostat	0	0	0	0	0	0	0
RTD two wires, one per phase	0	0	0	0	0	0	0
RTD two wires, two per phase	NA	NA	NA	NA	NA	NA	NA
RTD three wires, one per phase	0	0	0	0	0	0	0
RTD three wires, two per phase	NA	NA	NA	NA	NA	NA	NA
Alarm thermistor	0	0	0	0	0	0	0
Tripping thermistor	0	0	0	0	0	0	0
Bearing thermal protection							
Thermostat	NA	NA	NA	NA	NA	NA	0
Thermistor	NA	NA	NA	NA	NA	NA	0
RTD two wires	NA	NA	NA	NA	NA	NA	0
RTD three wires	NA	NA	NA	NA	NA	NA	0
RTD three wires (calibrated)	NA	NA	NA	NA	NA	NA	0
Space heater							
110-127 V	0	0	0	0	0	0	0
220-240 V	0	0	0	0	0	0	0
110-127 / 220-240 V	NA	NA	0	0	0	0	0
380-480 V	0	0	0	0	0	0	0
Insulation class							
F	S	S	S	S	S	S	S
H	0	0	0	0	0	0	0
Forced ventilation kit							
Forced ventilation kit with encoder provision (specify kit voltage)	0	0	0	0	0	0	0
Forced ventilation kit without encoder provision (specify kit voltage)	0	0	0	0	0	0	0
Encoder	0	0	0	0	0	0	0
Drive end side grounding brush	NA	NA	NA	NA	NA	NA	NA
Non drive end side grounding brush	NA	NA	NA	NA	NA	NA	NA
AEGIS SGR™ Bearing Protection Ring Kit	0	0	0	0	0	0	0

Notes: 1) Other optional features, on request.

2) Some combinations of optional features are not allowed – then contact WEG.

S (Standard)

NA (Not available)

O (Optional)

256T	284T	286T	324T	326T	364/5T	404/5T	444/5T	445/7T	447/9T	L447/9T	504/5T	586/7T	588/9T
Painting plan													
0	0	0	0	0	0	0	0	0	0	0	0	0	0
0	0	0	0	0	0	0	0	0	0	0	0	0	0
0	0	0	0	0	0	0	0	0	0	0	0	0	0
0	0	0	0	0	0	0	0	0	0	0	0	0	0
0	0	0	0	0	0	0	0	0	0	0	0	0	0
0	0	0	0	0	0	0	0	0	0	0	0	0	0
0	0	0	0	0	0	0	0	0	0	0	0	0	0
0	0	0	0	0	0	0	0	0	0	0	0	0	0
0	0	0	0	0	0	0	0	0	0	0	0	0	0
Other mechanical optionals													
0	0	0	0	0	0	0	0	0	0	0	0	0	0
0	0	0	0	0	0	0	0	0	0	0	0	0	0
0	0	0	0	0	0	0	0	0	0	0	0	0	0
0	0	0	0	0	0	0	0	0	0	0	0	0	0
Electrical optionals													
Winding thermal protection													
0	0	0	0	0	0	0	0	0	0	0	0	0	0
0	0	0	0	0	0	0	0	0	0	0	0	0	0
0	0	0	0	0	0	0	0	0	0	0	0	0	0
NA	NA	NA	NA	NA	0	0	0	0	0	0	0	0	0
0	0	0	0	0	0	0	0	0	0	0	0	0	0
NA	NA	NA	NA	NA	0	0	0	0	0	0	0	0	0
0	0	0	0	0	0	0	0	0	0	0	0	0	0
0	0	0	0	0	0	0	0	0	0	0	0	0	0
Bearing thermal protection													
0	0	0	0	0	0	0	0	0	0	0	0	0	0
0	0	0	0	0	0	0	0	0	0	0	0	0	0
0	0	0	0	0	0	0	0	0	0	0	0	0	0
0	0	0	0	0	0	0	0	0	0	0	0	0	0
0	0	0	0	0	0	0	0	0	0	0	0	0	0
Space heater													
0	0	0	0	0	0	0	0	0	0	0	0	0	0
0	0	0	0	0	0	0	0	0	0	0	0	S	S
0	0	0	0	0	0	0	0	0	0	0	0	0	0
0	0	0	0	0	0	0	0	0	0	0	0	0	0
Insulation class													
S	S	S	S	S	S	S	S	S	S	S	S	S	S
0	0	0	0	0	0	0	0	0	0	0	0	0	0
Forced ventilation kit													
0	0	0	0	0	0	0	0	0	0	0	0	0	0
0	0	0	0	0	0	0	0	0	0	0	0	0	0
0	0	0	0	0	0	0	0	0	0	0	0	0	0
NA	NA	NA	NA	NA	NA	NA	NA	0	0	NA	0	0	0
NA	NA	NA	NA	NA	0	0	0	0	0	0	0	0	0
0	0	0	0	0	0	0	0	0	0	0	0	0	0

14. Electrical data

W22 - High Efficiency

Output		Rated speed (rpm)	Frame	Full load current In (A)			Locked Rotor Current		Full Load Torque (ft.lb)	Locked Rotor Torque Tl/Tn	Break-down Torque Tb/Tn	Efficiency			Power Factor			Inertia J (lb.ft²)	Allowable locked rotor time (s)		Weight (lb)	Sound dB(A)
HP	kW			At 230 V	At 460 V	At 575 V	Code	l/l/n				% of full load							Hot	Cold		
				50	75	100	50	75				100										
1	0.75	3450	143T	2.96	1.48	1.18	J	6.6	1.50	2.3	2.8	72.0	75.5	75.5	0.69	0.79	0.84	0.0278	26	57	34.2	68
1	0.75	3450	145T	2.96	1.48	1.18	J	6.6	1.50	2.3	2.8	72.0	75.5	75.5	0.69	0.79	0.84	0.0278	26	57	34.2	68
1	0.75	1750	143T	2.88	1.44	1.15	J	6.8	2.96	2.0	3.0	78.5	82.5	82.5	0.60	0.72	0.79	0.0911	20	44	37.5	51
1	0.75	1750	145T	2.88	1.44	1.15	J	6.8	2.96	2.0	3.0	78.5	82.5	82.5	0.60	0.72	0.79	0.0911	20	44	37.5	51
1	0.75	1150	145T	3.26	1.63	1.30	J	5.7	4.51	2.5	2.8	75.5	80.0	80.0	0.50	0.63	0.72	0.1303	23	51	44.1	49
1	0.75	860	182T	4.10	2.05	1.64	K	5.0	6.02	2.0	2.6	68.0	72.0	74.0	0.41	0.52	0.62	0.3481	49	108	88.2	50
1	0.75	860	184T	4.10	2.05	1.64	K	5.0	6.02	2.0	2.6	68.0	72.0	74.0	0.41	0.52	0.62	0.3481	49	108	88.2	50
1.5	1.1	3455	143T	3.98	1.99	1.59	J	6.8	2.25	2.5	3.0	78.5	82.5	82.5	0.68	0.78	0.84	0.0370	17	37	38.6	68
1.5	1.1	3455	145T	3.98	1.99	1.59	J	6.8	2.25	2.5	3.0	78.5	82.5	82.5	0.68	0.78	0.84	0.0370	17	37	38.6	68
1.5	1.1	1740	145T	4.06	2.03	1.62	J	6.8	4.47	2.0	2.7	81.5	84.0	84.0	0.63	0.75	0.81	0.1172	13	29	40.8	51
1.5	1.1	1160	182T	4.48	2.24	1.79	J	6.0	6.70	2.0	2.6	81.5	84.0	85.5	0.53	0.65	0.72	0.4786	55	121	68.4	52
1.5	1.1	1160	184T	4.48	2.24	1.79	J	6.0	6.70	2.0	2.6	81.5	84.0	85.5	0.53	0.65	0.72	0.4786	55	121	68.4	52
1.5	1.1	865	184T	5.44	2.72	2.18	H	4.7	8.98	2.0	2.4	74.0	75.5	77.0	0.44	0.58	0.66	0.3918	37	81	94.8	50
2	1.5	3500	182T	5.16	2.58	2.06	J	7.0	2.96	2.0	3.1	78.5	82.5	84.0	0.74	0.82	0.87	0.1471	55	121	81.6	69
2	1.5	3450	145T	5.28	2.64	2.11	J	6.8	3.00	2.5	3.0	81.5	84.0	84.0	0.69	0.80	0.85	0.0427	16	35	41.9	68
2	1.5	1740	145T	5.46	2.73	2.18	J	6.6	5.96	2.0	2.7	82.5	84.0	84.0	0.64	0.77	0.82	0.1296	11	24	43.0	51
2	1.5	1160	184T	5.96	2.98	2.38	J	6.0	8.93	2.1	2.6	84.0	86.5	86.5	0.54	0.66	0.73	0.5657	47	103	79.4	52
2	1.5	870	213T	6.92	3.46	2.77	L	6.6	11.9	2.4	2.9	78.5	81.5	82.5	0.47	0.53	0.66	1.19	43	95	141	52
3	2.2	3500	182T	7.34	3.67	2.94	H	7.2	4.44	2.0	3.1	82.5	85.5	85.5	0.76	0.84	0.88	0.1645	39	86	84.9	69
3	2.2	3500	184T	7.34	3.67	2.94	H	7.2	4.44	2.0	3.1	82.5	85.5	85.5	0.76	0.84	0.88	0.1645	39	86	84.9	69
3	2.2	3450	145T	7.52	3.76	3.01	H	6.9	4.51	2.8	3.1	85.5	85.5	85.5	0.71	0.81	0.86	0.0610	11	24	51.8	68
3	2.2	1750	182T	7.70	3.85	3.08	J	7.2	8.88	2.2	2.8	86.5	87.5	87.5	0.65	0.76	0.82	0.2636	29	64	83.8	56
3	2.2	1750	184T	7.70	3.85	3.08	J	7.2	8.88	2.2	2.8	86.5	87.5	87.5	0.65	0.76	0.82	0.2636	29	64	83.8	56
3	2.2	1170	213T	8.30	4.15	3.32	H	6.1	13.3	1.8	2.4	84.0	86.5	87.5	0.58	0.70	0.76	0.9933	76	167	110	55
3	2.2	1170	215T	8.30	4.15	3.32	H	6.1	13.3	1.8	2.4	84.0	86.5	87.5	0.58	0.70	0.76	0.9933	76	167	110	55
3	2.2	865	215T	8.66	4.33	3.46	K	7.1	18.0	2.0	2.1	82.5	84.0	84.0	0.59	0.70	0.76	2.02	30	66	159	52
5	3.7	3490	184T	11.8	5.90	4.72	J	7.6	7.42	2.3	3.3	85.5	87.5	87.5	0.80	0.87	0.90	0.1906	27	59	88.2	69
5	3.7	1755	213T	12.6	6.30	5.04	H	6.4	14.8	2.0	2.5	86.5	87.5	87.5	0.68	0.79	0.84	0.8061	20	44	132	58
5	3.7	1745	184T	13.0	6.50	5.20	H	6.6	14.8	2.2	2.7	86.5	87.5	87.5	0.64	0.76	0.82	0.3683	14	31	92.6	56
5	3.7	1165	215T	14.2	7.10	5.68	J	6.4	22.2	2.1	2.3	86.5	87.5	87.5	0.55	0.67	0.75	1.47	35	77	162	55
5	3.7	880	254T	15.5	7.75	6.20	H	5.5	29.4	2.0	2.6	82.5	84.0	85.5	0.48	0.61	0.70	2.90	33	73	243	54
7.5	5.5	3510	213T	17.7	8.85	7.08	H	6.7	11.1	2.1	3.0	87.5	88.5	88.5	0.75	0.84	0.88	0.3842	25	55	128	72
7.5	5.5	3510	215T	17.7	8.85	7.08	H	6.7	11.1	2.1	3.0	87.5	88.5	88.5	0.75	0.84	0.88	0.3842	25	55	128	72
7.5	5.5	3470	184T	17.0	8.50	6.80	H	7.2	11.2	2.2	2.9	87.5	88.5	88.5	0.85	0.90	0.92	0.2288	16	35	92.6	69
7.5	5.5	1755	213T	18.6	9.30	7.44	H	6.5	22.1	2.1	2.6	88.5	89.5	89.5	0.66	0.77	0.83	0.9801	14	31	139	58
7.5	5.5	1755	215T	18.6	9.30	7.44	H	6.5	22.1	2.1	2.6	88.5	89.5	89.5	0.66	0.77	0.83	0.9801	14	31	139	58
7.5	5.5	1175	254T	19.3	9.65	7.72	G	6.1	33.1	2.0	2.7	87.5	88.5	89.5	0.62	0.74	0.80	2.56	23	51	227	59
7.5	5.5	1175	256T	19.3	9.65	7.72	G	6.1	33.1	2.0	2.7	87.5	88.5	89.5	0.62	0.74	0.80	2.56	23	51	227	59
7.5	5.5	880	256T	23.0	11.5	9.20	H	5.5	44.2	2.0	2.6	82.5	85.5	85.5	0.48	0.62	0.70	3.41	25	55	276	54
10	7.5	3500	215T	23.6	11.8	9.44	G	6.5	14.8	2.1	2.8	88.5	89.5	89.5	0.78	0.86	0.89	0.4680	19	42	143	72
10	7.5	1765	254T	25.0	12.5	10.0	G	6.0	29.4	2.1	2.4	88.5	89.5	89.5	0.70	0.80	0.84	1.91	20	44	205	64
10	7.5	1750	215T	25.0	12.5	10.0	G	6.2	29.6	2.0	2.4	89.5	89.5	89.5	0.69	0.80	0.84	1.16	12	26	154	58
10	7.5	1170	254T	26.2	13.1	10.5	G	6.0	44.3	2.0	2.6	88.5	89.5	89.5	0.63	0.75	0.80	2.90	20	44	251	59
10	7.5	1170	256T	26.2	13.1	10.5	G	6.0	44.3	2.0	2.6	88.5	89.5	89.5	0.63	0.75	0.80	2.90	20	44	251	59
10	7.5	880	284T	26.0	13.0	10.4	G	5.7	58.9	2.0	2.2	87.5	88.5	88.5	0.67	0.77	0.82	7.20	30	66	373	54
15	11	3520	254T	34.8	17.4	13.9	G	6.2	22.1	2.0	2.5	89.5	90.2	90.2	0.78	0.86	0.88	1.26	18	40	225	72
15	11	3520	256T	34.8	17.4	13.9	G	6.2	22.1	2.0	2.5	89.5	90.2	90.2	0.78	0.86	0.88	1.26	18	40	225	72
15	11	3490	215T	33.6	16.8	13.4	G	6.3	22.3	2.1	2.5	89.5	90.2	90.2	0.84	0.89	0.91	0.6402	15	33	163	72
15	11	1765	254T	35.6	17.8	14.2	G	6.0	44.0	2.3	2.6	90.2	91.0	91.0	0.68	0.80	0.84	2.38	15	33	227	64
15	11	1765	256T	35.6	17.8	14.2	G	6.0	44.0	2.3	2.6	90.2	91.0	91.0	0.68	0.80	0.84	2.38	15	33	227	64
15	11	1175	284T	35.6	17.8	14.2	G	6.0	66.1	2.2	2.5	90.2	90.2	90.2	0.72	0.81	0.86	7.20	17	37	344	59
15	11	1175	286T	35.6	17.8	14.2	G	6.0	66.1	2.2	2.5	90.2	90.2	90.2	0.72	0.81	0.86	7.20	17	37	344	59
15	11	880	286T	38.0	19.0	15.2	G	5.7	88.3	2.0	2.2	87.5	88.5	88.5	0.68	0.78	0.82	8.18	22	48	417	54
20	15	3520	254T	47.4	23.7	19.0	G	6.0	29.4	2.0	2.5	90.2	90.2	90.2	0.78	0.85	0.88	1.54	15	33	265	72
20	15	3520	256T	47.4	23.7	19.0	G	6.0	29.4	2.0	2.5	90.2	90.2	90.2	0.78	0.85	0.88	1.54	15	33	265	72
20	15	1760	256T	48.6	24.3	19.4	G	6.0	58.9	2.0	2.4	90.2	91.0	91.0	0.72	0.81	0.85	2.86	14	31	262	64
20	15	1760	284T	48.2	24.1	19.3	G	6.0	58.9	2.0	2.3	91.0	91.0	91.0	0.74	0.82	0.86	5.11	27	59	344	64
20	15	1175	286T	48.2	24.1	19.3	G	6.1	88.2	2.1	2.4	90.2	91.0	91.0	0.73	0.82	0.86	8.18	16	35	390	59
20	15	880	324T	56.8	28.4	22.7	G	5.0	118	2.0	2.2	87.5	89.5	89.5	0.55	0.67	0.74	9.79	24	53	452	56
20	15	880	326T	56.8	28.4	22.7	G	5.0	118	2.0	2.2	87.5	89.5	89.5	0.55	0.67	0.74	9.79	24	53	452	56

W22 - High Efficiency

Output		Rated speed (rpm)	Frame	Full load current In (A)			Locked Rotor Current		Full Load Torque (ft.lb)	Locked Rotor Torque Tl/Tn	Break-down Torque Tb/Tn	Efficiency			Power Factor			Inertia J (lb.ft ²)	Allowable locked rotor time (s)		Weight (lb)	Sound dB(A)			
HP	kW			At 230 V	At 460 V	At 575 V	Code	I _L /I _n				% of full load			50	75	100		50	75			100	Hot	Cold
												50	75	100											
25	18.5	3530	284TS	58.0	29.0	23.2	F	6.0	36.7	2.0	2.4	91.0	91.0	91.0	0.83	0.88	0.90	2.29	15	33	344	72			
25	18.5	3530	286TS	58.0	29.0	23.2	F	6.0	36.7	2.0	2.4	91.0	91.0	91.0	0.83	0.88	0.90	2.29	15	33	344	72			
25	18.5	3515	256T	56.8	28.4	22.7	G	6.2	36.8	2.0	2.3	91.0	91.0	91.0	0.81	0.87	0.90	1.54	11	24	273	72			
25	18.5	1760	284T	58.4	29.2	23.4	F	6.0	73.6	2.2	2.4	91.7	92.4	92.4	0.73	0.82	0.86	5.11	23	51	388	64			
25	18.5	1760	286T	58.4	29.2	23.4	F	6.0	73.6	2.2	2.4	91.7	92.4	92.4	0.73	0.82	0.86	5.11	23	51	388	64			
25	18.5	1175	324T	61.0	30.5	24.4	F	5.7	110	2.0	2.4	91.0	91.7	91.7	0.69	0.79	0.83	10.2	19	42	448	62			
25	18.5	1175	326T	61.0	30.5	24.4	F	5.7	110	2.0	2.4	91.0	91.7	91.7	0.69	0.79	0.83	10.2	19	42	448	62			
25	18.5	880	326T	71.0	35.5	28.4	G	5.1	147	2.2	2.3	87.5	89.5	89.5	0.53	0.66	0.73	11.9	19	42	509	56			
30	22	3530	284TS	67.4	33.7	27.0	F	6.0	44.0	2.0	2.4	91.0	91.0	91.0	0.82	0.88	0.90	2.83	14	31	375	72			
30	22	3530	286TS	67.4	33.7	27.0	F	6.0	44.0	2.0	2.4	91.0	91.0	91.0	0.82	0.88	0.90	2.83	14	31	375	72			
30	22	1760	286T	68.6	34.3	27.4	F	6.0	88.3	2.3	2.4	92.4	93.0	92.4	0.74	0.83	0.87	5.32	19	42	419	64			
30	22	1175	326T	71.6	35.8	28.6	F	5.8	132	2.0	2.4	91.0	91.7	91.7	0.69	0.79	0.84	11.9	18	40	492	62			
30	22	880	364/5T	74.0	37.0	29.6	G	6.0	177	1.6	2.2	91.0	91.7	91.0	0.67	0.77	0.82	23.5	17	37	776	60			
40	30	3550	324TS	92.2	46.1	36.9	F	6.0	58.4	2.1	2.3	91.0	91.7	91.7	0.83	0.88	0.89	4.90	22	48	516	76			
40	30	3550	326TS	92.2	46.1	36.9	F	6.0	58.4	2.1	2.3	91.0	91.7	91.7	0.83	0.88	0.89	4.90	22	48	516	76			
40	30	3530	286TS	91.2	45.6	36.5	G	6.2	58.7	2.1	2.5	91.7	91.7	91.7	0.82	0.88	0.90	2.83	10	22	410	72			
40	30	1770	324T	95.2	47.6	38.1	G	6.0	117	2.1	2.4	92.4	93.0	93.0	0.74	0.82	0.85	7.85	18	40	463	68			
40	30	1770	326T	95.2	47.6	38.1	G	6.0	117	2.1	2.4	92.4	93.0	93.0	0.74	0.82	0.85	7.85	18	40	463	68			
40	30	1180	364/5T	94.2	47.1	37.7	G	6.2	176	1.9	2.3	93.0	93.0	93.0	0.74	0.83	0.86	23.5	16	35	770	64			
40	30	880	364/5T	101	50.5	40.4	G	6.0	235	1.7	2.2	91.0	91.7	91.0	0.67	0.77	0.82	29.0	13	29	831	60			
40	30	880	404/5T	100	50.0	40.0	G	6.0	235	1.7	2.3	91.0	91.7	91.0	0.69	0.79	0.83	29.0	15	33	933	60			
50	37	3555	324TS	113	56.5	45.2	F	6.2	72.9	2.3	2.3	91.7	92.4	92.4	0.83	0.88	0.89	5.32	18	40	549	76			
50	37	3555	326TS	113	56.5	45.2	F	6.2	72.9	2.3	2.3	91.7	92.4	92.4	0.83	0.88	0.89	5.32	18	40	549	76			
50	37	3550	364/5TS	112	56.0	44.8	G	6.3	73.0	1.9	2.4	91.0	92.4	92.4	0.83	0.88	0.90	8.51	17	37	763	80			
50	37	1770	326T	116	58.0	46.4	F	6.0	146	2.2	2.4	93.0	93.6	93.0	0.74	0.82	0.86	9.16	15	33	512	68			
50	37	1770	364/5T	115	57.5	46.0	F	6.0	146	1.9	2.2	93.0	93.0	93.0	0.79	0.85	0.87	17.4	15	33	754	70			
50	37	1180	364/5T	116	58.0	46.4	G	6.2	220	1.9	2.3	93.0	93.0	93.0	0.75	0.83	0.86	29.0	15	33	816	64			
50	37	880	404/5T	122	61.0	48.8	G	6.2	294	1.7	2.4	91.7	91.7	91.7	0.70	0.79	0.83	34.6	12	26	992	60			
60	45	3550	326TS	138	69.0	55.2	F	6.0	87.6	2.1	2.3	92.4	93.0	93.0	0.82	0.87	0.88	5.32	17	37	584	76			
60	45	3550	364/5TS	135	67.5	54.0	G	6.3	87.6	2.0	2.4	91.7	93.0	93.0	0.84	0.89	0.90	8.51	15	33	807	80			
60	45	3550	404/5TS	135	67.5	54.0	F	6.2	87.6	1.9	2.4	91.7	92.4	93.0	0.84	0.89	0.90	8.51	19	42	882	80			
60	45	1770	326T	142	71.0	56.8	G	6.0	176	2.1	2.4	93.0	93.6	93.6	0.73	0.81	0.85	9.16	14	31	595	68			
60	45	1770	364/5T	139	69.5	55.6	G	6.3	176	2.0	2.3	93.6	93.6	93.6	0.79	0.85	0.87	17.4	12	26	800	70			
60	45	1180	404/5T	140	70.0	56.0	G	6.1	263	2.0	2.3	93.6	93.6	93.6	0.75	0.83	0.86	34.6	16	35	1005	64			
60	45	880	404/5T	148	74.0	59.2	G	6.3	353	1.8	2.5	91.7	92.4	91.7	0.70	0.80	0.83	36.9	11	24	1047	60			
75	55	3550	364/5TS	165	82.5	66.0	G	6.4	109	2.0	2.4	93.0	93.0	93.0	0.86	0.89	0.90	10.6	14	31	847	80			
75	55	1775	404/5T	167	83.5	66.8	F	6.3	219	2.0	2.5	94.1	94.1	94.1	0.79	0.86	0.88	19.9	15	33	950	70			
75	55	1770	364/5T	169	84.5	67.6	G	6.3	220	2.1	2.4	94.1	94.1	94.1	0.79	0.85	0.87	19.9	10	22	847	70			
75	55	1185	444/5T	178	89.0	71.2	G	6.0	328	2.0	2.2	93.6	94.1	93.6	0.70	0.80	0.83	62.7	19	42	1338	69			
75	55	1180	404/5T	172	86.0	68.8	F	6.1	329	2.0	2.2	93.6	93.6	93.6	0.76	0.84	0.86	36.9	13	29	1054	64			
75	55	885	444/5T	186	93.0	74.4	F	5.6	439	1.7	2.0	93.0	93.0	93.0	0.67	0.76	0.80	73.6	20	44	1444	63			
100	75	3570	444/5TS	228	114	91.2	G	6.3	145	1.7	2.4	92.4	93.6	93.6	0.78	0.85	0.88	27.9	30	66	1389	81			
100	75	3550	364/5TS	226	113	90.4	G	6.4	146	2.0	2.4	93.6	94.1	93.6	0.84	0.88	0.89	11.9	11	24	889	80			
100	75	3550	404/5TS	224	112	89.6	G	6.4	146	2.0	2.4	93.6	94.1	93.6	0.85	0.89	0.90	11.9	11	24	1008	80			
100	75	1780	444/5T	234	117	93.6	G	6.2	291	1.8	2.4	94.1	94.5	94.5	0.74	0.82	0.85	33.1	24	53	1367	73			
100	75	1775	404/5T	224	112	89.6	F	6.1	292	2.1	2.4	94.5	94.5	94.5	0.82	0.87	0.89	27.4	14	31	1094	70			
100	75	1185	444/5T	242	121	96.8	G	6.0	437	2.0	2.2	94.1	94.1	94.1	0.70	0.80	0.83	73.6	16	35	1422	69			
100	75	1185	445/7T	242	121	96.8	G	6.0	437	2.0	2.2	94.1	94.1	94.1	0.70	0.80	0.83	73.6	16	35	1466	69			
100	75	885	444/5T	254	127	102	G	5.7	585	1.8	2.0	93.0	93.6	93.0	0.67	0.76	0.80	87.3	18	40	1599	63			
100	75	885	445/7T	254	127	102	G	5.7	585	1.8	2.0	93.0	93.6	93.0	0.67	0.76	0.80	87.3	18	40	1643	63			
125	90	3570	444/5TS	272	136	109	F	6.2	181	1.8	2.4	93.0	94.1	94.5	0.80	0.86	0.88	27.9	24	53	1464	81			
125	90	1780	444/5T	278	139	111	F	6.1	364	1.8	2.4	94.5	94.5	94.5	0.77	0.84	0.86	45.7	24	53	1444	73			
125	90	1185	444/5T	286	143	114	F	6.0	547	2.0	2.2	94.1	94.5	94.1	0.72	0.80	0.84	87.3	19	42	1599	69			
125	90	890	504/5T	302	151	121	F	5.8	728	1.8	2.0	93.6	94.1	93.6	0.67	0.76	0.80	104	23	51	2110	66			
125	90	885	445/7T	302	151	121	F	5.8	732	1.8	2.0	93.6	94.1	93.6	0.67	0.76	0.80	104	15	33	1806	63			
150	110	3570	444/5TS	328	164	131	F	6.3	218	1.9	2.4	94.1	95.0	94.5	0.82	0.87	0.89	33.5	23	51	1610	81			
150	110	1790	504/5T	338	169	135	F	6.2	434	1.9	2.3	93.6	94.5	95.0	0.76	0.83	0.86	57.2	28	62	1890	75			
150	110	1780	444/5T	334	167	134	F	6.3	437	1.9	2.4	95.0	95.0	95.0	0.78	0.84	0.87	57.2	23	51	1552	73			
150	110	1190	504/5T	350	175	140	G	6.2	653	2.0	2.2	94.1	95.0	95.0	0.71	0.80	0.83	109	22	48	2097	70			
150	110	1185	445/7T	346	173	138	G	6.1	656	2.0	2.2	94.5	95.0	95.0	0.73	0.80	0.84	109	19	42	1810	69			
150	110	890	504/5T	362	181	145	F	5.8	873	1.8	2.0	94.1	94.5	94.1	0.68	0									

W22 - High Efficiency

Output		Rated speed (rpm)	Frame	Full load current In (A)			Locked Rotor Current		Full Load Torque (ft.lb)	Locked Rotor Torque Tl/Tn	Break-down Torque Tb/Tn	Efficiency			Power Factor			Inertia J (lb.ft2)	Allowable locked rotor time (s)		Weight (lb)	Sound dB(A)
HP	kW			At 230 V	At 460 V	At 575 V	Code	l/In				% of full load			50	75	100		50	75		
200	150	3575	504/5TS	438	219	175	G	6.6	290	2.0	2.5	94.1	95.0	95.4	0.82	0.88	0.90	44.7	24	53	2168	81
200	150	3565	445/7TS	446	223	178	G	6.5	291	2.0	2.2	94.5	95.0	95.0	0.86	0.88	0.89	44.7	18	40	1914	81
200	150	1785	504/5T	460	230	184	G	6.2	580	2.0	2.1	94.5	95.0	95.0	0.77	0.84	0.86	76.2	21	46	2145	75
200	150	1780	444/5T	460	230	184	G	6.4	582	2.0	2.3	95.0	95.4	95.0	0.77	0.84	0.86	76.2	18	40	1828	73
200	150	1780	445/7T	460	230	184	G	6.4	582	2.0	2.3	95.0	95.4	95.0	0.77	0.84	0.86	76.2	18	40	1828	73
200	150	1190	504/5T	472	236	189	G	6.0	871	2.0	2.1	95.0	95.0	95.0	0.73	0.81	0.84	134	19	42	2368	70
200	150	1185	445/7T	472	236	189	G	6.1	874	2.1	2.2	94.5	95.0	95.0	0.72	0.81	0.84	134	15	33	2093	69
200	150	895	586/7T	498	249	199	G	6.0	1160	1.3	2.1	95.0	95.0	94.5	0.65	0.76	0.80	350	40	88	3334	75
200	150	890	447/9T	504	252	202	G	5.9	1160	1.9	2.1	94.1	94.5	94.5	0.65	0.75	0.79	161	14	31	2430	63
250	185	3575	447/9TS	540	270	216	F	6.5	362	1.9	2.4	94.5	95.4	95.4	0.85	0.88	0.90	51.4	20	44	2388	81
250	185	3575	504/5TS	540	270	216	F	6.5	362	1.9	2.4	94.5	95.4	95.4	0.85	0.88	0.90	51.4	20	44	2388	81
250	185	3570	445/7TS	540	270	216	F	6.5	363	2.2	2.2	95.0	95.4	95.4	0.87	0.89	0.90	51.4	18	40	2159	81
250	185	1785	504/5T	566	283	226	G	6.4	726	2.1	2.1	95.0	95.4	95.4	0.77	0.84	0.86	89.6	21	46	2337	75
250	185	1780	445/7T	566	283	226	G	6.4	728	2.2	2.2	95.0	95.4	95.4	0.78	0.84	0.86	89.6	16	35	2033	73
250	185	1780	447/9T	566	283	226	G	6.4	728	2.2	2.2	95.0	95.4	95.4	0.78	0.84	0.86	89.6	16	35	2033	73
250	185	1190	586/7T	596	298	238	G	6.1	1090	2.0	2.1	95.0	95.4	95.0	0.69	0.78	0.82	226	30	66	3206	77
250	185	1185	447/9T	582	291	233	G	6.2	1090	2.2	2.2	95.0	95.4	95.0	0.71	0.80	0.84	153	11	24	2452	69
250	185	895	586/7T	604	302	242	G	6.0	1450	1.3	2.1	95.0	95.4	95.0	0.67	0.77	0.81	387	40	88	3649	75
300	220	3580	586/7TS	636	318	254	F	6.5	434	1.6	2.2	95.0	95.4	95.4	0.87	0.90	0.91	123	30	66	3382	84
300	220	3575	447/9TS	644	322	258	F	6.5	435	2.5	2.4	95.4	95.4	95.4	0.86	0.89	0.90	58.1	14	31	2545	81
300	220	1790	586/7T	678	339	271	G	6.4	868	1.9	2.2	95.0	95.4	95.8	0.76	0.83	0.85	163	20	44	2961	81
300	220	1780	447/9T	674	337	270	G	6.5	873	2.3	2.3	95.4	95.8	95.4	0.76	0.84	0.86	105	14	31	2375	73
300	220	1190	586/7T	714	357	286	G	6.0	1310	2.0	2.0	95.0	95.4	95.4	0.69	0.78	0.81	277	30	66	3495	77
300	220	1185	447/9T	700	350	280	H	6.9	1310	2.4	2.4	95.0	95.4	95.0	0.69	0.79	0.83	169	10	22	2613	69
300	220	895	586/7T	718	359	287	G	6.4	1740	1.5	2.2	95.0	95.4	95.0	0.66	0.77	0.81	462	40	88	4035	75
350	260	3580	586/7TS	748	374	299	F	6.5	507	1.6	2.4	95.4	95.8	95.8	0.87	0.90	0.91	136	25	55	3621	84
350	260	3575	447/9TS	756	378	302	J	8.5	507	2.5	2.6	95.4	95.8	95.8	0.85	0.89	0.90	68.1	10	22	2701	81
350	260	1785	586/7T	792	396	317	G	6.3	1020	1.9	2.0	95.4	95.8	95.8	0.77	0.84	0.86	179	22	48	3213	81
350	260	1780	447/9T	792	396	317	G	6.4	1020	2.1	2.2	95.4	95.8	95.8	0.76	0.84	0.86	118	16	35	2644	73
350	260	1190	586/7T	844	422	338	G	6.1	1520	1.8	2.1	95.0	95.4	95.4	0.66	0.77	0.81	328	29	64	3784	77
350	260	895	586/7T	858	429	343	H	6.7	2030	1.6	2.3	95.0	95.4	95.0	0.64	0.75	0.80	484	34	75	4309	75
400	300	3580	586/7TS	864	432	346	F	6.5	579	1.8	2.2	95.4	95.8	95.8	0.88	0.90	0.91	122	48	106	3749	84
400	300	1790	586/7T	914	457	366	G	6.4	1160	2.0	2.2	95.4	95.8	95.8	0.77	0.84	0.86	179	19	42	3455	81
400	300	1190	586/7T	974	487	390	G	6.1	1740	2.2	2.1	95.0	95.4	95.4	0.67	0.77	0.81	368	29	64	4115	77
450	330	3580	586/7TS	950	475	380	F	6.6	651	2.0	2.3	95.4	95.8	95.8	0.88	0.90	0.91	132	36	79	3918	84
450	330	1790	586/7T	1010	505	404	G	6.4	1300	2.1	2.1	95.4	95.8	95.8	0.77	0.84	0.86	213	17	37	3455	81
450	330	1190	586/7T	1070	535	428	G	6.1	1960	2.1	2.1	95.0	95.4	95.4	0.67	0.77	0.81	368	26	57	4384	77
500	370*	3580	586/7TS	1070	535	428	G	6.8	724	2.2	2.4	95.4	95.8	95.8	0.88	0.90	0.91	143	39	86	4086	84
500	370*	1790	586/7T	1130	565	452	G	6.4	1450	2.1	2.0	95.4	95.8	95.8	0.79	0.85	0.86	256	16	35	3912	81
500	370*	1190	586/7T	1210	605	484	G	6.3	2180	2.2	2.1	95.4	95.8	95.8	0.66	0.76	0.80	368	25	55	4403	77

Note:
 (*) Fitted with air deflector in the drive end side.



W22 - NEMA Premium Efficiency

Output		Rated speed (rpm)	Frame	Full load current In (A)			Locked Rotor Current		Full Load Torque (ft.lb)	Locked Rotor Torque Tl/Tn	Break-down Torque Tb/Tn	Efficiency			Power Factor			Inertia J (lb.ft ²)	Allowable locked rotor time (s)		Weight (lb)	Sound dB(A)
HP	kW			At 230 V	At 460 V	At 575 V	Code	I/In				% of full load							Hot	Cold		
												50	75	100	50	75	100					
1	0.75	3495	143T	2.86	1.43	1.14	L	8.2	1.48	2.8	3.4	74.0	77.0	78.5	0.69	0.79	0.84	0.0332	22	48	36.4	68.0
1	0.75	1760	143T	2.82	1.41	1.13	L	8.4	2.94	2.3	3.5	80.0	84.0	85.5	0.60	0.70	0.78	0.1172	18	40	40.8	51.0
1	0.75	1760	145T	2.82	1.41	1.13	L	8.4	2.94	2.3	3.5	80.0	84.0	85.5	0.60	0.70	0.78	0.1172	18	40	40.8	51.0
1	0.75	1150	145T	3.45	1.73	1.38	K	6.2	4.51	3.0	3.0	77.0	82.0	82.5	0.45	0.57	0.66	0.1595	28	62	52.9	49.0
1	0.75	875	182T	4.60	2.30	1.84	M	6.0	5.92	3.0	3.5	74.0	77.0	78.5	0.32	0.42	0.52	0.3991	22	48	94.8	50.0
1.5	1.1	3490	143T	3.82	1.91	1.53	L	8.9	2.23	3.5	3.8	81.5	84.0	84.0	0.72	0.82	0.86	0.0470	21	46	40.8	68.0
1.5	1.1	3490	145T	3.82	1.91	1.53	L	8.9	2.23	3.5	3.8	81.5	84.0	84.0	0.72	0.82	0.86	0.0470	21	46	40.8	68.0
1.5	1.1	1755	145T	4.04	2.02	1.62	K	8.3	4.43	2.4	3.4	82.5	85.5	86.5	0.60	0.70	0.79	0.1431	14	31	48.5	51.0
1.5	1.1	1165	182T	4.78	2.39	1.91	M	8.0	6.67	3.2	4.0	84.0	86.5	87.5	0.45	0.56	0.66	0.4879	16	35	70.3	52.0
1.5	1.1	860	184T	5.40	2.70	2.16	J	5.5	9.04	2.5	2.6	80.0	82.5	85.5	0.43	0.54	0.62	0.5766	17	37	111	50.0
2	1.5	3530	182T	5.24	2.62	2.10	M	9.8	2.94	2.9	4.8	78.5	84.0	85.5	0.68	0.79	0.84	0.1718	47	103	86.0	69.0
2	1.5	3480	145T	5.06	2.53	2.02	K	8.7	2.98	3.5	3.8	82.5	85.5	85.5	0.73	0.82	0.87	0.0605	17	37	51.8	68.0
2	1.5	1750	145T	5.22	2.61	2.09	J	7.5	5.92	2.1	3.0	84.0	86.5	86.5	0.66	0.78	0.84	0.1561	11	24	50.7	51.0
2	1.5	1165	184T	6.45	3.23	2.58	L	7.5	8.89	3.0	3.0	86.5	88.5	88.5	0.46	0.58	0.66	0.6210	31	68	87.5	52.0
2	1.5	870	213T	6.78	3.39	2.71	M	7.6	11.9	2.4	2.9	82.5	84.0	85.5	0.45	0.55	0.65	1.79	39	86	149	52.0
3	2.2	3460	145T	7.42	3.71	2.97	J	8.1	4.49	3.3	3.6	85.5	86.5	86.5	0.70	0.81	0.86	0.0605	14	31	51.8	68.0
3	2.2	3510	182T	7.26	3.63	2.90	K	8.3	4.43	2.4	3.8	82.5	86.5	86.5	0.75	0.84	0.88	0.1889	41	90	88.2	69.0
3	2.2	3510	184T	7.26	3.63	2.90	K	8.3	4.43	2.4	3.8	82.5	86.5	86.5	0.75	0.84	0.88	0.1889	41	90	88.2	69.0
3	2.2	1760	182T	7.76	3.88	3.10	K	8.1	8.83	2.3	3.4	86.5	88.5	89.5	0.61	0.73	0.79	0.3401	23	51	90.4	56.0
3	2.2	1760	184T	7.76	3.88	3.10	K	8.1	8.83	2.3	3.4	86.5	88.5	89.5	0.61	0.73	0.79	0.3401	23	51	90.4	56.0
3	2.2	1170	213T	8.83	4.41	3.53	K	7.0	13.3	2.0	2.8	86.5	88.5	89.5	0.50	0.63	0.70	1.20	58	128	121	55.0
3	2.2	865	215T	9.12	4.56	3.65	K	6.8	18.0	2.3	2.8	84.0	85.5	85.5	0.50	0.63	0.71	2.11	44	97	176	52.0
5	3.7	3500	184T	11.8	5.90	4.72	K	8.7	7.40	2.7	3.9	86.5	88.5	88.5	0.76	0.85	0.89	0.2233	25	55	88.2	69.0
5	3.7	1755	184T	12.9	6.45	5.16	J	7.5	14.8	2.3	3.2	88.5	89.5	89.5	0.62	0.74	0.80	0.4003	15	33	94.8	56.0
5	3.7	1160	215T	13.7	6.83	5.46	J	6.6	22.3	1.9	2.4	88.5	89.5	89.5	0.58	0.70	0.76	1.47	57	125	162	55.0
5	3.7	880	254T	15.2	7.58	6.06	H	5.3	29.4	1.9	2.5	85.5	87.5	87.5	0.49	0.62	0.70	3.41	44	97	258	54.0
7.5	5.5	3520	213T	17.5	8.76	7.01	H	7.2	11.0	2.1	3.0	87.5	89.5	89.5	0.75	0.84	0.88	0.4665	27	59	139	72.0
7.5	5.5	3520	215T	17.5	8.76	7.01	H	7.2	11.0	2.1	3.0	87.5	89.5	89.5	0.75	0.84	0.88	0.4665	27	59	139	72.0
7.5	5.5	3485	184T	17.5	8.76	7.01	J	8.2	11.1	2.7	3.3	88.5	89.5	89.5	0.75	0.84	0.88	0.2242	17	37	92.6	69.0
7.5	5.5	1765	213T	18.0	9.00	7.20	H	7.1	22.0	2.2	3.1	89.5	91.0	91.0	0.67	0.78	0.84	1.34	20	44	154	58.0
7.5	5.5	1765	215T	18.0	9.00	7.20	H	7.1	22.0	2.2	3.1	89.5	91.0	91.0	0.67	0.78	0.84	1.34	20	44	154	58.0
7.5	5.5	1175	254T	19.0	9.48	7.58	H	6.8	33.1	2.5	3.0	89.5	90.2	91.0	0.63	0.74	0.80	3.92	30	66	262	59.0
7.5	5.5	880	256T	22.2	11.1	8.88	G	5.3	44.2	2.0	2.5	85.5	87.5	87.5	0.50	0.63	0.71	4.43	33	73	284	54.0
7.5	5.5	880	284T	20.0	10.0	8.00	G	5.6	44.2	2.0	2.4	87.5	88.5	88.5	0.60	0.72	0.78	7.20	34	75	344	54.0
10	7.5	3515	215T	23.2	11.6	9.28	H	7.2	14.7	2.1	2.9	89.5	90.2	90.2	0.79	0.87	0.90	0.6362	24	53	163	72.0
10	7.5	1760	215T	24.8	12.4	9.92	H	6.4	29.4	2.0	3.0	90.2	91.7	91.7	0.66	0.77	0.83	1.51	17	37	172	58.0
10	7.5	1175	254T	25.8	12.9	10.3	H	6.5	44.1	2.3	2.8	90.2	91.0	91.0	0.63	0.74	0.80	4.43	26	57	289	59.0
10	7.5	1175	256T	25.8	12.9	10.3	H	6.5	44.1	2.3	2.8	90.2	91.0	91.0	0.63	0.74	0.80	4.43	26	57	289	59.0
10	7.5	880	284T	26.8	13.4	10.7	G	5.6	58.9	2.0	2.4	89.5	90.2	90.2	0.61	0.72	0.78	7.20	32	70	373	54.0
15	11	3530	254T	34.4	17.2	13.8	G	6.8	22.0	2.2	2.7	89.5	91.0	91.0	0.77	0.85	0.88	1.26	25	55	236	72.0
15	11	3510	215T	34.0	17.0	13.6	H	7.6	22.1	2.4	2.8	90.2	91.0	91.0	0.76	0.85	0.89	0.6362	14	31	163	72.0
15	11	1765	254T	36.0	18.0	14.4	H	7.0	44.0	2.3	2.7	91.0	91.7	92.4	0.68	0.78	0.83	2.62	17	37	251	64.0
15	11	1765	256T	36.0	18.0	14.4	H	7.0	44.0	2.3	2.7	91.0	91.7	92.4	0.68	0.78	0.83	2.62	17	37	251	64.0
15	11	1175	284T	35.8	17.9	14.3	G	6.6	66.1	2.3	2.7	91.0	91.7	91.7	0.69	0.80	0.84	7.85	20	44	379	59.0
15	11	1175	286T	35.8	17.9	14.3	G	6.6	66.1	2.3	2.7	91.0	91.7	91.7	0.69	0.80	0.84	7.85	20	44	379	59.0
15	11	880	286T	38.8	19.4	15.5	G	5.5	88.3	2.0	2.3	90.2	91.0	90.2	0.62	0.73	0.79	8.18	25	55	417	54.0
20	15	3520	256T	46.4	23.2	18.6	F	6.0	29.4	2.0	2.4	91.0	91.7	91.0	0.82	0.87	0.89	1.54	21	46	269	72.0
20	15	1765	256T	48.2	24.1	19.3	H	6.6	58.7	2.3	2.7	91.7	92.4	93.0	0.68	0.79	0.84	3.10	15	33	291	64.0
20	15	1765	284T	48.2	24.1	19.3	G	6.4	58.7	2.3	2.6	92.4	93.0	93.0	0.70	0.80	0.84	5.11	27	59	370	64.0
20	15	1175	286T	48.4	24.2	19.4	G	6.4	88.2	2.3	2.6	91.0	91.7	91.7	0.70	0.80	0.85	9.16	16	35	426	59.0
20	15	880	324T	56.6	28.3	22.6	G	5.0	118	1.9	2.2	89.5	91.0	91.0	0.54	0.66	0.73	9.37	27	59	452	56.0
25	18.5	3535	284TS	57.0	28.5	22.8	G	6.3	36.6	2.0	2.5	91.0	91.7	91.7	0.82	0.87	0.89	2.69	17	37	362	72.0
25	18.5	1765	284T	59.0	29.5	23.6	G	6.7	73.4	2.4	2.7	92.4	93.0	93.6	0.70	0.80	0.84	5.11	24	53	388	64.0
25	18.5	1765	286T	59.0	29.5	23.6	G	6.7	73.4	2.4	2.7	92.4	93.0	93.6	0.70	0.80	0.84	5.11	24	53	388	64.0
25	18.5	1180	324T	60.8	30.4	24.3	G	6.2	110	2.1	2.6	91.7	93.0	93.0	0.65	0.77	0.82	11.5	26	57	560	62.0
25	18.5	1180	326T	60.8	30.4	24.3	G	6.2	110	2.1	2.6	91.7	93.0	93.0	0.65	0.77	0.82	11.5	26	57	560	62.0
25	18.5	880	326T	71.8	35.9	28.7	G	5.2	147	2.0	2.3	89.5	91.0	91.0	0.51	0.64	0.71	11.9	23	51	509	56.0
30	22	3535	286TS	67.6	33.8	27.0	G	6.3	44.0	2.0	2.5	91.7	91.7	91.7	0.82	0.87	0.89	3.37	15	33	392	72.0
30	22	1775	324T	70.2	35.1	28.1	G	6.4	87.6	2.1	2.6	92.4	93.6	93.6	0.70	0.79	0.84	8.18	26	57	463	66.0
30	22	1765	286T	70.2	35.1	28.1	G	6.4	88.1	2.4	2.7	93.0	93.0	93.6	0.70	0.80	0.8					



W22 - NEMA Premium Efficiency

Output		Rated speed (rpm)	Frame	Full load current In (A)			Locked Rotor Current		Full Load Torque (ft.lb)	Locked Rotor Torque Tl/Tn	Break-down Torque Tlb/Tn	Efficiency % of full load			Power Factor			Inertia J (lb.ft ²)	Allowable locked rotor time (s)		Weight (lb)	Sound dB(A)
				At 230 V	At 460 V	At 575 V	Code	I/In				50	75	100	50	75	100		Hot	Cold		
40	30	3555	324TS	91.6	45.8	36.6	G	6.4	58.3	2.3	2.4	91.7	92.4	92.4	0.82	0.87	0.89	4.90	22	48	547	74.0
40	30	1775	324T	96.4	48.2	38.6	J	7.4	117	2.2	2.6	93.0	94.1	94.1	0.67	0.78	0.83	9.16	20	44	492	66.0
40	30	1775	326T	96.4	48.2	38.6	J	7.4	117	2.2	2.6	93.0	94.1	94.1	0.67	0.78	0.83	9.16	20	44	492	66.0
40	30	1180	364/5T	93.0	46.5	37.2	G	6.4	176	2.0	2.4	93.6	93.6	94.1	0.73	0.82	0.86	29.0	21	46	833	66.0
40	30	880	364/5T	100	50.0	40.0	G	6.0	235	1.7	2.3	92.4	93.0	92.4	0.66	0.76	0.81	29.0	18	40	875	60.0
50	37	3550	326TS	112	56.1	44.9	F	6.2	73.0	2.2	2.3	93.0	93.0	93.0	0.83	0.87	0.89	5.75	23	51	584	74.0
50	37	1775	326T	118	59.2	47.4	H	6.7	146	2.3	2.7	93.0	94.1	94.5	0.66	0.77	0.83	9.16	15	33	536	66.0
50	37	1180	364/5T	115	57.4	45.9	G	6.4	220	2.0	2.4	93.6	94.1	94.1	0.74	0.83	0.86	32.4	18	40	869	66.0
50	37	1180	404/5T	116	58.1	46.5	G	6.3	220	2.0	2.4	93.6	94.1	94.1	0.73	0.82	0.85	32.4	20	44	975	68.0
50	37	880	404/5T	120	60.0	48.0	G	6.5	294	1.7	2.6	93.0	93.0	93.0	0.68	0.78	0.83	34.6	15	33	1012	60.0
60	45	3560	364/5TS	134	67.0	53.6	G	6.6	87.3	2.0	2.6	91.7	93.0	93.6	0.81	0.88	0.90	10.6	14	31	825	79.0
60	45	3555	404/5TS	134	67.0	53.6	G	6.5	87.4	2.0	2.5	91.7	93.0	93.6	0.82	0.88	0.90	10.6	22	48	911	79.0
60	45	1775	364/5T	137	68.3	54.6	G	6.6	175	2.4	2.6	94.1	94.5	95.0	0.75	0.83	0.87	22.4	15	33	869	67.0
60	45	1180	404/5T	139	69.5	55.6	G	6.4	263	2.0	2.3	94.1	94.5	94.5	0.74	0.82	0.86	36.9	20	44	1036	68.0
60	45	880	404/5T	146	73.0	58.4	H	6.5	353	1.8	2.7	93.0	93.0	93.0	0.68	0.78	0.83	40.2	13	29	1111	60.0
75	55	3555	364/5TS	164	81.9	65.5	G	6.6	109	2.0	2.6	92.4	93.6	93.6	0.83	0.88	0.90	11.9	10	22	847	79.0
75	55	1775	364/5T	168	84.1	67.3	G	7.0	219	2.4	2.6	94.5	95.0	95.4	0.73	0.82	0.86	23.3	14	31	919	67.0
75	55	1180	404/5T	170	84.9	67.9	G	6.4	329	2.0	2.3	94.1	94.5	94.5	0.74	0.83	0.86	40.2	17	37	1089	68.0
75	55	890	444/5T	186	93.0	74.4	G	6.0	437	1.8	2.1	93.0	93.6	93.6	0.64	0.74	0.79	73.6	18	40	1444	63.0
100	75	3555	404/5TS	220	110	88.0	G	6.5	146	2.0	2.4	93.0	94.1	94.1	0.85	0.90	0.91	13.2	14	31	1045	79.0
100	75	1775	404/5T	222	111	88.8	G	6.6	292	2.4	2.6	95.0	95.0	95.4	0.78	0.86	0.89	29.9	13	29	1140	68.0
100	75	1185	444/5T	242	121	96.8	G	6.4	437	2.2	2.6	94.5	95.0	95.0	0.68	0.78	0.82	87.3	20	44	1577	69.0
100	75	890	444/5T	254	127	102	G	6.0	582	1.9	2.2	93.6	94.1	94.1	0.63	0.74	0.79	87.3	15	33	1599	63.0
125	90	3570	444/5TS	268	134	107	F	6.5	181	2.0	2.5	93.6	94.5	95.0	0.82	0.87	0.89	33.5	29	64	1599	81.0
125	90	1780	444/5T	278	139	111	G	6.5	364	2.0	2.5	95.0	95.4	95.4	0.74	0.82	0.85	57.2	27	59	1590	73.0
125	90	1185	444/5T	286	143	114	G	6.4	547	2.1	2.4	95.0	95.4	95.0	0.70	0.79	0.83	104	19	42	1751	69.0
125	90	890	504/5T	298	149	119	F	5.8	728	1.8	2.0	94.5	94.5	94.5	0.66	0.76	0.80	104	23	51	2110	66.0
125	90	890	445/7T	302	151	121	G	6.0	728	1.8	2.1	94.5	94.5	94.5	0.64	0.74	0.79	104	17	37	1887	63.0
150	110	3570	444/5TS	322	161	129	F	6.5	218	1.8	2.4	94.1	95.0	95.0	0.83	0.88	0.90	39.1	22	48	1709	81.0
150	110	1780	444/5T	340	170	136	G	6.6	437	2.0	2.5	95.4	95.8	95.8	0.74	0.82	0.85	66.7	27	59	1676	73.0
150	110	1190	504/5T	352	176	141	G	6.7	653	2.3	2.5	94.5	95.4	95.8	0.67	0.78	0.82	134	29	64	2249	70.0
150	110	1190	445/7T	352	176	141	G	6.7	653	2.4	2.9	95.0	95.4	95.8	0.67	0.78	0.82	134	20	44	2042	69.0
150	110	890	504/5T	360	180	144	F	5.8	873	1.8	2.0	94.5	94.5	94.5	0.68	0.77	0.81	125	21	46	2293	66.0
150	110	890	445/7T	370	185	148	G	6.0	873	1.9	2.1	94.5	94.5	94.5	0.64	0.74	0.79	125	15	33	2042	63.0
200	150	3575	447/9TS	444	222	178	H	7.2	290	2.0	2.7	94.1	95.0	95.4	0.81	0.87	0.89	44.7	17	37	2168	81.0
200	150	3575	504/5TS	444	222	178	H	7.2	290	2.0	2.7	94.1	95.0	95.4	0.81	0.87	0.89	44.7	17	37	2168	81.0
200	150	3570	445/7TS	438	219	175	G	7.2	290	2.4	2.4	95.0	95.4	95.4	0.86	0.89	0.90	44.7	14	31	1914	81.0
200	150	1785	504/5T	456	228	182	G	6.6	580	2.2	2.2	95.4	96.2	96.2	0.75	0.83	0.86	76.2	22	48	2273	75.0
200	150	1780	444/5T	460	230	184	G	6.8	582	2.4	2.5	95.4	96.2	96.2	0.73	0.82	0.85	76.2	16	35	1899	73.0
200	150	1780	445/7T	460	230	184	G	6.8	582	2.4	2.5	95.4	96.2	96.2	0.73	0.82	0.85	76.2	16	35	1899	73.0
200	150	1780	447/9T	460	230	184	G	6.8	582	2.4	2.5	95.4	96.2	96.2	0.73	0.82	0.85	76.2	16	35	1899	73.0
200	150	1190	504/5T	474	237	190	G	6.6	871	2.2	2.3	95.0	95.4	95.8	0.70	0.80	0.83	145	21	46	2459	70.0
200	150	1190	447/9T	474	237	190	G	6.6	871	2.3	2.4	95.0	95.4	95.8	0.68	0.79	0.83	145	15	33	2247	69.0
200	150	1190	445/7T	474	237	190	G	6.6	871	2.3	2.4	95.0	95.4	95.8	0.68	0.79	0.83	145	15	33	2247	69.0
200	150	890	447/9T	508	254	203	G	6.2	1164	2.0	2.2	94.5	95.0	95.0	0.62	0.73	0.78	161	13	29	2509	63.0
200	150	895	586/7T	494	247	198	G	6.3	1158	1.4	2.1	95.0	95.4	95.4	0.65	0.75	0.80	350	40	88	3334	75.0
250	185	3575	504/5TS	538	269	215	G	7.0	362	2.0	2.4	95.0	95.8	95.8	0.85	0.89	0.90	50.3	23	51	2388	81.0
250	185	3570	447/9TS	532	266	213	F	6.5	363	2.3	2.2	95.4	95.8	95.8	0.87	0.90	0.91	50.3	18	40	2159	81.0
250	185	3570	445/7TS	532	266	213	F	6.5	363	2.3	2.2	95.4	95.8	95.8	0.87	0.90	0.91	50.3	18	40	2159	81.0
250	185	1785	504/5T	554	277	222	G	6.6	726	2.3	2.2	95.8	96.2	96.2	0.78	0.85	0.87	89.6	20	44	2450	75.0
250	185	1780	445/7T	562	281	225	G	6.6	728	2.3	2.4	95.8	96.2	96.2	0.75	0.83	0.86	89.6	15	33	2079	73.0
250	185	1780	447/9T	562	281	225	G	6.6	728	2.3	2.4	95.8	96.2	96.2	0.75	0.83	0.86	89.6	15	33	2079	73.0
250	185	1185	447/9T	584	292	234	G	6.7	1093	2.4	2.4	95.0	95.4	95.8	0.68	0.79	0.83	145	12	26	2538	69.0
250	185	1190	586/7T	598	299	239	G	6.2	1088	2.0	2.1	95.0	95.4	95.8	0.68	0.77	0.81	226	30	66	3206	77.0
250	185	895	586/7T	598	299	239	G	6.2	1447	1.4	2.1	95.4	95.8	95.8	0.66	0.76	0.81	395	40	88	3649	75.0
250	185	890	L447/9T	616	308	246	G	6.0	1455	2.0	2.3	95.4	95.4	95.4	0.65	0.75	0.79	255	24	53	3550	64.0
300	220	3570	447/9TS	640	320	256	G	7.0	435	2.5	2.4	95.4	95.8	95.8	0.86	0.89	0.90	58.1	14	31	2545	81.0
300	220	3580	586/7TS	634	317	254	F	6.5	434	1.5	2.2	95.0	95.8	95.8	0.87	0.90	0.91	123	35	77	3382	84.0
300	220	1790	586/7T	668	334	267	G	6.8	868	2.3	2.3	95.4	96.2	96.2	0.77	0.84	0.86	161	19	42	3080	78.0
300	220	1780	447/9T	660	330	264	G	6.5	873	2.3	2.3	95.8	96.2	96.2	0.77	0.84	0.87	89.6	16	35	2381	73.0
300	220	1185	447/9T	694	347	278	G	6														

W22 - NEMA Premium Efficiency

Output		Rated speed (rpm)	Frame	Full load current In (A)			Locked Rotor Current		Full Load Torque (ft.lb)	Locked Rotor Torque Tl/Tn	Break-down Torque Tb/Tn	Efficiency			Power Factor			Inertia J (lb.ft ²)	Allowable locked rotor time (s)		Weight (lb)	Sound dB(A)
HP	kW			At 230 V	At 460 V	At 575 V	Code	ll/In				% of full load							Hot	Cold		
												50	75	100	50	75	100					
350	260	3575	447/9TS	754	377	302	H	7.6	507	2.4	2.5	95.4	96.2	96.2	0.85	0.89	0.90	68.1	10	22	2701	81.0
350	260	3580	586/7TS	746	373	298	G	6.6	507	1.6	2.3	95.4	96.2	96.2	0.86	0.90	0.91	136	28	62	3621	84.0
350	260	1790	586/7T	788	394	315	G	6.4	1013	2.0	2.0	95.8	96.2	96.2	0.78	0.85	0.86	179	23	51	2675	78.0
350	260	1780	447/9T	788	394	315	G	6.9	1019	2.5	2.4	95.8	96.2	96.2	0.77	0.84	0.86	118	14	31	2675	73.0
350	260	1190	586/7T	842	421	337	G	6.3	1524	2.1	2.1	95.4	95.8	95.8	0.67	0.77	0.81	328	29	64	3784	77.0
350	260	1190	L447/9T	830	415	332	G	6.4	1524	2.5	2.7	95.4	95.8	95.8	0.66	0.77	0.82	257	23	51	3574	71.0
350	260	895	586/7T*	852	426	341	G	6.4	2026	1.6	2.3	95.4	95.8	95.8	0.64	0.75	0.80	484	34	75	4309	75.0
400	300	3580	586/7TS	860	430	344	F	6.5	579	1.8	2.2	95.8	96.2	96.2	0.88	0.90	0.91	122	48	106	3749	84.0
400	300	3575	L447/9TS	864	432	346	G	6.7	580	2.2	2.5	95.4	95.8	95.8	0.85	0.90	0.91	91.9	25	55	3158	88.0
400	300	1790	586/7T	910	455	364	G	6.4	1158	2.0	2.2	95.8	96.2	96.2	0.78	0.85	0.86	179	19	42	3455	78.0
400	300	1790	L447/9T	910	455	364	H	7.0	1158	2.5	2.6	95.4	95.8	96.2	0.74	0.82	0.86	136	21	46	3285	79.0
400	300	1190	586/7T	966	483	386	G	6.5	1741	2.3	2.1	95.4	95.8	96.2	0.67	0.77	0.81	368	29	64	4115	77.0
400	300	1190	L447/9T*	954	477	382	H	6.9	1741	2.4	2.5	95.4	95.8	95.8	0.68	0.78	0.82	278	13	29	3682	71.0
400	300	895	588/9T	1000	498	398	H	6.7	2315	1.5	2.4	95.0	95.6	95.7	0.62	0.73	0.79	536	25	55	4851	75.0
450	330	3580	586/7TS	946	473	378	F	6.6	651	2.0	2.3	95.8	96.2	96.2	0.88	0.90	0.91	132	34	75	3918	84.0
450	330	3575	L447/9TS	950	475	380	G	7.2	652	2.4	2.6	95.4	95.8	95.8	0.84	0.89	0.91	100	26	57	3268	88.0
450	330	1790	586/7T	1000	501	401	G	6.8	1302	2.4	2.1	95.8	96.2	96.2	0.78	0.85	0.86	213	16	35	3640	78.0
450	330	1790	L447/9T	1000	501	401	G	6.9	1302	2.6	2.5	95.4	96.2	96.2	0.74	0.83	0.86	152	22	48	3396	79.0
450	330	1190	586/7T	1060	532	426	G	6.2	1959	2.1	2.1	95.8	96.2	96.2	0.67	0.77	0.81	368	26	57	4384	77.0
450	330	895	588/9T	1110	554	443	H	7.0	2605	1.6	2.6	95.2	95.7	95.8	0.60	0.72	0.78	616	27	59	5281	75.0
500	370	3580	586/7TS	1060	530	424	G	6.8	724	2.2	2.4	95.8	96.2	96.2	0.88	0.90	0.91	143	39	86	4086	84.0
500	370	1790	586/7T	1110	555	444	G	6.5	1447	2.4	2.0	95.8	96.2	96.2	0.80	0.85	0.87	256	16	35	3912	78.0
500	370	1785	L447/9T*	1120	561	449	H	7.2	1451	2.5	2.6	95.4	96.2	96.2	0.73	0.82	0.86	160	22	48	3462	79.0
500	370	1190	586/7T	1210	603	482	G	6.5	2177	2.2	2.1	95.8	96.2	96.2	0.66	0.76	0.80	368	25	55	4403	77.0
550	400	3585	588/9TS	1160	578	462	G	7.4	795	2.3	2.7	96.0	96.5	96.5	0.84	0.89	0.90	155	33	73	4410	89.0
550	400	1790	586/7T	1210	605	484	G	7.1	1592	2.2	2.5	96.2	96.4	96.5	0.74	0.82	0.86	236	16	35	4335	78.0
550	400	1190	588/9T	1320	661	529	G	6.5	2395	2.2	2.3	95.2	96.0	96.1	0.63	0.74	0.79	389	30	66	4734	77.0
600	450	3585	588/9TS	1300	650	520	H	7.4	867	2.3	2.7	96.0	96.5	96.5	0.84	0.89	0.90	155	33	73	4410	89.0
600	440	1790	586/7T	1330	665	532	G	7.1	1737	2.2	2.5	96.2	96.4	96.5	0.74	0.82	0.86	236	16	35	4335	78.0
600	450	1190	588/9T	1490	743	594	H	6.5	2612	2.2	2.3	95.4	96.1	96.2	0.63	0.74	0.79	449	31	68	5173	77.0
650	480	3585	588/9TS	1370	685	548	G	7.1	939	2.0	2.4	96.1	96.6	96.6	0.86	0.90	0.91	176	56	123	4635	89.0
650	480	1790	588/9T	1470	734	587	H	7.4	1881	2.5	2.7	96.0	96.5	96.6	0.71	0.81	0.85	301	22	48	4395	81.0
700	515.2	3585	588/9TS*	1470	736	589	G	7.2	1012	2.3	2.5	96.2	96.6	96.6	0.86	0.90	0.91	183	34	75	4805	89.0
700	515.2	1790	588/9T	1580	788	630	G	7.0	2026	2.5	2.6	96.2	96.5	96.6	0.71	0.81	0.85	335	23	51	4584	81.0
750	550	1790	588/9T	1680	840	672	G	7.0	2171	2.4	2.5	96.3	96.6	96.7	0.70	0.80	0.85	347	29	64	4952	81.0

Notes:

(*) Fitted with air deflector in the drive end side.

(**) Class "F" insulation ΔT 105 K.



W22 - Super Premium Efficiency

Output		Rated speed (rpm)	Frame	Full load current In (A)			Locked Rotor Current		Full Load Torque (ft.lb)	Locked Rotor Torque Tl/Tn	Break-down Torque Tb/Tn	Efficiency			Power Factor			Inertia J (lb.ft ²)	Allowable locked rotor time (s)		Weight (lb)	Sound dB(A)
HP	kW			At 230 V	At 460 V	At 575 V	Code	l/In				% of full load			50	75	100		50	75		
1	0.75	3485	143T	2.70	1.35	1.08	J	7.2	1.52	2.5	3.0	81.5	82.5	84.0	0.69	0.79	0.83	0.0413	36	80	39.7	68
1	0.75	1760	L143T	2.66	1.33	1.06	K	8.4	3.00	2.6	3.3	84.0	86.5	87.5	0.63	0.74	0.81	0.1561	29	65	50.7	51
1.5	1.1	3485	143T	3.85	1.92	1.54	K	7.8	2.22	3.0	3.5	84.0	85.5	86.5	0.67	0.78	0.83	0.0467	29	64	41.9	68
1.5	1.1	1760	L145T	3.85	1.93	1.54	K	8.4	4.40	2.8	3.4	85.5	87.5	88.5	0.62	0.74	0.81	0.1822	20	44	55.1	51
2	1.5	3490	145T	5.12	2.56	2.05	K	8.2	3.03	3.2	3.6	85.5	87.5	87.5	0.69	0.80	0.84	0.0605	23	51	50.7	68
2	1.5	1760	L145T	5.29	2.64	2.11	K	8.2	6.00	2.9	3.6	86.5	87.5	88.5	0.61	0.74	0.81	0.1822	14	30	57.3	51
3	2.2	3520	182T	7.34	3.67	2.94	K	8.2	4.40	2.4	3.6	84.0	86.5	88.5	0.70	0.81	0.85	0.1889	50	110	88.2	69
3	2.2	1765	L182T	7.53	3.76	3.01	J	7.7	8.78	2.3	3.2	87.5	88.5	91.0	0.63	0.75	0.81	0.4018	36	80	92.6	56
3	2.2	1175	L213T	8.60	4.30	3.44	J	6.6	13.2	1.8	2.9	87.5	89.5	90.2	0.51	0.63	0.71	1.53	90	198	172	55
5	3.7	3505	184T	12.0	5.99	4.79	J	8.2	7.44	2.4	3.5	87.5	88.5	90.2	0.73	0.83	0.86	0.2233	30	65	94.8	69
5	3.7	1755	L184T	12.8	6.40	5.12	J	7.5	14.8	2.3	3.1	88.5	90.2	91.0	0.61	0.73	0.80	0.4893	24	54	101	56
5	3.7	1170	L215T	13.7	6.83	5.46	J	6.5	22.3	1.9	2.5	89.5	91.0	91.0	0.56	0.68	0.75	1.80	70	154	198	55
7.5	5.5	3530	213T	17.6	8.82	7.06	J	7.6	11.0	2.3	3.3	87.5	89.5	91.0	0.73	0.82	0.86	0.5513	37	81	141	72
7.5	5.5	1770	L213T	17.9	8.94	7.15	K	8.5	21.9	2.3	3.5	91.0	92.4	93.0	0.65	0.76	0.83	1.52	20	44	172	58
7.5	5.5	1175	254T	18.9	9.46	7.57	H	6.8	33.0	2.5	3.1	90.2	91.7	92.4	0.60	0.72	0.79	4.57	50	110	304	59
10	7.5	3535	215T	23.0	11.5	9.22	H	7.6	14.9	2.4	3.2	89.5	91.0	91.7	0.77	0.85	0.89	0.7209	34	75	172	72
10	7.5	1765	L215T	24.1	12.0	9.64	J	8.4	29.9	2.3	3.5	91.7	92.4	93.0	0.66	0.78	0.84	1.78	16	35	181	58
10	7.5	1180	256T	25.5	12.7	10.2	H	6.8	44.8	2.4	3.0	91.0	92.4	92.4	0.62	0.74	0.80	5.40	40	87	344	59
15	11	3545	254T	34.7	17.4	13.9	J	7.7	21.9	2.7	3.5	90.2	91.7	92.4	0.72	0.82	0.86	1.56	28	61	273	72
15	11	1775	254T	35.5	17.8	14.2	J	7.8	43.6	2.8	3.3	91.7	93.0	93.6	0.66	0.76	0.83	3.64	20	44	280	64
15	11	1180	284T	36.2	18.1	14.5	H	7.1	65.7	2.6	3.0	91.7	92.4	93.0	0.65	0.76	0.82	7.69	28	63	410	59
20	15	3545	256T	46.0	23.0	18.4	H	7.6	29.8	2.6	3.4	91.0	92.4	93.0	0.75	0.84	0.88	1.91	23	51	311	72
20	15	1770	256T	48.8	24.4	19.5	J	7.3	59.7	2.6	3.0	93.0	93.6	94.1	0.64	0.76	0.82	4.30	30	66	326	64
20	15	1180	286T	48.8	24.4	19.5	J	7.4	89.5	2.7	3.0	91.7	92.4	93.0	0.67	0.78	0.83	8.65	20	44	474	59
25	18.5	3550	284TS	57.0	28.5	22.8	H	7.5	36.7	2.4	3.3	91.7	93.0	93.6	0.75	0.83	0.87	2.68	20	44	386	72
25	18.5	1775	284T	60.7	30.3	24.3	J	7.5	73.4	3.0	3.4	93.0	94.1	94.5	0.62	0.74	0.81	4.95	26	57	406	64
25	18.5	1185	324T	61.7	30.8	24.7	J	7.3	110	2.6	3.1	92.4	93.6	94.1	0.61	0.73	0.80	11.2	30	66	527	62
30	22	3550	286TS	67.0	33.5	26.8	H	7.5	43.6	2.4	3.3	92.4	93.6	93.6	0.76	0.84	0.88	3.19	19	41	437	72
30	22	1775	286T	71.3	35.6	28.5	J	7.4	87.3	2.9	3.2	93.0	94.1	94.5	0.64	0.76	0.82	5.67	25	54	450	64
30	22	1185	326T	73.4	36.7	29.3	H	7.0	131	2.6	3.0	92.4	93.6	94.1	0.60	0.73	0.80	12.9	27	59	584	62
40	30	3565	324TS	93.1	46.5	37.2	H	7.5	59.3	2.8	3.0	92.4	94.1	94.1	0.74	0.83	0.86	4.63	27	60	547	75
40	30	1780	324T	97.9	48.9	39.1	J	7.4	119	2.6	3.0	93.6	94.5	95.0	0.64	0.75	0.81	8.83	22	48	534	65
40	30	1185	364/5T	97.9	48.9	39.1	K	8.4	178	2.6	3.2	93.6	94.5	95.0	0.64	0.76	0.81	24.2	22	48	875	64
50	37	3570	326TS	114	57.1	45.7	J	7.7	73.0	3.0	3.0	93.0	94.5	94.5	0.74	0.83	0.86	5.43	25	55	606	75
50	37	1780	326T	120	60.1	48.1	J	7.4	146	2.6	3.0	94.1	95.0	95.4	0.62	0.73	0.81	9.41	20	45	597	65
50	37	1185	364/5T	121	60.3	48.3	K	8.5	220	2.6	3.3	93.6	94.5	95.0	0.63	0.75	0.81	25.0	16	36	895	64
60	45	3570	364/5TS	134	66.8	53.4	H	7.9	88.8	2.4	3.2	93.0	94.5	95.0	0.79	0.86	0.89	8.61	25	56	926	78
60	45	1780	364/5T	140	70.2	56.1	H	7.6	178	2.7	3.2	94.5	95.4	95.8	0.69	0.80	0.84	16.9	24	53	897	70
60	45	1185	404/5T	144	72.2	57.8	J	7.9	267	2.8	3.2	94.1	95.0	95.4	0.65	0.77	0.82	39.1	25	56	1111	64
75	55	3570	364/5TS	165	82.6	66.1	J	8.0	109	2.6	3.2	93.6	95.0	95.0	0.77	0.85	0.88	8.61	18	39	937	78
75	55	1780	364/5T	174	86.8	69.5	J	7.7	218	2.8	3.2	94.5	95.4	95.8	0.68	0.78	0.83	17.4	16	35	919	70
75	55	1190	404/5T	179	89.3	71.5	J	8.0	326	2.8	3.0	94.1	95.0	95.4	0.64	0.75	0.81	41.2	20	44	1124	64
100	75	3570	404/5TS	219	110	87.7	H	8.0	148	2.7	3.2	94.5	95.4	95.4	0.81	0.88	0.90	14.3	20	43	1179	78
100	75	1780	404/5T	233	116	93.2	J	8.2	297	2.7	3.1	95.4	95.8	96.2	0.70	0.80	0.84	28.6	12	26	1188	70
100	75	1190	444/5T	249	124	99.5	J	7.6	444	2.6	3.2	94.5	95.4	95.8	0.60	0.72	0.79	106	27	60	1896	69
125	93	3580	444/5TS	280	140	112	H	7.6	183	2.3	3.1	94.1	95.4	95.8	0.76	0.84	0.87	31.3	44	98	1680	79
125	93	1785	444/5T	289	144	116	H	7.2	367	2.2	2.8	95.0	95.8	96.2	0.68	0.79	0.84	58.3	38	84	1722	72
125	93	1190	444/5T	305	152	122	H	7.2	550	2.4	2.6	95.0	95.8	95.8	0.62	0.74	0.80	114	25	55	1944	69
150	110	3580	444/5TS	326	163	130	H	7.9	216	2.6	3.2	94.5	95.8	96.2	0.77	0.85	0.88	38.5	30	66	1863	79
150	110	1785	444/5T	341	170	136	J	7.9	434	2.5	3.0	95.4	96.2	96.5	0.68	0.79	0.84	77.9	38	84	1951	72
150	110	1190	447/9T	359	179	144	J	7.5	651	2.6	3.2	95.0	95.8	96.2	0.62	0.74	0.80	146	22	48	2255	69
200	150	3575	445/7TS	435	217	174	H	7.6	296	2.4	2.9	95.4	96.2	96.2	0.83	0.88	0.90	42.2	28	63	2028	81
200	150	1785	447/9T	469	234	187	J	7.7	592	2.8	3.0	95.8	96.5	96.8	0.66	0.77	0.83	97.6	24	52	2293	75
200	150	1190	447/9T	489	245	196	J	7.5	888	2.6	3.0	95.4	95.8	96.2	0.60	0.72	0.80	150	16	35	2326	69
250	185	3575	445/7TS	535	267	214	H	7.9	364	2.2	3.0	95.8	96.5	96.5	0.82	0.88	0.90	47.2	23	51	2183	81
250	185	1785	447/9T	571	286	228	H	7.5	730	2.7	2.9	96.2	96.5	96.8	0.68	0.78	0.84	108	24	53	2535	75

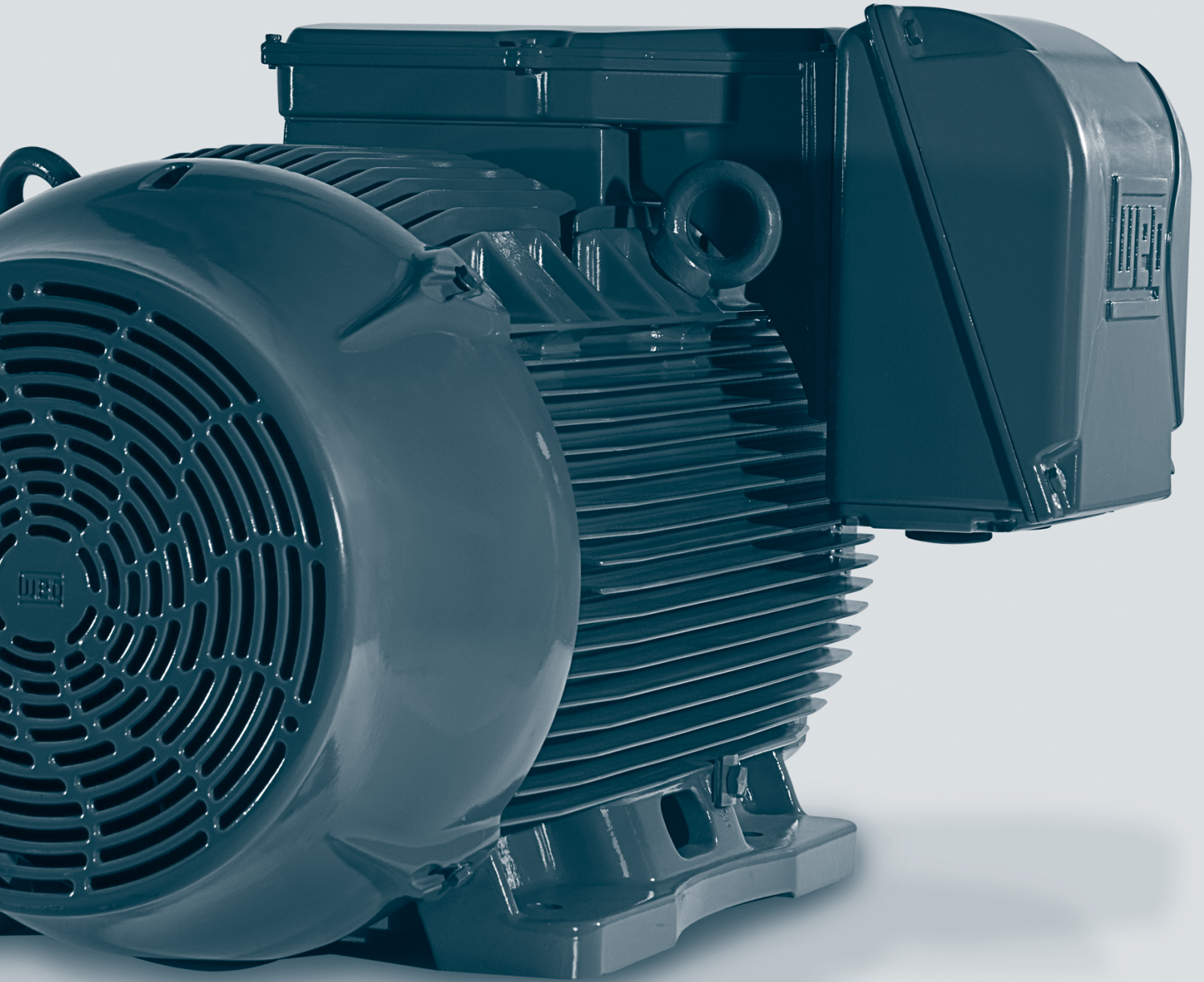

15. Mechanical data

Frames 143T to 215T

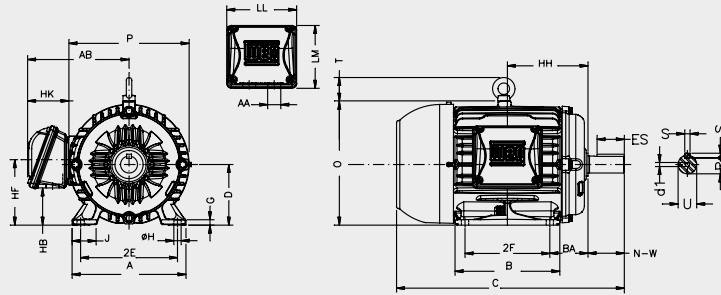

Frames 254T to 326T

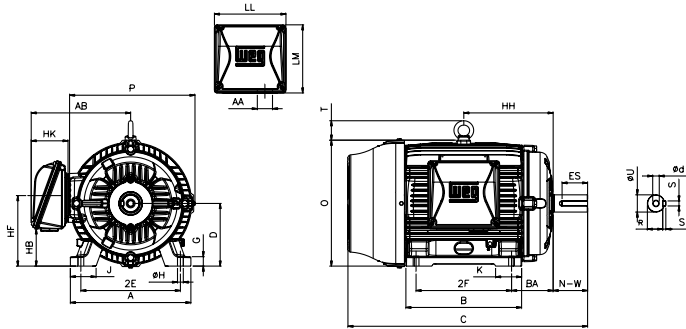

Frames 364 to 444/5T

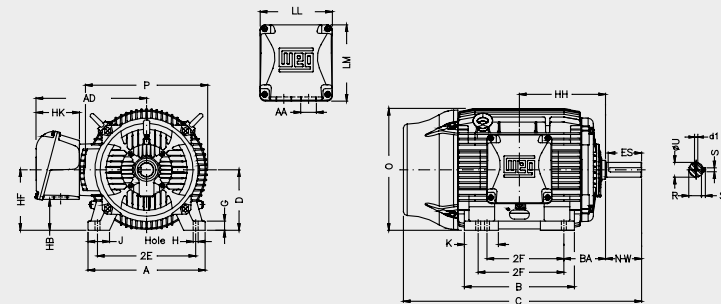

Frames 445/7T to 586/7T

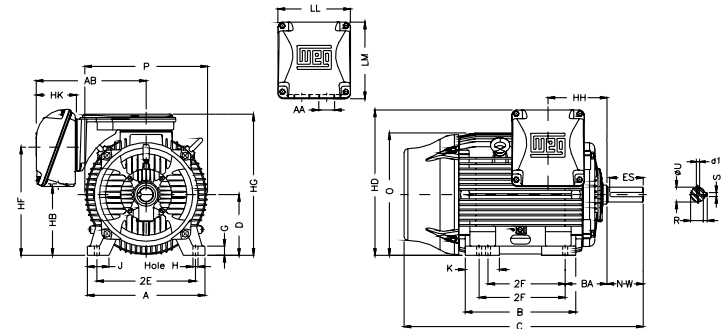

Frame 588/9T

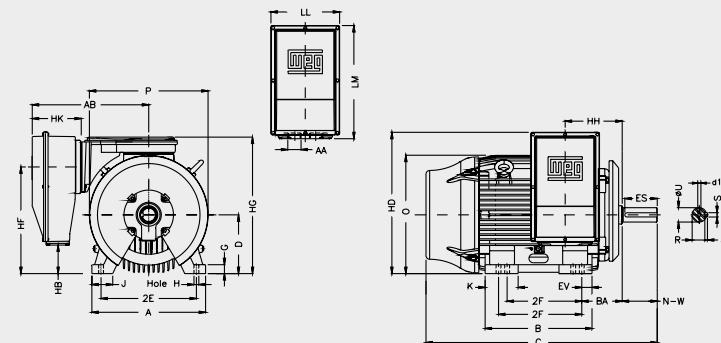

Frame	Mounting				A	B	C	D	G	J	O	K	P	T	Keyway			Shaft Extension	
	2E	2F	H	BA											S	R	ES	N-W	U
143T	5.500	4.000	0.344	2.250	6.457	5.157	12.346	3.500	0.354	1.437	7.122	7.047	-	0.187	0.765	1.575	2.250	0.875	
L143T		5.000				13.566													
L145T						13.346													
L145T	7.500	4.500	0.406	2.750	8.661	6.142	14.566	4.500	0.394	1.594	9.343	-	8.740	1.772	0.250	0.984	1.969	2.750	1.125
L182T						14.860													
L184T						16.041													
L184T	8.500	5.500	0.406	3.500	9.764	6.969	15.860	5.250	0.827	1.988	10.841	10.669	1.772	0.313	1.203	2.480	3.375	1.375	
L213T						17.041													
L215T						18.021													
L215T	10.000	8.252	0.531	4.250	12.126	7.362	19.527	6.250	2.539	12.598	2.559	12.953	2.087	0.375	1.406	2.756	4.000	1.625	
L254T						20.905													
L256T						21.732													
L256T	11.000	9.500	0.531	4.750	13.780	8.858	25.061	7.000	1.023	3.110	14.067	2.874	14.173	2.087	0.375	1.406	2.480	3.250	1.625
L284TS						26.557													
L284T						27.929													
L286TS	12.500	10.500	0.657	5.250	15.157	13.071	28.120	8.000	1.300	3.189	15.953	3.189	15.827	2.441	0.500	1.594	3.149	4.622	1.875
L286T						29.616													
L324TS						31.116													
L324T	14.016	11.260/12.244	0.660	5.875	17.165	14.567	32.276	9.000	1.480	3.150	17.957	4.921	17.914	2.441	0.625	2.019	4.330	5.874	2.375
L326TS						34.251													
L326T						34.251													
L364/5TS	15.984	12.244/13.740	0.810	6.625	19.921	18.386	36.732	10.000	1.811	19.566	5.669	19.134	23.583	-	0.500	1.844	3.937	5.250	2.125
L404/5TS						37.730													
L404/5T						41.200													
L444/5TS	18.000	14.500/16.500	0.810	7.500	21.929	20.315	44.951	11.000	1.654	22.795	5.866	23.583	-	0.625	2.021	3.000	4.750	2.375	
L444/5T						48.701													
L445/7TS						52.588													
L445/7T	20.000/25.000	0.810	7.500	21.929	23.897	31.535	56.338	11.000	1.630	3.937	23.874	8.780	25.866	-	0.625	2.021	3.000	4.750	2.375
L447/9TS						53.431													
L447/9T						57.181													
L447/9T	20.000/25.000	0.810	7.500	21.929	23.897	31.535	58.215	12.500	2.146	4.724	25.425	7.228	25.866	-	0.625	2.021	3.000	4.750	2.375
L504/5TS						54.095													
L504/5T						55.027													
L504/5T	20.000	16.000/18.000	1.250	8.500	24.724	24.449	61.902	12.500	2.146	4.724	25.425	7.228	25.866	-	0.625	2.021	3.000	4.750	2.375
L586/7TS						62.506													
L586/7T						69.381													
L588/9TS	23.000	22.000/25.000	1.181	10.000	29.528	29.921	62.506	14.500	2.492	5.512	28.985	13.030	28.977	-	1.000	3.312	8.661	11.625	3.875
L588/9T						37.980													
L588/9T						69.381													

Frame	Terminal Box										d1	Bearings	
	AB	HB	HD	HF	HG	HH	HK	LL	LM	AA		D.E.	N.D.E.
143T	6.181	1.728		3.500		4.250	2.638	4.527	4.094	NPT3/4"	A 4	6205 ZZ	6204 ZZ
L143T						4.750							
L145T						5.000							
L145T	7.559	2.236		4.500		5.500	3.110	5.512	5.236	NPT1"	A 4	6207 ZZ	6206 ZZ
L182T						6.250							
L184T						7.000							
L184T	8.583	3.006		5.250		7.000	3.110	5.512	5.236	NPT1"	A 4	6308 ZZ	6207 ZZ
L213T						8.376							
L215T						9.250							
L215T	10.394	3.061		6.565		9.500	3.937	7.795	7.402	NPT1 1/2"	A 4	6309 C3	6209 C3
L254T						10.250							
L256T						10.500							
L284TS	10.984	3.535		7.000		11.250	4.645	8.976	8.543	NPT 2"	A 4	6311 C3	6211 C3
L284T						12.362							
L286TS						14.213							
L286T	12.480	4.811		8.708		15.748	5.787	11.811	11.890	NPT 3"	A 4	6312 C3	6212 C3
L324TS						17.041							
L324T						17.041							
L326TS	16.378	4.055				18.021	6.378	9.646	10.119	NPT 3"	UNC 3/4"-10	6314 C3	6314 C3
L326T						19.527							
L364/5TS						20.905							
L364/5T	18.386	5.394				21.732	5.787	11.811	11.890	2xNPT 3"	UNC 3/4"-10	6314 C3	6314 C3
L404/5TS						23.897							
L404/5T						24.449							
L444/5TS	20.670	15.078	27.401	25.889	27.007	11.803	6.968	14.646	15.040	2xNPT 3"	UNC 3/4"-10	6314 C3	6314 C3
L444/5T						13.071							
L445/7TS						15.827							
L445/7T	23.071	15.078	27.401	25.889	27.007	11.500	8.464	15.906	17.244	2xNPT 3"	UNC 3/4"-10	6314 C3	6314 C3
L447/9TS						18.021							
L447/9T						19.527							
L447/9T	20.670	15.275	30.305	24.291	29.409	10.394	6.968	14.646	15.040	2xNPT 3"	UNC 3/4"-10	6314 C3	6314 C3
L504/5TS						13.071							
L504/5T						15.827							
L586/7TS	23.977	18.149	35.354	27.559	30.801	13.386	8.464	15.906	17.244	2xNPT 3"	UNC 3/4"-10	6314 C3	6314 C3
L586/7T						12.362							
L588/9TS						14.213							
L588/9T	27.600	6.063	35.346	26.182	33.346	12.519 (side mounted)/	13.977 (top mounted)	17.441	28.740	2xNPT 3"	UNC 7/8"-9	6322 C3	6319 C3
L588/9T						13.071							

Note:
182T and 184T motors are not available in F-3 mounting.

Flange mounted motors

“D” Flange

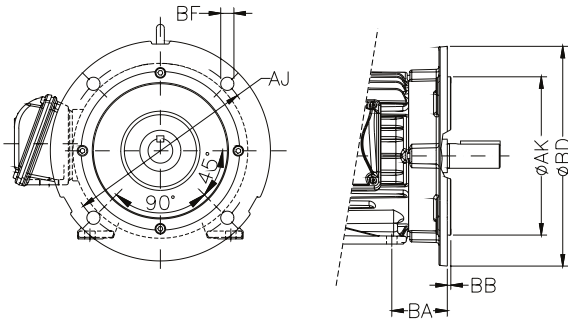

“D” flange dimensions								
Frame	BA	AJ	AK	BD	BF		BB	
					Quantity	Tap size		
143TD / L143TD	2.250	10.000	9.000	11.000	4	0.562	0.203	
145TD / L145TD								
182TD / L182TD								
184TD / L184TD	2.750	10.000	9.000	11.000	4	0.562		
213TD / L213TD								
215TD / L215TD	3.500							
254TD	4.250	12.500	11.000	14.000	4	0.828		
256TD								
284TD								
284TSD	4.750	12.500	11.000	14.000	4	0.828		
286TD								
286TSD								
324TD	5.250	16.000	14.000	18.000	4	0.828		
324TSD								
326TD								
326TSD	5.875	16.000	14.000	17.716	4	0.828		
364/5TD								
364/5TSD	6.625	20.000	18.000	21.653	8	0.828		
404/5TD								
404/5TSD								
444/5TD	7.500	20.000	18.000	21.653	8	0.828		
444/5TSD								
445/7TD								
445/7TSD	8.500	22.000	18.000	24.803	8	0.250		
447/9TD								
447/9TSD								
504/5TD	10.000	30.000	28.000	32.000	8	0.250		
504/5TSD								
586/7TD								
586/7TSD	10.000	30.000	28.000	32.000	8	0.250		
588/9TD								
588/9TSD								

“C” Flange

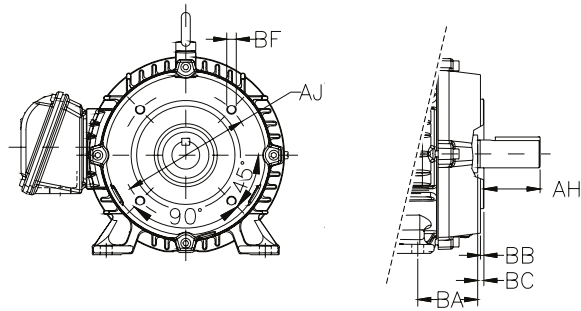

“C” flange dimensions									
Frame	BA	AJ	AK	BD	BF		BB	BC	AH
					Quantity	Tap size			
143TC / L143TC	2.250	5.875	4.500	6.500	4	UNC 3/8"x16	0.156	0.125	2.125
145TC / L145TC									2.625
182TC / L182TC									3.125
184TC / L184TC	2.750	7.250	8.500	8.875	4	UNC 1/2"x13	0.250	0.250	3.125
213TC / L213TC									3.75
215TC / L215TC	3.500								4.375
254TC	4.250	9.000	10.500	11.031	4	UNC 1/2"x13	0.250	0.250	3.000
256TC									4.375
284TC									3.000
284TSC	4.750	9.000	10.500	11.031	4	UNC 1/2"x13	0.250	0.250	4.375
286TC									3.000
286TSC									5.000
324TC	5.250	11.000	12.500	13.583	4	UNC 1/2"x13	0.250	0.250	3.500
324TSC									5.000
326TC									3.500
326TSC	5.875	11.000	12.500	15.551	4	UNC 1/2"x13	0.250	0.250	5.625
364/5TC									3.500
364/5TSC	6.625	14.000	16.000	17.913	8	UNC 5/8"x11	0.250	0.250	7.000
404/5TC									4.000
404/5TSC									8.250
444/5TC	7.500	14.000	16.000	17.913	8	UNC 5/8"x11	0.250	0.250	4.500
444/5TSC									8.250
445/7TC									4.500
445/7TSC	8.500	14.500	16.500	17.913	8	UNC 5/8"x11	0.250	0.250	8.250
447/9TC									4.500
447/9TSC									8.250
L447/9TC	10.000	14.500	16.500	17.913	8	UNC 5/8"x11	0.250	0.250	4.500
L447/9TSC									10.375
504/5TC									4.500
504/5TSC	10.000	14.500	16.500	17.913	8	UNC 5/8"x11	0.250	0.250	11.375
586/7TC									4.500
586/7TSC									11.375
588/9TC	10.000	14.500	16.500	17.913	8	UNC 5/8"x11	0.250	0.250	4.500
588/9TSC									11.375

16. Terminal box drawings

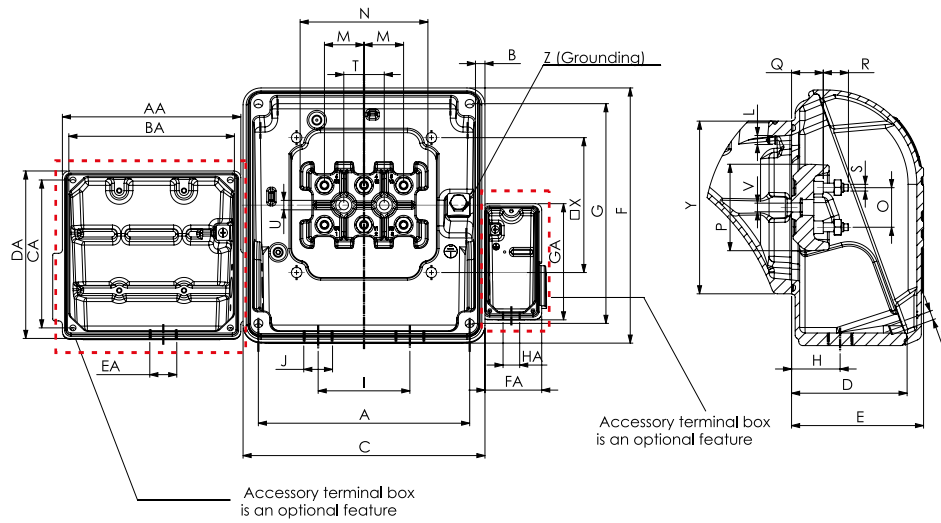

Frames	A	B	C	D	E	F	G	H	I	J	K	L	M	N	O	P	Q	R	S	T	U
143/5T	3.858	0.118	4.508	2.343	2.638	3.976	3.583	1.220	1.654	NPT 3/4"	M5	M5	0.630	2.953	0.630	1.378	0.531	0.472	M4	0.787	0.228
182/4T	4.606	0.098	5.433	2.795	3.150	5.138	4.606	1.437	2.126	NPT 1"	M6	M6	0.906	2.165	0.906	2.047	0.669	0.630	M5	0.906	0.256
213/5T																					
254/6T	6.890	0.157	7.795	3.543	3.957	7.382	6.890	1.929	3.307	NPT 1.1/2"	M8	M8	1.102	3.543	1.102	2.362	0.846	0.807	M6	1.102	0.260
284/6T																					
324/6T	8.031	0.177	8.976	4.213	4.646	8.504	8.031	2.323	3.701	NPT 2"	M8	M8	1.378	4.409	1.378	2.913	0.945	0.945	M8	1.378	0.374
364/5T	9.252	0.492	10.591	5.236	6.024	11.850	10.236	2.795	4.331	NPT 3"	M10	M10	1.732	5.512	1.732	3.701	1.102	1.102	M10		
404/5T	10.827	0.531	12.362			12.244	10.827		4.961												
444/5T																					
445/7T																					
447/9T	13.386		14.921	6.378	7.165	15.354	13.583	3.071	6.299		M12	M12	1.772	6.024	1.772	4.252	1.339	1.575	M12	1.772	
504/5T		0.571																			0.413
L447/9T	14.370		15.906	7.953	8.898	16.614	15.354	3.819	7.874			M14	2.559	8.268	2.559	5.748	1.890	1.890	M16	2.559	
586/7T																					
588/9T	16.339	-	17.402	10.512	13.898	28.701	26.693	7.362	5.512		M10	M12	3.150	-	4.134	-	-	-	M20	-	-

Frames	V	X	Y	Z	AA	BA	CA	DA	EA	FA	GA	HA	MAX CONNECTOR NUMBER			Volume (in ³)															
													MAIN	ACCESSORIES	SPACE HEATER																
143/5T	M5	2.205	3.031	0.5-6mm ²	4.291	3.543	3.346	3.858					4	16		25															
182/4T		2.756	4.213	2-10mm ²									6			49															
213/5T		4.055																													
254/6T	M6	4.331	5.512	5.2-25mm ²	5.472	4.606	4.606	5.236					12			130															
284/6T																															
324/6T	M8	4.724	6.102	5.2-35mm ²										26	4		208														
364/5T		7.559	25-50mm ²																										488		
404/5T		7.756																													
444/5T	M10	8.031	10.236	35-70mm ²	7.795	6.890	6.890	7.441		2.677	5.157	NPT 3/4						1165													
445/7T		7.874																													
447/9T		10.236	11.811	85-120mm ²																											
504/5T																															
L447/9T																															
586/7T																															
588/9T	-	11.417		50-70mm ²																	3200										

Note:
Terminal block is optional on NEMA motors.

17. Drip cover data

Utilization of a rain drip cover increases the total length of the motor. The additional land length can be seen in the table ahead.

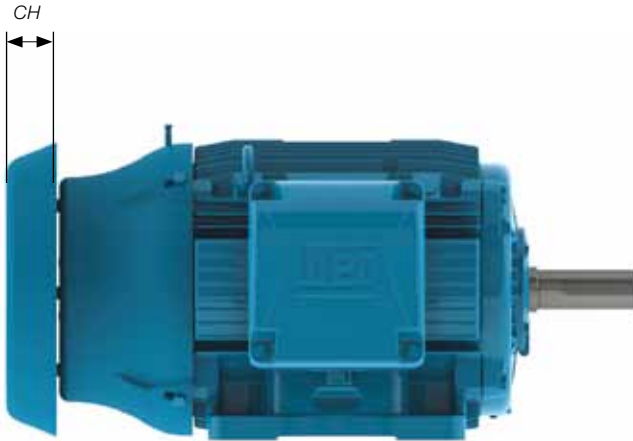

Figure 29 – Motor with drip cover

Frame	Dimension CH [increase motor length (inches)]
143/5T	0.709
182/4T 213/5T	1.220
254/6T	1.850
284/6T	2.244
324/6T	2.638
364/5T 404/5T	3.189
444/5T 445/7T 447/9T	3.583
504/5T	
586/7T	
588/9T	

18. Distance from fan cover to wall

See in the table ahead the distance from fan cover to wall.

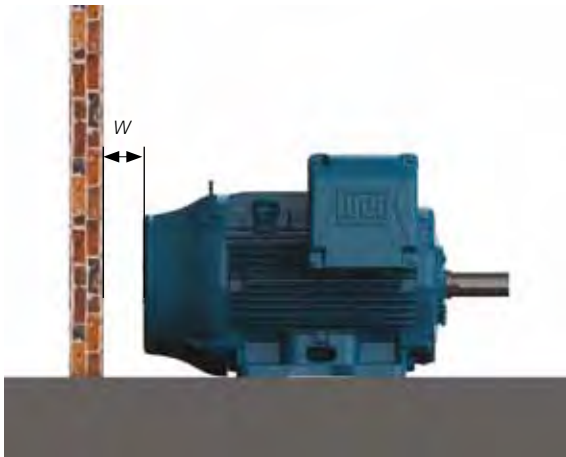

Figure 30: Distance from fan cover to wall

Frame	W - Distance from fan cover to wall [in]
143/5	1.30
182/4	1.61
213/5	1.98
254/6	2.56
284/6	2.66
324/6	3.08
364/5 404/5	3.35
444/5 445/7 447/9	4.23
L447/9 504/5	4.80
586/7 588/9	5.35

19. Packaging

W22 motors in frames 143T to 215T are packaged in cardboard boxes (see figure 31), following the dimensions, weights and volumes opposite:



Figure 31: Cardboard box

Top mounted terminal box

Frame	External height (in)	External width (in)	External length (in)	Weight (lbf)	Volume (ft ³)
143T	12.598	10.630	17.008	2.0	1.3
145T	12.598	10.630	17.008	2.0	1.3
213T	16.535	12.992	23.425	3.7	2.9
215T	16.535	12.992	23.425	3.7	2.9

*F-3 mounting not available for frames 182 and 184

Side mounted terminal box

Frame	External height (in)	External width (in)	External length (in)	Weight (lbf)	Volume (ft ³)
143T	9.252	12.402	15.669	1.8	1.0
145T	9.252	12.402	15.669	1.8	1.0
182T	11.811	14.961	18.307	2.6	1.9
184T	11.811	14.961	18.307	2.6	1.9
213T	13.780	16.535	23.425	4.5	3.1
215T	13.780	16.535	23.425	4.5	3.1

Top mounted terminal box

Frame	External height (in)	External width (in)	External length (in)	Weight (lbf)	Volume (ft ³)
254T	19.764	15.827	29.134	20.2	5.3
256T	19.764	15.827	29.134	20.2	5.3
284T	20.945	17.008	32.283	27.0	6.7
286T	20.945	17.008	32.283	27.0	6.7
324T	23.307	20.157	34.646	29.7	9.4
326T	23.307	20.157	34.646	29.7	9.4
364/5T	35.433	33.465	45.276	114.4	31.1
404/5T	35.433	33.465	49.213	120.3	33.8
444/5T	44.488	33.465	55.118	149.7	47.5
445/7T	44.488	33.465	62.992	177.7	54.3
447/9T	44.488	33.465	66.929	182.3	57.7
L447/9T	44.488	33.465	66.929	182.3	57.7
504/5T	44.488	33.465	61.024	154.1	52.6
586/7T	52.874	41.339	71.654	284.4	90.6
588/9T	56.063	50.787	80.709	427.7	133.0

For frames 254T to 588/9T, the motors are packaged in wooden crates (see figure 32). Dimensions, weights and volumes are in tables opposite.



Figure 32: Wooden crates

Side mounted terminal box

Frame	External height (in)	External width (in)	External length (in)	Weight (lbf)	Volume (ft ³)
254T	15.827	20.157	29.134	21.7	5.4
256T	15.827	20.157	29.134	21.7	5.4
284T	17.795	22.520	32.283	29.6	7.5
286T	17.795	22.520	32.283	29.6	7.5
324T	19.370	24.882	34.646	32.1	9.7
326T	19.370	24.882	34.646	32.1	9.7
364/5T	31.496	33.465	45.276	109.6	27.6
404/5T	35.433	33.465	49.213	115.1	33.8
444/5T	37.402	37.402	55.118	157.9	44.6
445/7T	37.402	43.307	62.992	172.8	59.0
447/9T	37.402	43.307	66.929	188.1	62.7
L447/9T	37.402	43.307	66.929	188.1	62.7
504/5T	44.488	43.307	62.992	204.8	70.2
586/7T	44.488	46.850	71.654	324.1	86.4
588/9T	46.220	50.866	80.709	403.4	109.8

Note: Values to be added to the net motor weight

20. Spare parts

General Information

The following information is required when purchasing of spare parts:

- Serial number and manufacturing date, both stamped in the nameplate
- Spare part description
- Codes shown are for reference only. Final codes of spare parts will depend on colour

Spare Parts Available 143T to 184T

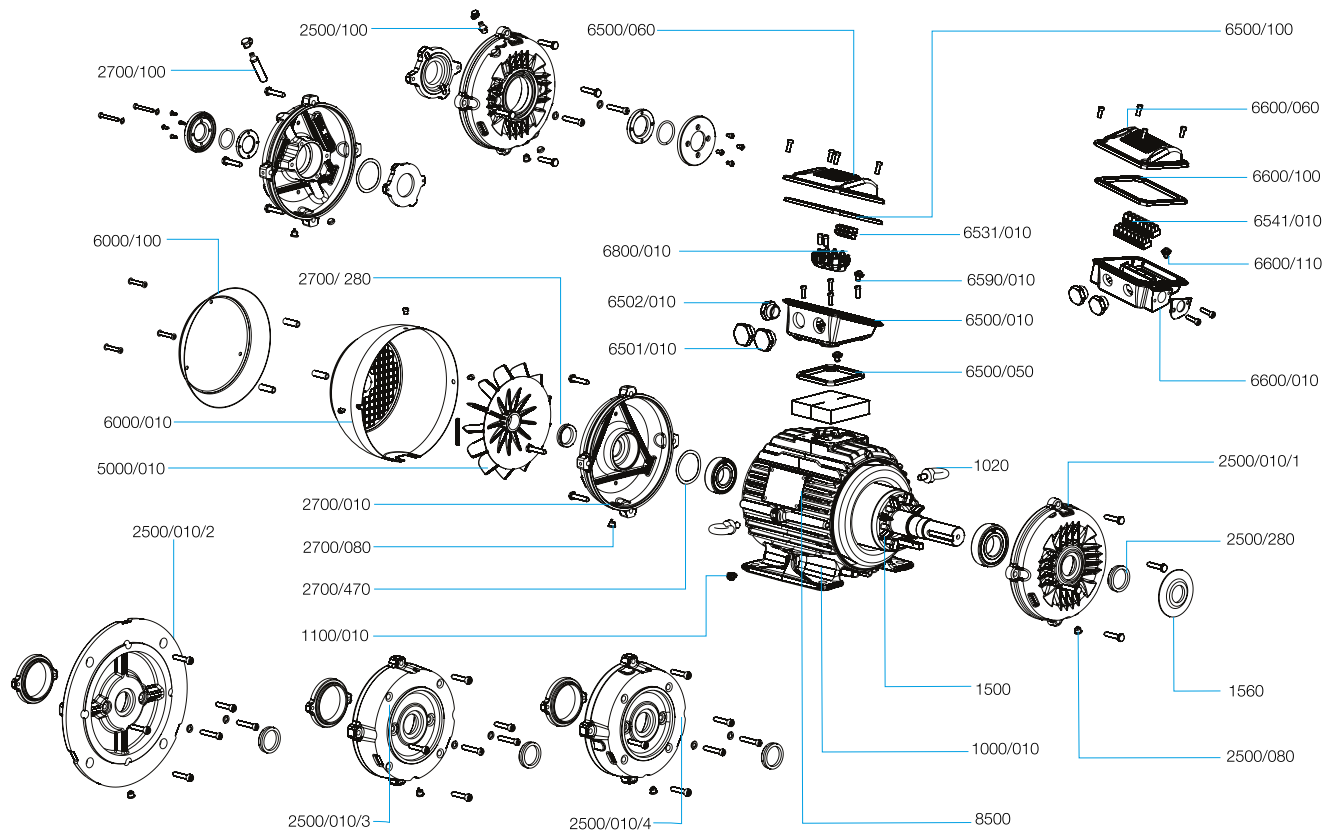

Note: Conduit box location is shown as F-3, actual location will be based on serial number.

Motor component		Spare part	
Item	Description	Item	Composition
1000/010	Frame with wound stator		
1020	Lifting eyebolt	1020	Lifting eyebolt
1100/010	Earthing terminal		
1500	Rotor, complete with shaft and key		
1560	Slinger	1560	Slinger (recommended for vertical shaft up applications, non-flange mounted)
2500/010/1	Endshield, drive end	2500/1	Endshield, drain plug, shaft seal, bolts and washers
2500/080	Drain plug, drive end		
2500/100	Grease nipple, drive end (2)		
2500/280	Shaft seal, drive end (1)		
2500/010/2	D Flange	2500/2	D Flange, drain plug, shaft seal, bolts and washers
2500/080	Drain plug, drive end		
2500/100	Grease nipple, drive end (2)		
2500/280	Shaft seal, drive end (1)		
2500/010/3	C Flange (5)	2500/3	C Flange, drain plug, shaft seal, bolts and washers
2500/080	Drain plug, drive end		
2500/100	Grease nipple, drive end (2)		
2500/280	Shaft seal, drive end (1)		
2700/010	Endshield, non-drive end	2700	Endshield, drain plug, shaft seal, bolts and washers
2700/080	Drain plug, non-drive end		
2700/100	Grease nipple, non-drive end (2)		
2700/280	Shaft seal, non-drive end (1)		
2700/470	Wave washer for axial displacement		
5000/010	Fan	5000	Fan (3)
6000/010	Fan cover (4)	6000	Fan cover, bolts
		6050	Fan cover, drip cover and bolts
6000/100	Drip cover	6100	Drip cover, bolts
6500/010	Terminal box	6500	Terminal box complete with lid, gaskets (for lid and terminal box), plugs (for mains and accessories), earthing terminal, bolts and washers
6500/050	Terminal box gasket		
6500/060	Terminal box lid		
6500/100	Terminal box lid gasket		
6501/010	Terminal box plug for main leads		
6502/010	Terminal box plug for accessory leads		
6590/010	Terminal box earthing terminal		
6531/010	Accessory connector	6531	Accessory connector, mounting rail, bolts and washers
6541/010	Accessory connector	6541	Accessory connector, mounting rail, bolts and washers
6600/010	Accessory terminal box	6600	Accessory terminal box, complete with lid, gasket, plugs, earthing terminal, bolts and washers
6600/060	Accessory terminal box lid		
6600/100	Accessory terminal box lid gasket		
6600/110	Accessory terminal box earthing terminal		
6800/010	Terminal block	6800	Terminal block, bolts and washers
8500	Main nameplate		

Notes:

- (1) The shaft sealing may vary with product line. As a spare part, the shaft sealing in the 143/5T - 182/4T range will be supplied as an integral part of the endshield kit.
- (2) When fitted with grease nipple, the endshield spare part kit will also have grease relief, internal bearing cap and labyrinth seal (taconite or W3 Seal®).
- (3) When non-plastic fan is fitted, the spare part kit is also supplied with key and circlip for fan assembly onto the shaft.
- (4) The fan cover material may vary with product line. Considering general purpose, it is steel fabricated in the 143/5T - 182/4T frame.
- (5) C flange dimensions according to NEMA MG-1 Part 4.

General Information

The following information is required when purchasing of spare parts:

- Serial number and manufacturing date, both stamped in the nameplate
- Spare part description
- Codes shown are for reference only. Final codes of spare parts will depend on colour

Spare Parts Available 213T to 326T

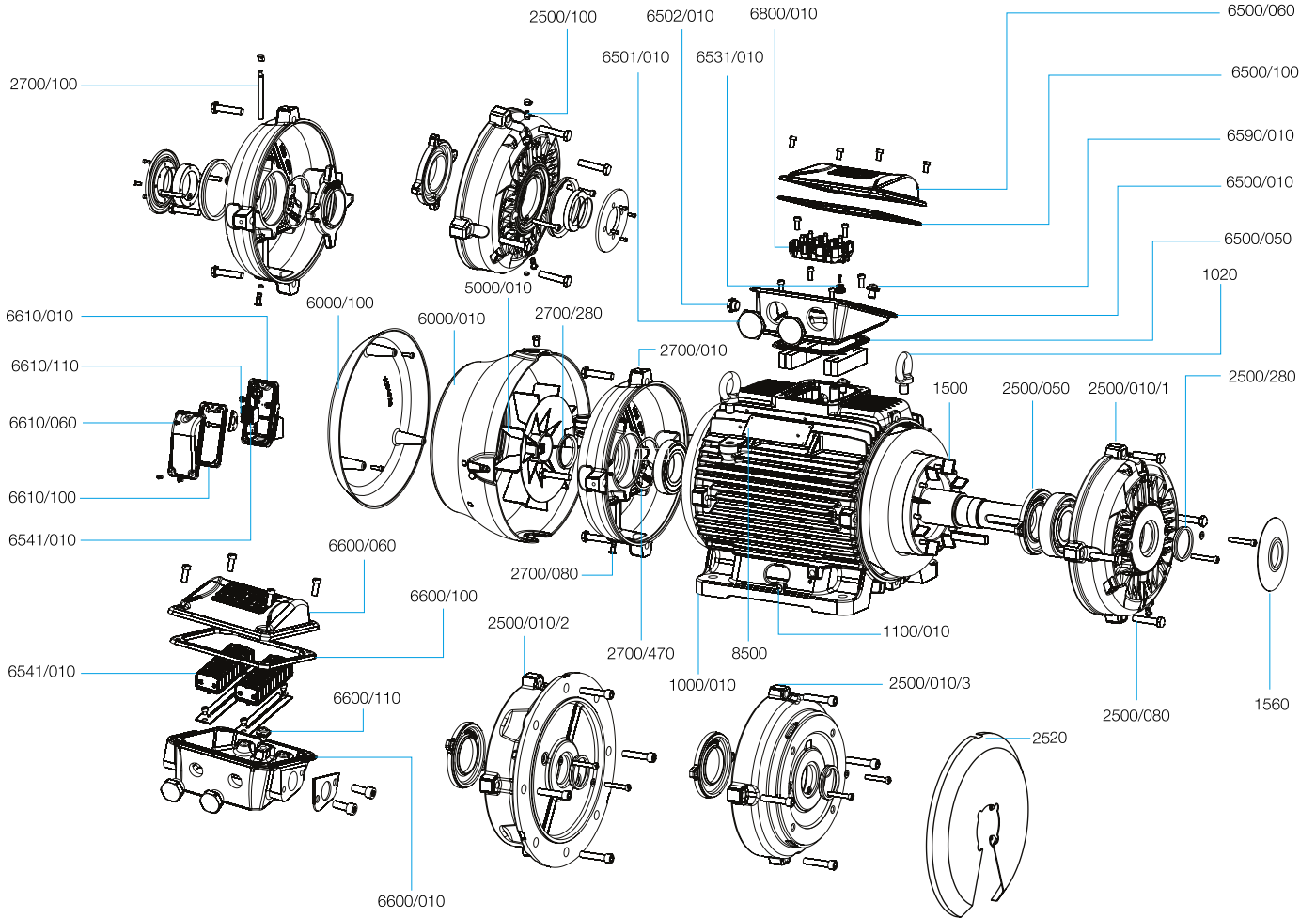

Motor component		Spare part	
Item	Description	Item	Composition
1000/010	Frame with wound stator		
1020	Lifting eyebolt	1020	Lifting eyebolt
1100/010	Earthing terminal		
1500	Rotor, complete with shaft and key		
1560	Slinger	1560	Slinger (recommended for vertical shaft up applications, non-flange mounted)
2500/010/1	Endshield, drive end	2500/1	Endshield, bearing cap, drain plug, shaft seal, bolts and washers
2500/050	Bearing cap, internal, drive end		
2500/080	Drain plug, drive end		
2500/280	Shaft seal, drive end (1)		
2500/100	Grease nipple, drive end (2)		
2500/010/2	D Flange	2500/2	D Flange, drain plug, shaft seal, bolts and washers
2500/080	Drain plug, drive end		
2500/100	Grease nipple, drive end (2)		
2500/280	Shaft seal, drive end (1)		
2500/010/3	C Flange (7)	2500/3	C Flange, drain plug, shaft seal, bolts and washers
2500/080	Drain plug, drive end		
2500/280	Shaft seal, drive end (1)		
2500/100	Grease nipple, drive end (2)		
2520	Air Deflector	2520	Air Deflector
2700/010	Endshield, non-drive end	2700	Endshield, drain plug, shaft seal, bolts and washers
2700/080	Drain plug, non-drive end		
2700/100	Grease nipple (with extensor pipe), non-drive end (4)		
2700/280	Shaft seal, non-drive end (1)		
2700/470	Wave washer for axial displacement (3)		
5000/010	Fan	5000	Fan (5)
6000/010	Fan cover (6)	6000	Fan cover, bolts
		6050	Fan cover, drip cover and bolts
6000/100	Drip cover	6100	Drip cover and bolts
6500/010	Terminal box	6500	Terminal box, complete with lid, gaskets (for lid and terminal box), plugs (for mains and accessories), earthing terminal, bolts and washers
6500/050	Terminal box gasket		
6500/060	Terminal box lid		
6500/100	Terminal box lid gasket		
6501/010	Terminal box plug for main leads		
6502/010	Terminal box plug for accessory leads		
6590/010	Terminal box earthing terminal		
6531/010	Accessory connector		
6541/010	Accessory connector	6541	Accessory connector, mounting rail, bolts and washers
6600/010	Accessory terminal box	6600	Accessory terminal box, complete with lid, gasket, plugs, earthing terminal, bolts and washers
6600/060	Accessory terminal box lid		
6600/100	Accessory terminal box lid gasket		
6600/110	Accessory terminal box earthing terminal		
6610/010	Space heater accessory terminal box	6610	Space heater accessory terminal box, complete with lid, gasket, plugs, earthing terminal, bolts and washers
6610/060	Space heater accessory terminal box lid		
6610/100	Space heater accessory terminal box lid gasket		
6610/110	Space heater accessory terminal box earthing terminal		
6800/010	Terminal block	6800	Terminal block, bolts and washers
8500	Main nameplate		

Notes:

- (1) The shaft seal may vary with product line. As a spare part, the shaft seal in the 254/6T - 324/6T range will be supplied as an integral part of the endshield kit. If fitted with labyrinth seal (taconite or W3 Seal®) internal bearing cap is mandatory from frame 254/6T.
- (2) When fitted with grease nipple, the endshield spare part kit will also have grease relief.
- (3) Valid when ball bearing is fitted in drive end. When the drive end is fitted with roller bearings, the wave washer is not supplied (non-drive end bearing locked-with internal bearing cap).
- (4) When fitted with grease nipple in the non-drive end, the endshield spare part kit will also have grease relief and internal bearing cap.
- (5) When non-plastic fan is fitted, the spare part kit is also supplied with key and circlip for fan assembly onto the shaft.
- (6) The fan cover material may vary with product line. Considering general purpose, it is cast iron in the 254/6T - 324/6T range and steel fabricated to 213/5T frame.
- (7) C flange dimensions according to NEMA MG-1 Part 4 standard.

General Information

The following information is required when purchasing of spare parts:

- Serial number and manufacturing date, both stamped in the nameplate
- Spare part description
- Codes shown are for reference only. Final codes of spare parts will depend on colour

Spare Parts Available 364/5T to 588/9T

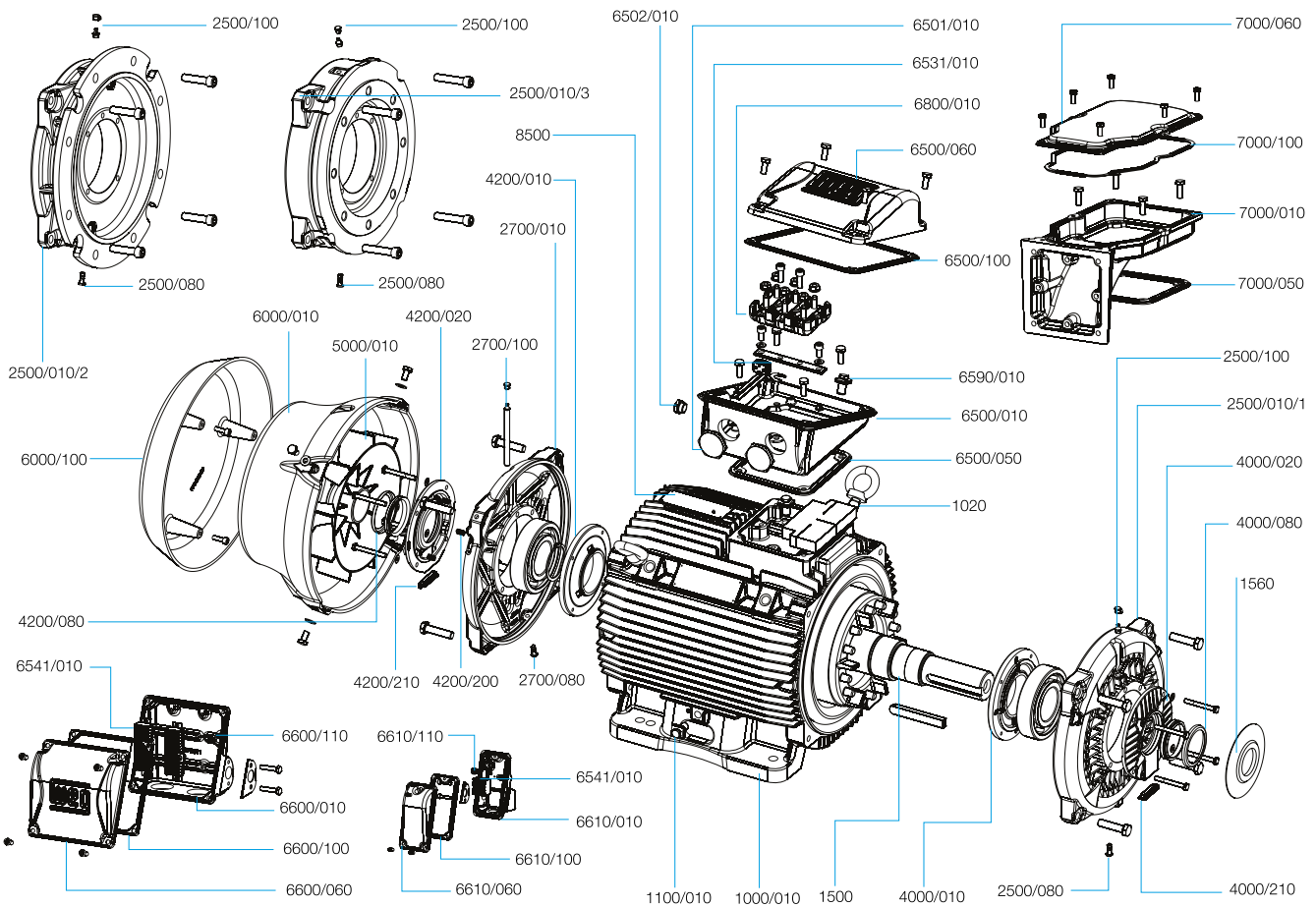

Motor component		Spare part	
Item	Description	Item	Composition
1000/010	Frame with wound stator		
1020	Lifting eyebolt	1020	Lifting eyebolt
1100/010	Earthing terminal		
1500	Rotor, complete with shaft and key		
1560	Slinger	1560	Slinger
2500/010/1	Endshield, drive end	2500/1	Endshield, grease nipple, drain plug, bolts and washers
2500/080	Drain plug, drive end		
2500/100	Grease nipple, drive end		
2500/010/2	D Flange	2500/2	D Flange, grease nipple, drain plug, bolts and washers
2500/080	Drain plug, drive end		
2500/100	Grease nipple, drive end		
2500/010/3	C Flange (5)	2500/3	C Flange, grease nipple, drain plug, bolts and washers
2500/080	Drain plug, drive end		
2500/100	Grease nipple, drive end		
2700/010	Endshield, non-drive end	2700	Endshield, grease nipple with extensor pipe, drain plug, bolts and washers
2700/080	Drain plug, non-drive end		
2700/100	Grease nipple (with extensor pipe), non-drive end		
4000/010	Bearing cap, internal, drive end	4000	Bearing cap (external and internal), shaft seal, grease relief, bolts and washers
4000/020	Bearing cap, external, drive end		
4000/080	Shaft seal, drive end (1)		
4000/210	Grease relief	4200	Bearing cap (external and internal), shaft seal, grease relief with extensor pipe, pre-load springs, bolts and washers
4200/010	Bearing cap, internal, non-drive end		
4200/020	Bearing cap, external, non-drive end		
4200/080	Shaft seal, non-drive end (1)		
4200/200	Pre-load springs for axial displacement (2)		
4200/210	Grease relief		
5000/010	Fan	5000	Fan (3)
6000/010	Fan cover, cast iron	6000	Fan cover, bolts
		6050	Fan cover, drip cover and bolts
6000/100	Drip cover	6100	Drip cover and bolts
6500/010	Terminal box	6500	Terminal box, complete with lid, gaskets (for lid and terminal box), plugs (for mains and accessories), earthing terminal, bolts and washers
6500/050	Terminal box gasket		
6500/060	Terminal box lid		
6500/100	Terminal box lid gasket		
6501/010	Terminal box plug for main leads		
6502/010	Terminal box plug for accessory leads		
6590/010	Terminal box earthing terminal		
6531/010	Accessory connector	6531	Accessory connector, mounting rail, bolts and washers
6541/010	Accessory connector	6541	Accessory connector, mounting rail, bolts and washers
6600/010	Accessory terminal box	6600	Accessory terminal box, complete with lid, gasket, plugs, earthing terminal, bolts and washers
6600/060	Accessory terminal box lid		
6600/100	Accessory terminal box lid gasket		
6600/110	Accessory terminal box earthing terminal		
6610/010	Space heater accessory terminal box	6610	Space heater accessory terminal box, complete with lid, gasket, plugs, earthing terminal, bolts and washers
6610/060	Space heater accessory terminal box lid		
6610/100	Space heater accessory terminal box lid gasket		
6610/110	Space heater accessory terminal box earthing terminal		
6800/010	Terminal block	6800	Terminal block, mounting rail, bolts and washers
7000/010	Terminal box adaptor base	7000	Terminal box adaptor for side mounted position, complete with lid, gaskets, bolts and washers
7000/050	Terminal box adaptor base gasket		
7000/060	Terminal box adaptor lid		
7000/100	Terminal box adaptor lid gasket		
8500	Main nameplate (4)		

Notes:

- (1) The shaft sealing may vary with product line. As a spare part, the shaft sealing in the 364/5T - 588/9T range will be supplied as an integral part of the bearing cap kit.
- (2) Valid when ball bearing is fitted in drive end. When the drive end is fitted with roller bearings, pre-load springs are not supplied (non-drive end bearing locked).
- (3) When non-plastic fan is fitted, the spare part kit is also supplied with key and circlip for fan assembly onto the shaft.
- (4) Main nameplate position will vary with terminal box configuration (top and side mounting)
- (5) C flange dimensions according to NEMA MG-1 Part 4 standard.

WEG Worldwide Operations

ARGENTINA

WEG EQUIPAMIENTOS
ELECTRICOS S.A.
(Headquarters San
Francisco-Cordoba)
Sgo. Pampiglione 4849
Parque Industrial San Francisco
2400 - San Francisco
Phone: +54 (3564) 421484
Fax: +54 (3564) 421459
info-ar@weg.net
www.weg.net/ar

WEG PINTURAS

Mélian, 2983
Parque Industrial Burzaco
Buenos Aires - Argentina
Phone: (54-11) 4299-8000
tintas@weg.net

AUSTRALIA

WEG AUSTRALIA PTY. LTD.
14 Lakeview Drive Caribbean
Gardens Industrial Estate
Scoresby Vic 3179 Victoria
Phone: 61 (3) 9765 4600
Fax: 61 (3) 9753 2088
info-au@weg.net
www.weg.net/au

BELGIUM

WEG BENELUX S.A.
Rue de l'Industrie 30 D,
1400 Nivelles
Phone: + 32 (67) 88-8420
Fax: + 32 (67) 84-1748
info-be@weg.net
www.weg.net/be

CHILE

WEG CHILE S.A.
Los Canteros 8600
La Reina - Santiago
Phone: (56-2) 784 8900
Fax: (56-2) 784 8950
info-cl@weg.net
www.weg.net/cl

CHINA

WEG (NANTONG) ELECTRIC
MOTOR MANUFACTURING CO.,
LTD.
No. 128# - Xinkai South Road,
Nantong Economic &
Technical Development Zone,
Nantong, Jiangsu Province.
Phone: (86) 0513-85989333
Fax: (86) 0513-85922161
info-cn@weg.net
www.weg.net/cn

COLOMBIA

WEG COLOMBIA LTDA
Calle 46A N82 - 54
Porteria II - Bodega 7 - San
Cayetano II - Bogotá
Phone: (57 1) 416 0166
Fax: (57 1) 416 2077
info-co@weg.net
www.weg.net/co

DENMARK

WEG SCANDINAVIA DENMARK
Sales Office of WEG
Scandinavia AB
Anelysparken 43B
True
8381 Tilst - Denmark
Phone: +45 86 24 22 00
Fax : +45 86 24 56 88
info-se@weg.net
www.weg.net/se

FRANCE

WEG FRANCE SAS
ZI de Chenes - Le Loup
13 Rue du Morellon - BP 738
38297 Saint Quentin Fallavier
Phone: +33 (0) 4 74 99 11 35
Fax: +33 (0) 4 74 99 11 44
info-fr@weg.net
www.weg.net/fr

GERMANY

WEG GERMANY GmbH
Industriegebiet Türnich 3
Geigerstraße 7
50169 Kerpen-Türnich
Phone: +49 (0)2237/9291-0
Fax: +49 (0)2237/9292-200
info-de@weg.net
www.weg.net/de

GHANA

ZEST ELECTRIC GHANA
LIMITED - WEG Group
15, Third Close Street Airport
Residential Area, Accra PMB CT
175, Cantonments
Phone: 233 30 27 664 90
Fax: 233 30 27 664 93
info@zestghana.com.gh
www.zestghana.com.gh

INDIA

WEG ELECTRIC (INDIA) PVT. LTD.
#38, Ground Floor, 1st Main
Road, Lower Palace Orchards,
Bangalore - 560 003
Phone(s): +91-80-4128 2007
+91-80-4128 2006
Fax: +91-80-2336 7624
info-in@weg.net
www.weg.net/in

WEG INDUSTRIES (INDIA) PVT.LTD

Plot E-20 (North)
SIPCOT industria complex,
Phase II
Expansion II, Mornapalli Village
Hosur 635 109
Tamil Nadu, INDIA
Phone: 04344-261501 / 261503
Fax: 04344-261516 / 261558
info-in@weg.net
www.weg.net/in

ITALY

WEG ITALIA S.R.L.
V.le Brianza 20 - 20092 - Cinisello
Balsamo - Milano
Phone: (39) 02 6129-3535
Fax: (39) 02 6601-3738
info-it@weg.net
www.weg.net/it

JAPAN

WEG ELECTRIC MOTORS
JAPAN CO., LTD.
Yokohama Sky Building 20F,
2-19-12 Takashima,
Nishi-ku, Yokohama City,
Kanagawa, Japan 220-001
Phone: (81) 45 440 6063
info-jp@weg.net
www.weg.net/jp

MEXICO

WEG MEXICO, S.A. DE C.V.
Carretera Jorobas-Tula Km. 3.5,
Manzana 5, Lote 1
Fraccionamiento Parque
Industrial - Huehuetoca,
Estado de México - C.P. 54680
Phone: + 52 (55) 5321 4275
Fax: + 52 (55) 5321 4262
info-mx@weg.net
www.weg.net/mx

NETHERLANDS

WEG NETHERLANDS
Sales Office of
WEG Benelux S.A.
Hanzepoort 23C
7575 DB Oldenzaal
Phone: +31 (0) 541-571080
Fax: +31 (0) 541-571090
info-nl@weg.net
www.weg.net/nl

PORTUGAL

WEG EURO - INDÚSTRIA
ELÉCTRICA, S.A.
Rua Eng. Frederico Ulrich
Apartado 6074
4476-908 - Maia
Phone: +351 229 477 705
Fax: +351 229 477 792
info-pt@weg.net
www.weg.net/pt

RUSSIA

WEG RUSSIA
Russia, 194292, St. Petersburg,
Prospekt Kultury 44, Office 419
Phone: +7(812)363-21-72
Fax: +7(812)363-21-73
info-ru@weg.net
www.weg.net/ru

SOUTH AFRICA

ZEST ELECTRIC MOTORS
(PTY) LTD. WEG Group
47 Galaxy Avenue, Linbro
Business Park, Gauteng
Private Bag X10011, Sandton,
2146 Johannesburg
Phone: (27-11) 723-6000
Fax: (27-11) 723-6001
info@zest.co.za
www.zest.co.za

SPAIN

WEG IBERIA S.L.
Avenida de la Industria, 25
28823 Coslada - Madrid
Phone: (34) 916 553 008
Fax : (34) 916 553 058
info-es@weg.net
www.weg.net/es

SINGAPORE

WEG SINGAPORE PTE LTD
159, Kampong Ampat,
#06-02A KA PLACE.
Singapore 368328.
Phone: +65 6858 9081
Fax: +65 6858 1081
info-sg@weg.net
www.weg.net/sg

SWEDEN

WEG SCANDINAVIA AB
Box 10196
Verkstadgatan 9
434 22 Kungsbacka
Phone: (46) 300 73400
Fax: (46) 300 70264
info-se@weg.net
www.weg.net/se

UK

WEG ELECTRIC
MOTORS (U.K.) LTD.
28/29 Walkers Road
Manorside Industrial Estate
North Moons Moat - Redditch
Worcestershire B98 9HE
Phone: 44 (0)1527 596-748
Fax: 44 (0)1527 591-133
info-uk@weg.net
www.weg.net/uk

UNITED ARAB EMIRATES

WEG MIDDLE EAST FZE
JAFZA - JEBEL ALI FREE ZONE
Tower 18, 19th Floor,
Office LB 18 1905
P.O. Box 262508 - Dubai
Phone: +971 (4) 8130800
Fax: +971 (4) 8130811
info-ae@weg.net
www.weg.net/ae

USA

WEG ELECTRIC CORP.
6655 Sugarloaf Parkway,
Duluth, GA 30097
Phone: 1-678-249-2000
Fax: 1-770-338-1632
info-us@weg.net
www.weg.net/us

VENEZUELA

WEG INDUSTRIAS VENEZUELA C.A.
Avenida 138-A
Edificio Torre Banco Occidental de
Descuento, Piso 6 Oficina 6-12
Urbanizacion San Jose de Tarbes
Zona Postal 2001
Valencia, Edo. Carabobo
Phone(s): (58) 241 8210582
(58) 241 8210799
(58) 241 8211457
Fax: (58) 241 8210966
info-ve@weg.net
www.weg.net/ve



WEG Equipamentos Elétricos S.A.
International Division
Av. Prefeito Waldemar Grubba, 3000
89256-900 - Jaraguá do Sul - SC - Brazil
Phone: 55 (47) 3276-4002
Fax: 55 (47) 3276-4060
www.weg.net

